

# Brocade Fabric OS Administration Guide, 8.0.1

Supporting Fabric OS 8.0.1

© 2016, Brocade Communications Systems, Inc. All Rights Reserved.

Brocade, Brocade Assurance, the B-wing symbol, ClearLink, DCX, Fabric OS, HyperEdge, ICX, MLX, MyBrocade, OpenScript, VCS, VDX, Vplane, and Vyatta are registered trademarks, and Fabric Vision is a trademark of Brocade Communications Systems, Inc., in the United States and/or in other countries. Other brands, products, or service names mentioned may be trademarks of others.

Notice: This document is for informational purposes only and does not set forth any warranty, expressed or implied, concerning any equipment, equipment feature, or service offered or to be offered by Brocade. Brocade reserves the right to make changes to this document at any time, without notice, and assumes no responsibility for its use. This informational document describes features that may not be currently available. Contact a Brocade sales office for information on feature and product availability. Export of technical data contained in this document may require an export license from the United States government.

The authors and Brocade Communications Systems, Inc. assume no liability or responsibility to any person or entity with respect to the accuracy of this document or any loss, cost, liability, or damages arising from the information contained herein or the computer programs that accompany it.

The product described by this document may contain open source software covered by the GNU General Public License or other open source license agreements. To find out which open source software is included in Brocade products, view the licensing terms applicable to the open source software, and obtain a copy of the programming source code, please visit <http://www.brocade.com/support/oscd>.

# Contents

---

<b>Preface</b> .....	<b>19</b>
Document conventions.....	19
Text formatting conventions.....	19
Command syntax conventions.....	19
Notes, cautions, and warnings.....	20
Brocade resources.....	20
Contacting Brocade Technical Support.....	20
Brocade customers.....	20
Brocade OEM customers.....	21
Document feedback.....	21
<b>About This Document</b> .....	<b>23</b>
Supported hardware and software.....	23
Brocade Gen 5 (16-Gbps) fixed-port Switches.....	23
Brocade Gen 5 (16-Gbps) DCX 8510 Directors.....	23
Brocade Gen 6 fixed-port Switches.....	23
Brocade Gen 6 Directors.....	24
What's new in this document for 8.0.1.....	24
<b>Understanding Fibre Channel Services</b> .....	<b>25</b>
Fibre Channel services overview.....	25
Management server.....	26
Platform services.....	26
Platform services and Virtual Fabrics.....	26
Enabling platform services.....	27
Disabling platform services .....	27
Management server database.....	27
Displaying the management server ACL.....	27
Adding a member to the ACL.....	28
Deleting a member from the ACL .....	29
Viewing the contents of the management server database .....	30
Clearing the management server database.....	30
Topology discovery.....	31
Displaying topology discovery status.....	31
Enabling topology discovery .....	31
Disabling topology discovery.....	31
Device login.....	32
Principal switch.....	32
E_Port login process .....	33
Fabric login process .....	33
Port login process.....	33
RSCNs.....	33
Duplicate Port World Wide Name.....	34
High availability of daemon processes.....	34
FL_Port and arbitrated loop support.....	35
<b>Performing Basic Configuration Tasks</b> .....	<b>37</b>
Fabric OS overview.....	37

Fabric OS command line interface.....	37
Console sessions using the serial port.....	38
Telnet or SSH sessions.....	38
Getting help on a command.....	40
Viewing a history of command line entries.....	41
Using foexec to run commands on remote switches or domains.....	43
Password modification.....	45
Default account passwords.....	46
The switch Ethernet interface .....	46
Brocade Directors.....	46
Brocade switches.....	47
Virtual Fabrics and the Ethernet interface.....	47
Management Ethernet port bonding.....	47
Displaying the network interface settings.....	48
Resetting the management network interface error counters.....	49
Static Ethernet addresses.....	49
DHCP activation.....	51
IPv6 autoconfiguration.....	55
Setting the Ethernet interface mode and speed.....	56
Date and time settings.....	56
Setting the date and time.....	57
Time zone settings.....	57
Network Time Protocol.....	59
Domain IDs.....	61
Domain ID issues.....	61
Displaying the domain IDs.....	62
Setting the domain ID.....	62
Switch names.....	63
Customizing the switch name.....	63
Chassis names.....	63
Customizing chassis names.....	63
Fabric name.....	64
Configuring the fabric name.....	64
High availability considerations for fabric names.....	64
Upgrade and downgrade considerations for fabric names.....	64
Switch activation and deactivation.....	64
Disabling a switch.....	65
Enabling a switch.....	65
Disabling a chassis.....	65
Enabling a chassis.....	66
Device shutdown.....	66
Powering off a Brocade switch.....	66
Powering off a Brocade Director.....	66
Basic connections.....	67
Device connection.....	67
Switch connection.....	67
<b>Performing Advanced Configuration Tasks.....</b>	<b>69</b>
Port identifiers (PIDs) and PID binding overview.....	69
Core PID addressing mode.....	69
Fixed addressing mode.....	70



10-bit addressing (mode 0).....	70
256-area addressing (mode 1 and mode 2).....	70
WWN-based PID assignment.....	71
Ports.....	73
Port Types.....	73
Director port blades.....	73
Setting port names.....	74
Port identification by slot and port number.....	75
Port identification by port area ID.....	75
Port identification by index.....	75
Dynamic Portname.....	75
Configuring a device-switch connection .....	81
Swapping port area IDs.....	81
Enabling a port.....	82
Disabling a port.....	82
Port decommissioning.....	83
Setting port speeds.....	83
Setting all ports on a switch to the same speed.....	84
Setting port speed for a port octet.....	84
Setting maximum auto-negotiated port speed.....	86
Decoding fdmiShow command output.....	86
Blade terminology and compatibility.....	87
CP blades.....	88
Core blades.....	89
Port and application blade compatibility.....	89
Enabling and disabling blades.....	89
Enabling blades.....	89
Disabling blades.....	90
Blade swapping.....	90
How blades are swapped.....	91
Swapping blades.....	94
Disabling switches.....	95
Power management.....	95
Powering off a port blade or core blade.....	95
Powering on a port blade or core blade.....	96
Equipment status.....	96
Checking switch operation.....	96
Verifying High Availability features (Backbones and Directors only).....	96
Verifying fabric connectivity.....	97
Verifying device connectivity.....	97
Audit log configuration.....	97
Verifying host syslog prior to configuring the audit log.....	98
Configuring an audit log for specific event classes.....	99
Configuring remote syslog servers.....	99
Hostname support for syslogAdmin command.....	100
Duplicate PWWN handling during device login.....	101
Setting 0, First login precedence.....	101
Setting 1, Second login precedence.....	101
Setting 2, Mixed precedence.....	102
Setting the behavior for handling duplicate PWWNs.....	102

Forward error correction.....	103
FEC limitations.....	103
Enabling forward error correction.....	103
Disabling forward error correction.....	104
Enabling or disabling FEC for long-distance ports .....	105
Displaying and clearing the FEC counters.....	105
FEC-via-TTS.....	105
<b>Routing Traffic.....</b>	<b>107</b>
Routing overview.....	107
Paths and route selection.....	107
FSPF.....	107
Fibre Channel NAT.....	109
Inter-switch links.....	109
Buffer credits.....	111
Congestion versus over-subscription.....	111
Virtual channels.....	111
Gateway links.....	112
Configuring a link through a gateway.....	113
Routing policies.....	114
Notes .....	114
Displaying the current routing policy.....	114
Port-based routing .....	114
Exchange-based routing.....	115
Device-based routing.....	115
Dynamic Path Selection.....	115
Route selection.....	116
Dynamic Load Sharing.....	116
Frame order delivery.....	117
Forcing in-order frame delivery across topology changes.....	118
Restoring out-of-order frame delivery across topology changes.....	118
Enabling Frame Viewer.....	118
Using Frame Viewer to understand why frames are dropped .....	119
Lossless Dynamic Load Sharing on ports.....	120
Lossless core.....	121
Configuring Lossless Dynamic Load Sharing .....	121
Lossless Dynamic Load Sharing in Virtual Fabrics.....	122
Two-hop Lossless DLS route update.....	122
Frame Redirection.....	123
Creating a frame redirect zone.....	124
Deleting a frame redirect zone.....	125
Viewing frame redirect zones.....	125
<b>Buffer-to-Buffer Credits and Credit Recovery.....</b>	<b>127</b>
Buffer credit management .....	127
Buffer-to-buffer flow control.....	127
Optimal buffer credit allocation .....	128
Fibre Channel gigabit values reference definition.....	128
Buffer credit allocation based on full-size frames.....	129
Allocating buffer credits based on average-size frames.....	131
Configuring buffers for a single port directly.....	132

Configuring buffers using frame size.....	132
Calculating the number of buffers required given the distance, speed, and frame size.....	132
Allocating buffer credits for F_Ports.....	133
Monitoring buffers in a port group.....	134
Buffer credits per switch or blade model.....	135
Maximum configurable distances for Extended Fabrics.....	136
Downgrade considerations.....	137
Configuring credits for a single VC.....	138
Buffer credit recovery .....	139
Buffer credit recovery over an E_Port.....	139
Buffer credit recovery over an F_Port.....	139
Buffer credit recovery over an EX_Port.....	140
Enabling and disabling buffer credit recovery.....	140
Credit loss detection.....	141
Back-end credit loss detection and recovery support on Brocade 6520 switches.....	141
Enabling back-end credit loss detection and recovery for link reset thresholds.....	141
Performing link reset for loss of sync from peer ports.....	142
Back-end credit loss detection and recovery for link faults.....	143
<b>Managing User Accounts.....</b>	<b>145</b>
User accounts overview .....	145
Role-Based Access Control.....	145
Management channel.....	147
Managing user-defined roles.....	147
Configuring time-based access.....	148
Local database user accounts.....	149
Default accounts.....	149
Local account passwords.....	151
Local user account database distribution.....	151
Distributing the local user database.....	151
Accepting distributed user databases on the local switch.....	152
Rejecting distributed user databases on the local switch.....	152
Password policies.....	152
Password strength policy.....	152
Password history policy.....	153
Password expiration policy.....	154
Account lockout policy.....	155
Changing the root password without the old password.....	156
Configuring the password hash type.....	156
The boot PROM password.....	157
Setting the boot PROM password for a switch with a recovery string.....	157
Setting the boot PROM password for a Backbones and Directors with a recovery string.....	158
Setting the boot PROM password for a switch without a recovery string.....	159
Setting the boot PROM password for a Backbone or Director without a recovery string.....	159
Remote authentication.....	160
Remote authentication configuration.....	160
Setting the switch authentication mode.....	163
Fabric OS user accounts.....	163
Fabric OS users on the RADIUS server.....	164
Setting up a RADIUS server.....	166
LDAP configuration and Microsoft Active Directory.....	174

LDAP configuration and OpenLDAP.....	176
TACACS+ service.....	180
Remote authentication configuration on the switch.....	182
Configuring local authentication as backup.....	184
<b>Configuring Protocols.....</b>	<b>185</b>
Security protocols.....	185
Secure Copy.....	186
Setting up SCP for configuration uploads and downloads.....	187
Secure Shell protocol.....	187
SSH public key authentication.....	187
Managing SecCryptoCfg templates.....	190
Configuring the ciphers, KEX, and MAC algorithms.....	194
Secure Sockets Layer protocol .....	195
Browser and Java support.....	195
SSL configuration overview.....	195
The browser .....	199
Root certificates for the Java plugin.....	200
Simple Network Management Protocol.....	200
SNMP Manager.....	201
SNMP Agent.....	201
Management Information Base.....	201
Basic SNMP operation.....	201
Configuring SNMP using CLI.....	202
Telnet protocol.....	211
Blocking Telnet.....	211
Unblocking Telnet.....	212
Listener applications.....	213
Ports and applications used by switches.....	213
Port configuration.....	214
<b>Configuring Security Policies.....</b>	<b>215</b>
ACL policies overview.....	215
How the ACL policies are stored.....	215
Policy members.....	216
ACL policy management.....	216
Displaying ACL policies.....	216
Saving changes without activating the policies.....	216
Activating ACL policy changes.....	217
Deleting an ACL policy.....	217
Adding a member to an existing ACL policy.....	217
Removing a member from an ACL policy.....	218
Abandoning unsaved ACL policy changes.....	218
FCS policies.....	218
FCS policy restrictions.....	219
Ensuring fabric domains share policies .....	220
Creating an FCS policy.....	220
Modifying the order of FCS switches.....	220
FCS policy distribution.....	221
Device Connection Control policies.....	222
<b>Virtual Fabrics considerations</b> .....	<b>222</b>

DCC policy restrictions.....	222
Creating a DCC policy.....	223
Deleting a DCC policy.....	224
DCC policy behavior with Fabric-Assigned PWWNs.....	224
SCC Policies.....	226
<b>Virtual Fabrics considerations for SCC policies</b> .....	226
Creating an SCC policy.....	226
Authentication policy for fabric elements.....	227
<b>Virtual Fabrics considerations</b> .....	228
E_Port authentication.....	228
Device authentication policy.....	230
AUTH policy restrictions.....	230
Authentication protocols.....	231
Secret key pairs for DH-CHAP.....	232
FCAP configuration overview.....	233
Fabric-wide distribution of the authorization policy.....	236
IP Filter policy.....	236
<b>Virtual Fabrics considerations for IP Filter policy</b> .....	236
Creating an IP Filter policy.....	236
Cloning an IP Filter policy.....	236
Displaying an IP Filter policy.....	237
Saving an IP Filter policy.....	237
Activating an IP Filter policy.....	237
Deleting an IP Filter policy.....	237
IP Filter policy rules.....	238
IP Filter policy enforcement.....	240
Adding a rule to an IP Filter policy.....	241
Deleting a rule from an IP Filter policy.....	241
Aborting an IP Filter transaction.....	241
IP Filter policy distribution.....	241
Policy database distribution.....	242
Database distribution settings.....	243
ACL policy distribution to other switches.....	244
Fabric-wide enforcement.....	244
Notes on joining a switch to the fabric.....	245
Management interface security.....	247
Configuration examples.....	248
IPsec protocols.....	249
Security associations.....	250
Authentication and encryption algorithms.....	250
IPsec policies.....	251
IKE policies.....	251
Creating the tunnel.....	252
Example of an end-to-end transport tunnel mode.....	254
<b>Maintaining the Switch Configuration File.....</b>	<b>257</b>
Configuration settings.....	257
Configuration file format .....	258
Configuration file backup.....	259
Considerations for FTP server credentials with special characters.....	259
Uploading a configuration file in interactive mode.....	261

Configuration file restoration.....	261
Restrictions.....	261
Configuration download without disabling a switch.....	263
Configurations across a fabric.....	264
Downloading a configuration file from one switch to another switch of the same model.....	264
Security considerations.....	264
Configuration management for Virtual Fabrics.....	264
Uploading a configuration file from a switch with Virtual Fabrics enabled.....	264
Restoring a logical switch configuration using configDownload.....	265
Restrictions.....	266
Brocade configuration form.....	266
<b>Managing Virtual Fabrics.....</b>	<b>267</b>
Virtual Fabrics overview.....	267
Logical switch overview.....	268
Default logical switch.....	268
Logical switches and fabric IDs.....	269
Port assignment in logical switches.....	270
Logical switches and connected devices.....	272
Management model for logical switches.....	273
Logical fabric overview.....	274
Logical fabric and ISLs.....	274
Base switch and extended ISLs.....	275
Account management and Virtual Fabrics.....	279
Setting up IP addresses for a logical switch.....	279
Logical switch login context.....	280
Supported platforms for Virtual Fabrics.....	281
Supported port configurations in the fixed-port switches.....	281
Supported port configurations in Brocade Backbones and Directors.....	282
Virtual Fabrics interaction with other Fabric OS features.....	282
Limitations and restrictions of Virtual Fabrics.....	283
Restrictions on XISLs.....	284
Restrictions on moving ports.....	284
Enabling Virtual Fabrics mode.....	284
Disabling Virtual Fabrics mode.....	285
Configuring logical switches to use basic configuration values.....	286
Creating a logical switch or base switch.....	286
Executing a command in a different logical switch context.....	288
Deleting a logical switch.....	288
Adding and moving ports on a logical switch.....	289
Displaying logical switch configuration.....	290
Changing the fabric ID of a logical switch.....	290
Changing a logical switch to a base switch.....	291
Configuring a logical switch for XISL use.....	292
Changing the context to a different logical fabric.....	293
Creating a logical fabric using XISLs.....	293
<b>Administering Advanced Zoning.....</b>	<b>297</b>
Zone types.....	297
Zoning overview.....	298
Approaches to zoning.....	299

Zone objects.....	300
Zone configurations.....	301
Zoning enforcement.....	301
Considerations for zoning architecture.....	302
Best practices for zoning.....	302
Broadcast zones.....	303
Broadcast zones and FC-FC routing.....	304
High availability considerations with broadcast zones.....	304
Loop devices and broadcast zones.....	304
Broadcast zones and default zoning mode.....	304
Zone aliases.....	304
Creating an alias.....	305
Adding members to an alias.....	305
Removing members from an alias.....	306
Deleting an alias.....	306
Viewing an alias in the defined configuration.....	307
Zone creation and maintenance.....	307
Displaying existing zones .....	307
Creating a zone.....	308
Adding devices (members) to a zone.....	309
Removing devices (members) from a zone.....	310
Replacing zone members.....	311
Deleting a zone.....	312
Viewing a zone.....	313
Viewing zone configuration names without case distinction.....	314
Validating a zone.....	315
Default zoning mode.....	318
Setting the default zoning mode.....	319
Viewing the current default zone access mode.....	319
Zone database size.....	320
Zone configurations.....	320
Creating a zone configuration.....	321
Adding zones to a zone configuration.....	321
Removing members from a zone configuration.....	322
Enabling a zone configuration.....	322
Disabling a zone configuration.....	322
Validating zone members in the zone configuration.....	323
Deleting a zone configuration.....	325
Abandoning zone configuration changes.....	326
Viewing all zone configuration information.....	326
Viewing selected zone configuration information.....	326
Viewing the zone aliases in the zone configuration.....	327
Viewing the configuration in the effective zone database.....	328
Clearing all zone configurations.....	328
Zone object maintenance.....	329
Copying a zone object.....	329
Deleting a zone object.....	330
Renaming a zone object.....	330
Zone configuration management.....	331
Security and zoning.....	331

Zone merging.....	332
Fabric segmentation and zoning.....	333
Zone merging scenarios.....	333
Concurrent zone transactions.....	339
Viewing zone database transactions.....	340
Peer Zoning.....	340
Peer Zoning compared to other zoning types.....	341
Advantages of Peer Zoning.....	344
Peer Zone connectivity rules.....	344
Firmware upgrade and downgrade considerations for Peer Zoning.....	345
LSAN and QoS Peer Zoning considerations.....	345
Peer Zone configuration.....	345
Target Driven Zoning.....	347
Limitations and considerations for Target Driven Zoning.....	348
Target Driven Zoning configuration.....	348
Supported commands for Peer Zones and Target Driven Peer Zones.....	351
Boot LUN zoning.....	352
Setting up boot LUN zoning.....	354
<b>Traffic Isolation Zoning.....</b>	<b>357</b>
Traffic Isolation Zoning overview.....	357
TI zone failover .....	358
FSPF routing rules and traffic isolation.....	359
Enhanced TI zones.....	361
Invalid configurations with enhanced TI zones.....	362
General rules for TI zones.....	364
Additional configuration rules for enhanced TI zones.....	365
Limitations and restrictions of Traffic Isolation Zoning.....	366
Creating a TI zone.....	366
Modifying TI zones.....	367
Changing the state of a TI zone.....	368
Deleting a TI zone.....	368
Displaying TI zones.....	368
Enforcing Local TI Filtering.....	369
Traffic Isolation Zoning over FC routers.....	370
TI zones within an edge fabric.....	371
TI zones within a backbone fabric.....	372
Limitations of TI zones over FC routers.....	373
Fabric-Level Traffic Isolation in a backbone fabric.....	374
Fabric-Level TI zones.....	375
Failover behavior for Fabric-Level TI zones.....	376
Creating a separate TI zone for each path.....	376
Creating a single TI zone for all paths.....	377
Setting up TI zones over FCR (sample procedure).....	378
Virtual Fabrics considerations for Traffic Isolation Zoning.....	381
Traffic Isolation Zoning over FC routers with Virtual Fabrics.....	383
Troubleshooting TI zone routing problems.....	385
Traffic Isolation Zone violation handling for trunk ports.....	386
<b>Optimizing Fabric Behavior.....</b>	<b>387</b>
Adaptive Networking overview.....	387



Ingress Rate Limiting.....	387
Virtual Fabrics considerations.....	388
Limiting traffic from a particular device.....	388
Disabling Ingress Rate Limiting.....	388
QoS.....	388
License requirements for QoS.....	389
QoS on E_Ports.....	389
QoS over FC routers.....	390
vTap and QoS High Priority Zoning Compatibility mode.....	391
Virtual Fabrics considerations for QoS zone-based traffic prioritization.....	392
Traffic prioritization based on QoS zones.....	393
CS_CTL-based frame prioritization.....	398
Supported configurations for CS_CTL-based frame prioritization.....	398
High availability considerations for CS_CTL-based frame prioritization.....	399
Enabling CS_CTL-based frame prioritization on ports.....	399
Disabling CS_CTL-based frame prioritization on ports.....	399
Using CS_CTL auto mode at the chassis level.....	399
Considerations for using CS_CTL-based frame prioritization.....	400
<b>In-flight Encryption and Compression.....</b>	<b>401</b>
In-flight encryption and compression overview.....	401
Supported ports for in-flight encryption and compression.....	402
In-flight encryption and compression restrictions.....	403
How in-flight encryption and compression are enabled.....	404
Authentication and key generation for encryption and compression.....	405
Availability considerations for encryption and compression.....	406
Virtual Fabrics considerations for encryption and compression.....	406
In-flight compression on long-distance ports.....	407
Compression ratios for compression-enabled ports.....	407
Configuring in-flight encryption and compression on an EX_Port.....	407
Configuring in-flight encryption and compression on an E_Port.....	408
Viewing the encryption and compression configuration.....	409
Configuring and enabling authentication for in-flight encryption.....	409
Enabling in-flight encryption.....	412
Enabling in-flight compression.....	412
Disabling in-flight encryption.....	413
Disabling in-flight compression.....	414
<b>Diagnostic Port.....</b>	<b>415</b>
Supported platforms for D_Port.....	415
Licensing requirements for D_Port.....	416
Understanding D_Port.....	416
D_Port configuration modes and testing.....	417
General limitations and considerations for D_Port tests.....	419
Topology 1: ISLs.....	421
Topology 2: ICLs.....	422
Topology 3: Access Gateways.....	422
Saving port mappings on an Access Gateway.....	424
Topology 4: HBA to switch.....	424
Using D_Port in static-static mode between switches.....	425
Enabling D_Port in static mode.....	425

Disabling D_Port in static mode.....	427
Disabling D_Port globally.....	427
Using D_Port in dynamic mode.....	427
Preprovisioning D_Ports.....	427
Using D_Port between switches and HBAs.....	429
Enabling D_Port in static mode between a switch and an HBA.....	429
Using non-Brocade HBAs for D_Port testing.....	429
BCU D_Port commands.....	430
Host Bus Adapter limitations and considerations for D_Ports.....	431
Confirming SFP and link status with an HBA.....	432
Using D_Port in on-demand mode .....	433
Using D_Port show commands.....	433
<b>NPIV.....</b>	<b>437</b>
NPIV overview.....	437
Upgrade considerations.....	438
Fixed addressing mode.....	438
10-bit addressing mode.....	438
Configuring NPIV.....	438
Enabling and disabling NPIV.....	439
Base device logout.....	440
Difference in the device logout behaviors.....	440
Enabling base device logout.....	441
Use cases and dependencies.....	441
Viewing base device logout setting.....	442
Viewing NPIV port configuration information.....	443
Viewing virtual PID login information.....	444
<b>Fabric-Assigned PWWN.....</b>	<b>445</b>
Fabric-Assigned PWWN overview.....	445
User- and auto-assigned FA-PWWN behavior .....	446
Configuring an FA-PWWN for an HBA connected to an Access Gateway.....	447
Configuring an FA-PWWN for an HBA connected to an edge switch.....	447
Supported switches and configurations for FA-PWWN.....	448
Configuration upload and download considerations for FA-PWWN.....	449
Security considerations for FA-PWWN.....	449
Restrictions of FA-PWWN.....	449
Access Gateway N_Port failover with FA-PWWN.....	450
<b>Inter-chassis Links.....</b>	<b>451</b>
Inter-chassis links .....	451
License requirements for ICLs.....	451
Using the QSFPs that support 2 km on ICL ports .....	452
ICLs between DCX 8510 Backbones.....	452
ICL trunking between Brocade DCX 8510 Backbones.....	454
ICLs between X6 Directors.....	455
ICL trunking between Brocade X6 Directors.....	458
ICLs between DCX 8510 Backbones and X6 Directors.....	459
ICL trunking between DCX 8510 Backbones and X6 Directors.....	461
Virtual Fabrics considerations for ICLs.....	462
Supported topologies for ICL connections.....	463
Mesh topology.....	463

Core-edge topology.....	465
<b>Managing Trunking Connections.....</b>	<b>467</b>
Trunking overview.....	467
Types of trunking.....	467
Masterless trunking.....	468
License requirements for trunking.....	468
Port groups for trunking.....	468
Supported platforms for trunking.....	469
Supported configurations for trunking.....	469
High Availability support for trunking.....	469
Requirements for trunk groups.....	469
Recommendations for trunk groups.....	470
Configuring trunk groups.....	471
Enabling trunking.....	471
Disabling trunking.....	471
Displaying trunking information.....	472
ISL trunking over long-distance fabrics.....	473
EX_Port trunking.....	474
Masterless EX_Port trunking.....	474
Supported configurations and platforms for EX_Port trunking.....	474
Configuring EX_Port trunking.....	475
Displaying EX_Port trunking information.....	475
F_Port trunking.....	475
F_Port trunking for Access Gateway.....	476
F_Port trunking for Brocade adapters.....	478
F_Port trunking considerations.....	479
F_Port trunking in Virtual Fabrics.....	480
Displaying F_Port trunking information.....	481
Disabling F_Port trunking.....	481
Enabling the DCC policy on a trunk area.....	482
<b>Managing Long-Distance Fabrics.....</b>	<b>483</b>
Long-distance fabrics overview.....	483
Extended Fabrics device limitations.....	483
Long-distance link modes.....	484
Configuring an extended ISL.....	484
Enabling long distance when connecting to TDM devices.....	486
Forward error correction on long-distance links.....	486
Enabling FEC on a long-distance link.....	486
Disabling FEC on a long-distance link.....	486
<b>Using FC-FC Routing to Connect Fabrics.....</b>	<b>489</b>
FC-FC routing overview.....	489
License requirements for FC-FC routing.....	489
Supported platforms for FC-FC routing.....	490
Supported configurations for FC-FC routing.....	491
Network OS connectivity limitations.....	491
Fibre Channel routing concepts.....	491
Proxy devices.....	496
FC-FC routing topologies.....	497
Phantom domains.....	497

FC router authentication .....	502
Setting up FC-FC routing.....	503
Verifying the setup for FC-FC routing.....	503
Backbone fabric IDs.....	504
Assigning backbone fabric IDs.....	505
Assigning alias names to fabric IDs.....	505
FCIP tunnel configuration.....	506
Inter-fabric link configuration.....	506
Configuring an IFL for both edge and backbone connections.....	506
Configuring EX_Ports on an ICL.....	510
FC router port cost configuration.....	511
Port cost considerations.....	512
Setting router port cost for an EX_Port.....	512
Shortest IFL cost configuration.....	513
Configuring shortest IFL cost.....	517
EX_Port frame trunking configuration.....	518
LSAN zone configuration.....	519
Zone definition and naming.....	519
LSAN zones and fabric-to-fabric communications.....	519
Controlling device communication with the LSAN.....	520
Configuring interconnectivity between backbone and edge fabrics.....	522
Setting the maximum LSAN count.....	522
HA and downgrade considerations for LSAN zones.....	523
LSAN zone policies using LSAN tagging.....	523
LSAN zone binding.....	528
Location embedded LSAN zones.....	532
Creating location embedded LSAN zones.....	533
Migrating LSAN zones to location embedded LSAN zones in the edge fabric.....	535
Limitations of location embedded LSAN zones.....	535
Peer LSAN zone support.....	536
Proxy PID configuration.....	536
Fabric parameter considerations.....	537
Inter-fabric broadcast frames.....	537
Displaying the current broadcast configuration.....	537
Enabling broadcast frame forwarding.....	537
Disabling broadcast frame forwarding.....	538
Resource monitoring.....	538
FC-FC routing and Virtual Fabrics.....	539
Logical switch configuration for FC routing.....	540
Backbone-to-edge routing with Virtual Fabrics.....	541
Upgrade and downgrade considerations for FC-FC routing.....	542
How replacing port blades affects EX_Port configuration.....	542
Displaying the range of output ports connected to xlate domains.....	543
<b>Port Indexing.....</b>	<b>545</b>
<b>Switch and blade sensors.....</b>	<b>547</b>
Brocade switch sensors.....	547
Brocade blade temperature sensors.....	547
System temperature monitoring.....	548
<b>Hexadecimal Conversion.....</b>	<b>549</b>

Hexadecimal overview.....	549
Example conversion of the hexadecimal triplet 0x616000.....	549
Decimal-to-hexadecimal conversion table.....	549



# Preface

---

- Document conventions..... 19
- Brocade resources..... 20
- Contacting Brocade Technical Support..... 20
- Document feedback..... 21

## Document conventions

The document conventions describe text formatting conventions, command syntax conventions, and important notice formats used in Brocade technical documentation.

## Text formatting conventions

Text formatting conventions such as boldface, italic, or Courier font may be used in the flow of the text to highlight specific words or phrases.

Format	Description
<b>bold text</b>	Identifies command names Identifies keywords and operands Identifies the names of user-manipulated GUI elements
<i>italic text</i>	Identifies text to enter at the GUI Identifies emphasis Identifies variables
Courier font	Identifies document titles Identifies CLI output Identifies command syntax examples

## Command syntax conventions

Bold and italic text identify command syntax components. Delimiters and operators define groupings of parameters and their logical relationships.

Convention	Description
<b>bold text</b>	Identifies command names, keywords, and command options.
<i>italic text</i>	Identifies a variable.
value	In Fibre Channel products, a fixed value provided as input to a command option is printed in plain text, for example, <b>--show</b> WWN.
[ ]	Syntax components displayed within square brackets are optional.
{ x   y   z }	Default responses to system prompts are enclosed in square brackets. A choice of required parameters is enclosed in curly brackets separated by vertical bars. You must select one of the options.
x   y	In Fibre Channel products, square brackets may be used instead for this purpose. A vertical bar separates mutually exclusive elements.
< >	Nonprinting characters, for example, passwords, are enclosed in angle brackets.

Convention	Description
...	Repeat the previous element, for example, <i>member{member...}</i> .
\	Indicates a "soft" line break in command examples. If a backslash separates two lines of a command input, enter the entire command at the prompt without the backslash.

## Notes, cautions, and warnings

Notes, cautions, and warning statements may be used in this document. They are listed in the order of increasing severity of potential hazards.

### NOTE

A Note provides a tip, guidance, or advice, emphasizes important information, or provides a reference to related information.

### ATTENTION

An Attention statement indicates a stronger note, for example, to alert you when traffic might be interrupted or the device might reboot.



### CAUTION

A Caution statement alerts you to situations that can be potentially hazardous to you or cause damage to hardware, firmware, software, or data.



### DANGER

*A Danger statement indicates conditions or situations that can be potentially lethal or extremely hazardous to you. Safety labels are also attached directly to products to warn of these conditions or situations.*

## Brocade resources

Visit the Brocade website to locate related documentation for your product and additional Brocade resources.

You can download additional publications supporting your product at [www.brocade.com](http://www.brocade.com). Select the Brocade Products tab to locate your product, then click the Brocade product name or image to open the individual product page. The user manuals are available in the resources module at the bottom of the page under the Documentation category.

To get up-to-the-minute information on Brocade products and resources, go to [MyBrocade](http://MyBrocade). You can register at no cost to obtain a user ID and password.

Release notes are available on [MyBrocade](http://MyBrocade) under Product Downloads.

White papers, online demonstrations, and data sheets are available through the [Brocade website](http://Brocade website).

## Contacting Brocade Technical Support

As a Brocade customer, you can contact Brocade Technical Support 24x7 online, by telephone, or by e-mail. Brocade OEM customers contact their OEM/Solutions provider.

## Brocade customers

For product support information and the latest information on contacting the Technical Assistance Center, go to <http://www.brocade.com/services-support/index.html>.

If you have purchased Brocade product support directly from Brocade, use one of the following methods to contact the Brocade Technical Assistance Center 24x7.



Online	Telephone	E-mail
<p>Preferred method of contact for non-urgent issues:</p> <ul style="list-style-type: none"> <li>• <a href="#">My Cases</a> through MyBrocade</li> <li>• <a href="#">Software downloads</a> and licensing tools</li> <li>• <a href="#">Knowledge Base</a></li> </ul>	<p>Required for Sev 1-Critical and Sev 2-High issues:</p> <ul style="list-style-type: none"> <li>• Continental US: 1-800-752-8061</li> <li>• Europe, Middle East, Africa, and Asia Pacific: +800-AT FIBREE (+800 28 34 27 33)</li> <li>• For areas unable to access toll free number: +1-408-333-6061</li> <li>• <a href="#">Toll-free numbers</a> are available in many countries.</li> </ul>	<p><a href="mailto:support@brocade.com">support@brocade.com</a></p> <p>Please include:</p> <ul style="list-style-type: none"> <li>• Problem summary</li> <li>• Serial number</li> <li>• Installation details</li> <li>• Environment description</li> </ul>

## Brocade OEM customers

If you have purchased Brocade product support from a Brocade OEM/Solution Provider, contact your OEM/Solution Provider for all of your product support needs.

- OEM/Solution Providers are trained and certified by Brocade to support Brocade® products.
- Brocade provides backline support for issues that cannot be resolved by the OEM/Solution Provider.
- Brocade Supplemental Support augments your existing OEM support contract, providing direct access to Brocade expertise. For more information, contact Brocade or your OEM.
- For questions regarding service levels and response times, contact your OEM/Solution Provider.

## Document feedback

To send feedback and report errors in the documentation you can use the feedback form posted with the document or you can e-mail the documentation team.

Quality is our first concern at Brocade and we have made every effort to ensure the accuracy and completeness of this document. However, if you find an error or an omission, or you think that a topic needs further development, we want to hear from you. You can provide feedback in two ways:

- Through the online feedback form in the HTML documents posted on [www.brocade.com](http://www.brocade.com).
- By sending your feedback to [documentation@brocade.com](mailto:documentation@brocade.com).

Provide the publication title, part number, and as much detail as possible, including the topic heading and page number if applicable, as well as your suggestions for improvement.



# About This Document

---

- [Supported hardware and software](#)..... 23
- [What's new in this document for 8.0.1](#)..... 24

## Supported hardware and software

The following hardware platforms are supported by Fabric OS 8.0.1.

### NOTE

Although many different software and hardware configurations are tested and supported by Brocade for Fabric OS 8.0.1, documenting all possible configurations and scenarios is beyond the scope of this document.

## Brocade Gen 5 (16-Gbps) fixed-port Switches

- Brocade 6505 Switch
- Brocade 6510 Switch
- Brocade 6520 Switch
- Brocade M6505 blade server SAN I/O module
- Brocade 6542 blade server SAN I/O module
- Brocade 6543 blade server SAN I/O module
- Brocade 6545 blade server SAN I/O module
- Brocade 6546 blade server SAN I/O module
- Brocade 6547 blade server SAN I/O module
- Brocade 6548 blade server SAN I/O module
- Brocade 6549 blade server SAN I/O module
- Brocade 6558 blade server SAN I/O module
- Brocade 6559 blade server SAN I/O module
- Brocade 7840 Extension Switch

## Brocade Gen 5 (16-Gbps) DCX 8510 Directors

### NOTE

For ease of reference, Brocade chassis-based storage systems are standardizing on the term "Director". The legacy term "Backbone" can be used interchangeably with the term "Director".

- Brocade DCX 8510-4 Director
- Brocade DCX 8510-8 Director

## Brocade Gen 6 fixed-port Switches

- Brocade G620 Switch

## Brocade Gen 6 Directors

- Brocade X6-4 Director
- Brocade X6-8 Director

Fabric OS support for the Brocade Analytics Monitoring Platform (AMP) device depends on the specific version of the software running on that platform. For more information, refer to the Brocade Analytics Monitoring Platform documentation and release notes.

## What's new in this document for 8.0.1

The following changes are applied to this document.

- Port Mirror feature is deprecated.
- FL\_Port and arbitrated loop support is deprecated.
- The "factory" user account is deprecated.
- References to X6 Directors are added along with DCX 8510 Backbones calling them "Directors" and/or "Backbones" respectively.
- References to 32 Gbps port speed, X6 Director blades, and Gen 6 functionality is added throughout the document wherever applicable.
- The Administrative Domains feature is deprecated. A warning message is displayed and a RASLog entry is generated for any AD configuration commands or if an AD is activated through a command or zone merge.
- The user password policies are updated.
- Switch names can start with a number.
- The "Dynamic port name format" topic is newly added to populate the port names in a predefined format.
- The "Setting port speed for a port octet" topic is updated to support Gen 6 port octet modes.
- The "Forward error correction" section is updated.
- The "Lossless Dynamic Load Sharing" section is updated.
- Buffer credits for Gen 6 devices and blades is added.
- The User Accounts chapter is updated.
  - The "Configuring time-based access" topic is newly added.
  - The default accounts and root access policies are modified.
  - The password strength policy supports "CharSet" and "AllowUsername" options.
  - The "Configuring the password hash type" topic is newly added.
  - The "Configuring RADIUS server support with Windows 2012" topic is updated.
- The "Managing SecCryptoCfg templates" and the "Default secCryptoCfg templates" topics are newly added.
- Specifying the hash type option while generating the CSR is newly supported.
- The "Generating self-signed certificates" topic is newly added.
- AES256 encryption is supported for DHCHAP secrets.
- The "Boot LUN zoning" topic is newly added.
- The "Traffic Isolation Zoning" chapter is completely revised and organized.
- The "vTap and QoS High Priority Zoning Compatibility mode" topic is newly added.
- The "Diagnostic Ports" chapter is updated.
- The "Inter-chassis Links" chapter is updated with Gen 6 support and Gen 5 to Gen 6 ICL connectivity support details.

# Understanding Fibre Channel Services

- Fibre Channel services overview.....25
- Management server.....26
- Platform services.....26
- Management server database.....27
- Topology discovery.....31
- Device login.....32
- High availability of daemon processes.....34
- FL\_Port and arbitrated loop support.....35

## Fibre Channel services overview

Fibre Channel services define service functions that reside at well-known addresses. A *well-known address* is a reserved three-byte address for each service. Services are provided to either nodes or management applications in the fabric.

FIGURE 1 Well-known addresses

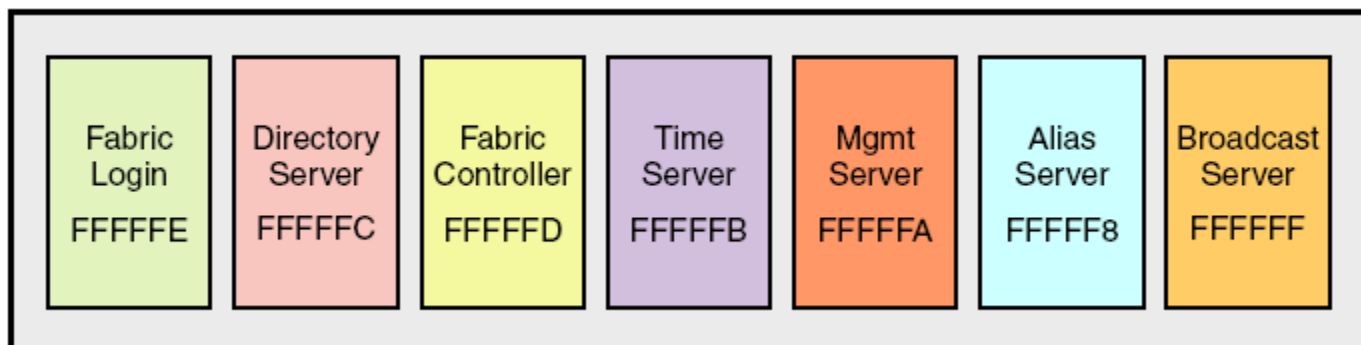

**Fabric Login** — The Fabric Login server assigns a fabric address to a fabric node, which allows it to communicate with services on the switch or other nodes in the fabric. The fabric address is a 24-bit address (0x000000) containing three 3-byte nodes. Reading from left to right, the first node (0x000000) represents the domain ID, the second node (0x000000) the port area number of the port where the node is attached, and the third node (0x000000) the arbitrated loop physical address (AL\_PA), if applicable.

**Directory server** — The directory server or name server registers fabric and public nodes and conducts queries to discover other devices in the fabric.

**Fabric controller** — The fabric controller provides State Change Notifications (SCNs) to registered nodes when a change in the fabric topology occurs.

**Time server** — The time server sends the time to the member switches in the fabric from either the principal switch or, if configured, the primary fabric configuration server (FCS) switch. Refer to [Configuring Security Policies](#) on page 215 for additional information on FCS policies.

**Management server** — The management server provides a single point for managing the fabric. This is the only service that users can configure. Refer to [Management server](#) on page 26 for more details.

Alias server — The alias server keeps a group of nodes registered as one name to handle multicast groups.

Broadcast server — The broadcast server is optional. When frames are transmitted to this address, they are broadcast to all operational N\_ and NL\_Ports.

When registration and query frames are sent to a well-known address, a different protocol service, Fibre Channel Common Transport (FC-CT), is used. This protocol provides a simple, consistent format and behavior when a service provider is accessed for registration and query purposes.

## Management server

The Brocade Fabric OS management server (MS) allows a SAN management application to retrieve information and administer interconnected switches, servers, and storage devices. The management server assists in the autodiscovery of switch-based fabrics and their associated topologies.

A client of the management server can find basic information about the switches in the fabric and use this information to construct topology relationships. The management server also allows you to obtain certain switch attributes and, in some cases, modify them. For example, logical names identifying switches can be registered with the management server.

The management server provides several advantages for managing a Fibre Channel fabric:

- It is accessed by an external Fibre Channel node at the well-known address *FFFFFAh*, so an application can access information about the entire fabric management with minimal knowledge of the existing configuration.
- It is replicated on every Brocade switch within a fabric.
- It provides an unzoned view of the overall fabric configuration. This fabric topology view exposes the internal configuration of a fabric for management purposes; it contains interconnect information about switches and devices connected to the fabric. Under normal circumstances, a device (typically an FCP initiator) queries the name server for storage devices within its member zones. Because this limited view is not always sufficient, the management server provides the application with a list of the entire name server database.

## Platform services

By default, all management services except platform services are enabled; the MS platform service and topology discovery are disabled.

You can activate and deactivate the platform services throughout the fabric. Activating the platform services attempts to activate the MS platform service for each switch in the fabric. The change takes effect immediately and is committed to the configuration database of each affected switch. MS activation is persistent across power cycles and reboots.

### NOTE

The commands **msplMgmtActivate** and **msplMgmtDeactivate** are allowed only in ADO and AD255.

## Platform services and Virtual Fabrics

Each logical switch has a separate platform database. All platform registrations done to a logical switch are valid only in that particular logical switch's Virtual Fabric.

Activating the platform services on a switch activates the platform services on all logical switches in a Virtual Fabric. Similarly, deactivating the platform services deactivates the platform service on all logical switches in a Virtual Fabric. The **msPlatShow** command displays all platforms registered in a Virtual Fabric.

## Enabling platform services

When FCS policy is enabled, the **msplMgmtActivate** command can be issued only from the primary FCS switch.

1. Connect to the switch and log in using an account assigned to the admin role.
2. Enter the **msCapabilityShow** command to verify that all switches in the fabric support the MS platform service; otherwise, the next step fails.
3. Enter the **msplMgmtActivate** command, as in the following example.

```
switch:admin> msplmgmtactivate
Request to activate MS Platform Service in progress.....
*Completed activating MS Platform Service in the fabric!
```

## Disabling platform services

Use the following procedure to disable platform services:

1. Connect to the switch and log in using an account assigned to the admin role.
2. Enter the **msplMgmtDeactivate** command.
3. Enter **y** to confirm the deactivation, as in the following example.

```
switch:admin> msplmgmtdeactivate

MS Platform Service is currently enabled.
This will erase MS Platform Service configuration
information as well as database in the entire fabric.
Would you like to continue this operation? (yes, y, no, n): [no] y

Request to deactivate MS Platform Service in progress.....
*Completed deactivating MS Platform Service in the fabric!
```

## Management server database

You can control access to the management server database.

An access control list (ACL) of WWN addresses determines which systems have access to the management server database. The ACL typically contains those WWNs of host systems that are running management applications.

If the list is empty (the default), the management server is accessible to all systems connected in-band to the fabric. For more access security, you can specify WWNs in the ACL so that access to the management server is restricted to only those WWNs listed.

### NOTE

The management server is logical switch-capable. All management server features are supported within a logical switch.

## Displaying the management server ACL

Use the following procedure to display the management server ACL:

1. Connect to the switch and log in using an account assigned to the admin role.
2. Enter the **msConfigure** command.  
The command becomes interactive.
3. At the "select" prompt, enter **1** to display the access list.

A list of WWNs that have access to the management server is displayed.

The following is an example of an empty access list

```
switch:admin> msconfigure
0      Done
1      Display the access list
2      Add member based on its Port/Node WWN
3      Delete member based on its Port/Node WWN
select : (0..3) [1] 1
MS Access list is empty.
0      Done
1      Display the access list
2      Add member based on its Port/Node WWN
3      Delete member based on its Port/Node WWN
select : (0..3) [1] 0
done ...
```

## Adding a member to the ACL

Use the following procedure to add a member to the ACL:

1. Connect to the switch and log in using an account assigned to the admin role.
2. Enter the **msConfigure** command.  
The command becomes interactive.
3. At the "select" prompt, enter **2** to add a member based on its port/node WWN.
4. At the "Port/Node WWN" prompt, enter the WWN of the host to be added to the ACL.
5. At the "select" prompt, enter **1** to display the access list so you can verify that the WWN you entered was added to the ACL.
6. After verifying that the WWN was added correctly, enter **0** at the prompt to end the session.
7. At the "Update the FLASH?" prompt, enter **y**.
8. Press **Enter** to update the nonvolatile memory and end the session.



The following is an example of adding a member to the management server ACL

```

switch:admin> msconfigure
0      Done
1      Display the access list
2      Add member based on its Port/Node WWN
3      Delete member based on its Port/Node WWN
select : (0..3) [1] 2
Port/Node WWN (in hex): [00:00:00:00:00:00:00:00] 20:00:00:20:37:65:ce:aa
*WWN is successfully added to the MS ACL.
0      Done
1      Display the access list
2      Add member based on its Port/Node WWN
3      Delete member based on its Port/Node WWN
select : (0..3) [2] 1
MS Access List consists of (14): {
 20:00:00:20:37:65:ce:aa
 20:00:00:20:37:65:ce:bb
 20:00:00:20:37:65:ce:ff
 20:00:00:20:37:65:ce:11
 20:00:00:20:37:65:ce:22
 20:00:00:20:37:65:ce:33
 20:00:00:20:37:65:ce:44
 10:00:00:60:69:04:11:24
 10:00:00:60:69:04:11:23
 21:00:00:e0:8b:04:70:3b
 10:00:00:60:69:04:11:33
 20:00:00:20:37:65:ce:55
 20:00:00:20:37:65:ce:66
 00:00:00:00:00:00:00:00
}
0      Done
1      Display the access list
2      Add member based on its Port/Node WWN
3      Delete member based on its Port/Node WWN
select : (0..3) [1] 0
done ...
Update the FLASH? (yes, y, no, n): [yes] y
*Successfully saved the MS ACL to the flash.

```

## Deleting a member from the ACL

When you delete a member from the ACL, that member no longer has access to the management server.

### NOTE

If you delete the last member of the ACL, leaving the ACL list is empty, then the management server will be accessible to all systems connected in-band to the fabric.

1. Connect to the switch and log in using an account with admin permissions.
2. Enter the **msConfigure** command.  
The command becomes interactive.
3. At the "select" prompt, enter **3** to delete a member based on its port/node WWN.
4. At the "Port/Node WWN" prompt, enter the WWN of the member to be deleted from the ACL.
5. At the "select" prompt, enter **1** to display the access list so you can verify that the WWN you entered was deleted from the ACL.
6. After verifying that the WWN was deleted correctly, enter **0** at the "select" prompt to end the session.
7. At the "Update the FLASH?" prompt, enter **y**.
8. Press **Enter** to update the nonvolatile memory and end the session.

The following is an example of deleting a member from the management server ACL

```
switch:admin> msconfigure
0      Done
1      Display the access list
2      Add member based on its Port/Node WWN
3      Delete member based on its Port/Node WWN
select : (0..3) [1] 3

Port/Node WWN (in hex): [00:00:00:00:00:00:00:00] 10:00:00:00:c9:29:b3:84

*WWN is successfully deleted from the MS ACL.
0      Done
1      Display the access list
2      Add member based on its Port/Node WWN
3      Delete member based on its Port/Node WWN
select : (0..3) [3] 1

MS Access list is empty
0      Done
1      Display the access list
2      Add member based on its Port/Node WWN
3      Delete member based on its Port/Node WWN
select : (0..3) [1] 0
```

## Viewing the contents of the management server database

Use the following procedure to view the contents of the management server database:

1. Connect to the switch and log in using an account assigned to the admin role.
2. Enter the **msPlatShow** command.

Example of viewing the contents of the management server platform database

Example of viewing the contents of the management server platform database

```
switch:admin> msplatshow

-----
Platform Name: [9] "first obj"
Platform Type: 5 : GATEWAY
Number of Associated M.A.: 1
[35] "http://java.sun.com/products/plugin"
Number of Associated Node Names: 1
Associated Node Names:
10:00:00:60:69:20:15:71
-----

Platform Name: [10] "second obj"
Platform Type: 7 : HOST_BUS_ADAPTER
Number of Associated M.A.: 1
Associated Management Addresses:
[30] "http://java.sun.com/products/1"
Number of Associated Node Names: 1
Associated Node Names:
10:00:00:60:69:20:15:75
```

## Clearing the management server database

Use the following procedure to clear the management server database:

### NOTE

The command **msPIClearDB** is allowed only in ADO and AD255.

1. Connect to the switch and log in using an account assigned to the admin role.
2. Enter the **msplClearDb** command.
3. Enter **y** to confirm the deletion.

The management server platform database is cleared.

## Topology discovery

The topology discovery feature can be displayed, enabled, and disabled; it is disabled by default. The commands **mstdEnable** and **mstdDisable** are allowed only in ADO and AD255.

### Displaying topology discovery status

Use the following procedure to display the status of the topology discovery:

1. Connect to the switch and log in using an account with admin permissions.
2. Enter the **mstdReadConfig** command.

```
switch:admin> mstdreadconfig
*MS Topology Discovery is Enabled.
```

### Enabling topology discovery

Use the following procedure to enable topology discovery:

1. Connect to the switch and log in using an account with admin permissions.
2. Enter the appropriate following command based on how you want to enable discovery:
  - For the local switch, enter the **mstdEnable** command.
  - For the entire fabric, enter the **mstdEnable all** command.

Example of enabling discovery

```
switch:admin> mstdenable

Request to enable MS Topology Discovery Service in progress....
*MS Topology Discovery enabled locally.
switch:admin> mstdenable ALL

Request to enable MS Topology Discovery Service in progress....
*MS Topology Discovery enabled locally.
*MS Topology Discovery Enable Operation Complete!!
```

### Disabling topology discovery

To disable topology discovery, complete the following steps.

1. Connect to the switch and log in using an account with admin permissions.
2. Enter the appropriate following command based on how you want to disable discovery:
  - For the local switch, enter the **mstdDisable** command.
  - For the entire fabric, enter the **mstdDisable all** command.

A warning displays stating that all NID entries might be cleared.

- Enter **y** to disable the Topology Discovery feature.

**NOTE**

Topology discovery is disabled by default.

**ATTENTION**

Disabling discovery of management server topology might erase all node ID entries.

## Example of disabling discovery

The following example shows what happens when you disable topology discovery.

```
switch:admin> mstddisable
This may erase all NID entries. Are you sure? (yes, y, no, n): [no] y

Request to disable MS Topology Discovery Service in progress....
*MS Topology Discovery disabled locally.

switch:admin> mstddisable all
This may erase all NID entries. Are you sure? (yes, y, no, n): [no] y

Request to disable MS Topology Discovery Service in progress....
*MS Topology Discovery disabled locally.
*MS Topology Discovery Disable Operation Complete!!
```

## Device login

A device can be storage, a host, or a switch. When new devices are introduced into the fabric, they must be powered on and, if a host or storage device, connected to a switch. Switch-to-switch logins (using the E\_Port) are handled differently than storage and host logins. E\_Ports exchange different frames than the ones listed below with the Fabric Controller to access the fabric. Once storage and host devices are powered on and connected, the following logins occur:

- FLOGI — Fabric Login command establishes a 24-bit address for the device logging in, and establishes buffer-to-buffer credits and the class of service supported.
- PLOGI — Port Login command logs the device into the name server to register its information and query for devices that share its zone. During the PLOGI process, information is exchanged between the new device and the fabric. Some of the following types of information exchanges occur:
  - SCR — State Change Registration registers the device for State Change Notifications. If a change in the fabric occurs, such as a zoning change or a change in the state of a device to which this device has access, the device receives a Registered State Change Notification (RSCN).
  - Registration — A device exchanges registration information with the name server.
  - Query — Devices query the name server for information about the device it can access.

## Principal switch

In a fabric with multiple switches, and one inter-switch link (ISL) exists between any two switches, a principal switch is automatically elected. The principal switch provides the following capabilities:

- Maintains time for the entire fabric. Subordinate switches synchronize their time with the principal switch. Changes to the clock server value on the principal switch are propagated to all switches in the fabric.
- Manages domain ID assignment within the fabric. If a switch requests a domain ID that has been used before, the principal switch grants the same domain ID unless it is in use by another switch.

## E\_Port login process

An E\_Port does not use a FLOGI to log in to another switch. Instead, the new switch exchanges frames with the neighboring switch to establish that the new switch is an E\_Port and that it has information to exchange. If everything is acceptable to the neighboring switch, it replies to the new switch with an SW\_ACC (accept) frame. The initializing frame is an Exchange Link Parameters (ELP) frame that allows an exchange of parameters between two ports, such as flow control, buffer-to-buffer credits, RA\_TOV, and ED\_TOV. This is not a negotiation. If one or the other port's link parameters do not match, a link does not occur. Once an SW\_ACC frame is received from the neighboring switch, the new switch sends an Exchange Switch Capabilities (ESC) frame. The two switches exchange routing protocols and agree on a common routing protocol. An SW\_ACC frame is received from the neighboring switch and the new switch sends an Exchange Fabric Parameters (EFP) frame to the neighboring switch, requesting principal switch priority and the domain ID list. Buffer-to-buffer credits for the device and switch ports are exchanged in the SW\_ACC command sent to the device in response to the FLOGI.

## Fabric login process

A device performs a fabric login (FLOGI) to determine if a fabric is present. If a fabric is detected then it exchanges service parameters with the fabric controller. A successful FLOGI sends back the 24-bit address for the device in the fabric. The device must issue and successfully complete a FLOGI command before communicating with other devices in the fabric.

Because the device does not know its 24-bit address until after the FLOGI, the source ID (SID) in the frame header of the FLOGI request are zeros (0x000000).

## Port login process

The steps in the port initialization process occur as the result of a protocol that functions to discover the type of device connected and establish the port type and negotiate port speed. See [Port Types](#) on page 73 for a discussion of available port types.

The Fibre Channel protocol (FCP) auto discovery process enables private storage devices that accept the process login (PRLI) to communicate in a fabric.

If device probing is enabled, the embedded port performs a PLOGI and attempts a PRLI into the device to retrieve information to enter into the name server. This enables private devices that do not explicitly register with the Name Server (NS) to be entered in the NS and receive full fabric access.

A fabric-capable device registers its information with the name server during a FLOGI. These devices typically register information with the name server before querying for a device list. The embedded port still performs a PLOGI and attempts a PRLI with these devices.

If a port decides to end the current session, it initiates a logout. A logout concludes the session and terminates any work in progress associated with that session.

To display the contents of a switch's name server, use the **nsShow** or **nsAllShow** command. For more information about these commands, refer to the *Fabric OS Command Reference*.

## RSCNs

A Registered State Change Notification (RSCN) is a notification frame that is sent to devices that are zoned together and are registered to receive a State Change Notification (SCN). The RSCN is responsible for notifying all devices of fabric changes. The following general list of actions can cause an RSCN to be sent through your fabric:

- A new device has been added to the fabric.
- An existing device has been removed from the fabric.
- A zone has changed.
- A switch name has changed or an IP address has changed.

- Nodes leaving or joining the fabric, such as zoning, powering on or shutting down a device, or zoning changes.

#### NOTE

Fabric reconfigurations with no domain change do not cause an RSCN.

## Duplicate Port World Wide Name

According to Fibre Channel standards, the Port World Wide Name (PWWN) of a device cannot overlap with that of another device, thus having duplicate PWWNs within the same fabric is an illegal configuration.

If a PWWN conflict occurs with two devices attached to the same domain, Fabric OS handles device login in such a way that only one device may be logged in to the fabric at a time. For more information, refer to [Duplicate PWWN handling during device login](#) on page 101.

If a PWWN conflict occurs and two duplicate devices are attached to the fabric through different domains, the devices are removed from the Name Server database and a RASlog is generated.

## Device recovery

To recover devices that have been removed from the Name Server database due to duplicate PWWNs, the devices must re-login to the fabric. This is true for any device—for example, a device on an F\_Port, NPIV devices, or devices attached to a switch in Access Gateway mode.

## High availability of daemon processes

Starting non-critical daemons is automatic; you cannot configure the startup process. The following sequence of events occurs when a non-critical daemon fails:

1. A RASlog and AUDIT event message are logged.
2. The daemon is automatically started again.
3. If the restart is successful, then another message is sent to RASlog and AUDIT reporting the successful restart status.
4. If the restart fails, another message is sent to RASlog and no further attempts are made to restart the daemon. You can then schedule downtime and reboot the switch at your convenience.

The following table lists the daemons that are considered non-critical and are automatically restarted on failure.

**TABLE 1** Daemons that are automatically restarted

Daemon	Description
arrd	Asynchronous Response Router, which is used to send management data to hosts when the switch is accessed through the APIs (FA API or SMI-S).
cald	Common Access Layer daemon, which is used by manageability applications.
raslogd	Reliability, Availability, and Supportability daemon logs error detection, reporting, handling, and presentation of data into a format readable by you and management tools.
rpcd	Remote Procedure Call daemon, which is used by the API (Fabric Access API and SMI-S).
snmpd	Simple Network Management Protocol daemon.
npd	Flow Vision daemon.

**TABLE 1** Daemons that are automatically restarted (continued)

Daemon	Description
traced	Trace daemon provides trace entry date and time translation to Trace Device at startup and when date/time changed by command. Maintains the trace dump trigger parameters in a Trace Device. Performs the trace Background Dump, trace automatic FTP, and FTP "aliveness check" if auto-FTP is enabled.
webd	Webserver daemon used for Web Tools (includes httpd as well).
weblinkerd	Weblinker daemon provides an HTTP interface to manageability applications for switch management and fabric discovery.

## FL\_Port and arbitrated loop support

The following information applies to FL\_Ports and arbitrated loops.

- FL\_Ports are not supported on Brocade FC32-48, FC16-32, FC16-48, FC16-64, SX6, Brocade 6505, Brocade 6510, Brocade 6520, Brocade G620, or Brocade 7840 platforms.
- VE\_Ports on the FX8-24 platforms do not support arbitrated loops.





# Performing Basic Configuration Tasks

---

• Fabric OS overview.....	37
• Fabric OS command line interface.....	37
• Password modification.....	45
• The switch Ethernet interface .....	46
• Date and time settings.....	56
• Domain IDs.....	61
• Switch names.....	63
• Chassis names.....	63
• Fabric name.....	64
• Switch activation and deactivation.....	64
• Device shutdown.....	66
• Basic connections.....	67

## Fabric OS overview

This chapter describes how to configure your Brocade SAN using the Fabric OS command line interface (CLI). Before you can configure a storage area network (SAN), you must power up the Backbone platform or switch and blades, and then set the IP addresses of those devices. Although this chapter focuses on configuring a SAN using the CLI, you can also use the following methods to configure a SAN:

- **Web Tools**

For Web Tools procedures, refer to the *Web Tools Administrator's Guide*.

- **Brocade Network Advisor**

For additional information, refer to the *Brocade Network Advisor User Manual* for the version you have.

- **A third-party application using the API**

For third-party application procedures, refer to the third-party API documentation.

Because of the differences between fixed-port and variable-port devices, procedures sometimes differ among Brocade models. As new Brocade models are introduced, new features sometimes apply only to those models.

When procedures or parts of procedures apply to some models but not others, this guide identifies the specifics for each model. For example, a number of procedures that apply only to variable-port devices are found in [Performing Advanced Configuration Tasks](#) on page 69.

Although many different software and hardware configurations are tested and supported by Brocade Communications Systems, Inc., documenting all possible configurations and scenarios is beyond the scope of this document. In some cases, earlier releases are highlighted to present considerations for interoperating with them.

The hardware reference manuals for Brocade products describe how to power up devices and set their IP addresses. After the IP address is set, you can use the CLI procedures contained in this guide. For additional information about the commands used in the procedures, refer to the *Fabric OS Command Reference*.

## Fabric OS command line interface

Fabric OS uses Role-Based Access Control (RBAC) to control access to all Fabric OS operations. Each feature is associated with an RBAC role and you need to know which role is allowed to run a command, make modifications to the switch, or view the output of the command. To determine which RBAC role you need to run a command, review the section [Role-Based Access Control](#) on page 145.

Note the following about the command display in this guide:

- The entire command line (both commands and options) is case-sensitive. Selected command names and options may also support Java-style capitalization. Java-style capitalization means that while **bannershow** and **bannerShow** will both work, **BANNERSHOW** and **BannerShow** will not. Refer to the *Fabric OS Command Reference* for explicit instructions on supported capitalization for each command.
- When command examples in this guide show user input enclosed in quotation marks, the quotation marks are required. For example: **zonecreate** *zonename* requires that the value for zonename be in quotation marks.

## Console sessions using the serial port

Be aware of the following behaviors for serial connections:

- Some procedures require that you connect through the serial port; for example, setting the IP address or setting the boot PROM password.
- **Brocade DCX 8510 and X6 Backbone families:** You can connect to CPO or CP1 using either of the two serial ports.

## Connecting to Fabric OS through the serial port

Use the following procedure to connect to the Fabric OS using the serial port:

### NOTE

If you connect the serial console port to a terminal server, ensure that flow control is disabled.

1. Connect the serial cable to the serial port on the switch and to an RS-232 serial port on the workstation.

If the serial port on the workstation is an RJ-45 port, instead of RS-232, remove the adapter on the end of the serial cable and insert the exposed RJ-45 connector into the RJ-45 serial port on the workstation.

2. Open a terminal emulator application (such as HyperTerminal on a PC, or TERM, TIP, or Kermit in a UNIX environment), and configure the application as follows:

- In a UNIX environment, enter the following string at the prompt:

```
tip /dev/ttyb -9600
```

If **ttyb** is already in use, enter **ttya** instead and enter the following string at the prompt:

```
tip /dev/ttya -9600
```

- In a Windows environment enter the following parameters:

Parameter	Value
Bits per second	9600
Data bits	8
Parity	None
Stop bits	1
Flow control	None

## Telnet or SSH sessions

You can connect to the Fabric OS through a Telnet or SSH connection or by using a console session on the serial port. The switch must also be physically connected to the network. If the switch network interface is not configured or the switch has been disconnected from the network, use a console session on the serial port as described in [Console sessions using the serial port](#) on page 38.



1. Connect through a serial port to the switch that is appropriate for your fabric:
  - If Virtual Fabrics is enabled, log in using an admin account assigned the chassis-role permission.
  - If Virtual Fabrics is not enabled, log in using an account assigned to the admin role.
2. Verify the switch's network interface is configured and that it is connected to the IP network through the RJ-45 Ethernet port.  
Switches in the fabric that are not connected through the Ethernet port can be managed through switches that are using IP over Fibre Channel. The embedded port must have an assigned IP address.
3. Log off the switch's serial port.
4. From a management station, open a Telnet connection using the IP address of the switch to which you want to connect.  
The login prompt is displayed when the Telnet connection finds the switch in the network.
5. Enter the account ID at the login prompt.
6. Enter the password.  
If you have not changed the system passwords from the default, you are prompted to change them. Enter the new system passwords, or press **Ctrl+C** to skip the password prompts. For more information on system passwords, refer to [Default account passwords](#) on page 46.
7. Verify the login was successful.  
The prompt displays the switch name and user ID to which you are connected.

```
login: admin
password: xxxxxxxx
```

## Getting help on a command

You can display a list of all command help topics for a given login level. For example, if you log in as user and enter the **help** command, a list of all user-level commands that can be executed is displayed. The same rule applies to the admin, securityAdmin, and the switchAdmin roles.

1. Connect to the switch and log in using an account assigned to the admin role.
2. Enter the **help** command with no specific command and all commands are displayed.

The optional **|more** argument displays the commands one page at a time.

For command-specific information, enter the **help** command and specify the command for which you need specific information.

```
help
command
|more
```

The commands in the following table provide help files for the indicated specific topics.

**TABLE 2** Help topic contents

Topic name	Help contents description
<b>diagHelp</b>	Diagnostic help information
<b>fcipHelp</b>	FCIP help information
<b>ficonHelp</b>	FICON help information
<b>mapsHelp</b>	MAPS help information
<b>routeHelp</b>	Routing help information
<b>secHelp</b>	Security help information

TABLE 2 Help topic contents (continued)

Topic name	Help contents description
zoneHelp	Zoning help information

## Viewing a history of command line entries

The CLI command history log file saves the last 1680 commands from all users on a FIFO basis, and this log is persistent across reboots and firmware downloads. This command is also supported for standby CPs.

The log records the following information whenever a command is entered in the switch CLI:

- Timestamp
- User name
- IP address of the Telnet session
- Options
- Arguments

Use the following procedure to view the CLI command log:

1. Connect to the switch and log in.
2. Enter the **cliHistory** command with the desired argument (refer to the following arguments for the **cliHistory** command). Entering no specific argument displays only the command line history of the currently logged-in user.

### NOTE

Commands entered through an interactive SSH login session are recorded in the command line history. However, if a command is entered as a single line with SSH login (for example, `ssh admin@10.20.x.x switchshow`), the entire command is not recorded.

## cliHistory

Entering **cliHistory** with no keywords displays the command line history for the currently logged-in user only. This is true for the root user account as well.

The following example shows the output of the **cliHistory** command for the root login.

```
switch:root> clihistory

CLI history
Date & Time                Message
Thu Sep 27 04:58:00 2012    root, 10.70.12.101, firmwareshow -v
Thu Sep 27 04:58:19 2012    root, 10.70.12.101, telnet 127.1.10.1
Thu Sep 27 05:25:45 2012    root, 10.70.12.101, ipaddrshow]
```

The following example shows the output of the **cliHistory** command for the admin login.

```
switch:admin> clihistory

CLI history
Date & Time                Message
Thu Sep 27 10:14:41 2012    admin, 10.70.12.101, clihistory
Thu Sep 27 10:14:48 2012    admin, 10.70.12.101, clihistory --show
```

The following example shows the output of the **cliHistory** command with FIDs in virtual fabric mode.

```
switch:admin> clihistory

CLI history
Date & Time                Message
```

```

Fri Sep 19 09:41:08 2014      root, FID 128, console, clihistory --clear
Fri Sep 19 09:41:41 2014      root, FID 128, console, lscfg --create 10
Fri Sep 19 09:42:10 2014      root, FID 128, console, lscfg --create 120
Fri Sep 19 09:42:54 2014      root, FID 128, console, lscfg --create 30
Fri Sep 19 09:42:59 2014      root, FID 128, console, setcontext 30
Fri Sep 19 09:43:14 2014      root, FID 30, console, rasdecode -m 65
Fri Sep 19 09:43:32 2014      root, FID 30, console, tracecfg -p -m 138
Fri Sep 19 09:43:42 2014      root, FID 30, console, setcontext 10

```

The following example shows the output of the **cliHistory** command without the FIDs in non-virtual fabric mode. The output shows that the **firmwareShow** and **errDump** commands were executed in non-virtual fabric mode.

```
switch:admin> clihistory
```

```

Fri Sep 19 09:43:53 2014      root, FID 10, console, tracedump
Fri Sep 19 09:43:59 2014      root, FID 10, console, coreshow
Fri Sep 19 09:44:21 2014      root, , console, firmwareshow
Fri Sep 19 09:44:25 2014      root, , console, errdump

```

### cliHistory --show

Using the **--show** keyword displays the same results as entering **cliHistory** alone.

### cliHistory --showuser username

Using the **--showuser** *username* keyword displays the command line history for the named user. This argument is available only to Root, Admin, and Securityadmin RBAC roles.

The following example shows the output of the **clihistory --showuser admin** for the "admin" user account.

```
switch:root> clihistory --showuser admin
```

```

CLI history
Date & Time                Message
Thu Sep 27 10:14:41 2012    admin, 10.70.12.101, clihistory
Thu Sep 27 10:14:48 2012    admin, 10.70.12.101, clihistory --show
Thu Sep 27 10:15:00 2012    admin, 10.70.12.101, clihistory

```

### cliHistory --showall

Using the **--showall** keyword displays the command line history for all users. This allows admin, factory, and securityadmin users to see the root user command history. This argument is available only to Root, Admin, and Securityadmin RBAC roles.

The following example displays the command history for all users.

```

switch:admin> clihistory --showall | more
CLI history

Date & Time                Message
Mon Oct 5 10:44:05 2015     admin, FID 128, 172.26.3.86, setcontext 20

Mon Oct 5 10:44:17 2015     admin, FID 20, 172.26.3.86, firmwareshow
Mon Oct 5 10:44:32 2015     admin, FID 20, 172.26.3.86, islshow
Mon Oct 5 10:44:20 2015     admin, FID 20, 172.26.3.86, version
Mon Oct 5 10:44:36 2015     admin, FID 20, 172.26.3.86, switchshow

Mon Oct 5 10:44:40 2015     admin, FID 20, 172.26.3.86, trunkshow

```

### cliHistory --help

Using the **--help** argument displays a list of the available command arguments.

The following example shows the output of the `clihistory --help` command.

```
swd77:admin> clihistory --help

clihistory usage:
clihistory:
Displays the CLI History of the current user
clihistory --show:
Displays the CLI History of the current user
clihistory --showuser <username>:
Displays the CLI History of the given user
clihistory --showall:
Displays the CLI History of all users
clihistory --clear:
Clears the CLI History of all users
clihistory --help:
Displays the command usage
```

## Notes

- SSH login CLI logs are not recorded in the command line history. For example,

```
ssh user@Ipaddr switchshow
```

- The CLI command log will be collected as part of any **supportSave** operation. The command long record of such an operation will be the equivalent of running `cliHistory --showall`.
- For commands that require a password (for example, the `firmwaredownload`, `configupload`, `configdownload`, and `supportsave` commands), only the command (and no arguments) is stored (refer to the following example for an illustration).

```
sw0:FID128:admin> firmwaredownload -s -p scp 10.70.4.109,fvt,/dist,pray4green
Server IP: 10.70.4.109, Protocol IPv4
Checking system settings for firmwaredownload...
Failed to access scp://fvt:*****@10.70.4.109//dist/release.plist

sw0:FID128:root> clihistory
Date & Time           Message
Wed May 23 03:39:37 2012    root, console, firmwaredownload
```

## Using fosexec to run commands on remote switches or domains

The **fosexec** command allows you to run Fabric OS commands on remote switches or domains across the fabric. Both the local and remote switches must be configured to send and receive remote command execution. You do not need to log in to the remote switch locally. The outputs of the commands are displayed in the local switch. The commands that you run using **fosexec** are also captured in the CLI history and audit logs of the remote switch.

The **fosexec** feature is a configurable feature. Using the **configure** command, you can configure the **fosexec** feature. The **fosexec** feature is off by default. The **fosexec** feature must be on in both the sending and receiving switches or domains. The configuration is checked when sending any **fosexec** request to a remote switch and also when receiving such a request from a remote switch. You can execute this command on either a specific switch or domain or all the switches or domains in the fabric. For a specific domain or switch, you must input the Domain ID (DID), which must be between 1 and 240.

The **configure** command has the following option under Configure CLI - Fabric Parameters section to enable or disable the remote **fosexec** feature:

```
sw_85:admin> configure

Not all options will be available on an enabled switch.
To disable the switch, use the "switchDisable" command.

Configure...

Fabric parameters (yes, y, no, n): [no] y
```

```

WWN Based persistent PID (yes, y, no, n): [no]
Location ID: (0..4) [0]
High Integrity Fabric Mode (yes, y, no, n): [no]
Edge Hold Time(Low(80ms), Medium(220ms), High(500ms), UserDefined(80-500ms): (80..500)
[220]
Remote Fosexec feature: (on, off): [off] on
D-Port Parameters (yes, y, no, n): [no] 2014/02/10-12:39:49, [CONF-1043], 1815, FID 128, INFO,
sw_85, Fabric Configuration Parameter Remote Fosexec feature changed to enabled
Zoning Operation parameters (yes, y, no, n): [no]
Commands executed via remote fosexec is captured in clihistory and audit logs of remote switch

```

The **fosexec** syntax is as follows:

```

fosexec --domain DID -cmd "cmd [args]"
fosexec --domain all -cmd "cmd [args]"

```

When nested quotes or strings must be provided, instead of using nested quotes, precede the string with an escape character or backward slash with quotes, as shown in the following example:

```

fosexec --domain all -cmd "CLIname --set \"SWAT Setup\""

```

The **fosexec** command has the following limitations:

- **fosexec** requires Fabric OS 7.3.0 or later on both the local and remote domains or switches.
- Remote execution is allowed based on RBAC checks or permissions for the remote domain role. The *RBAC permission denied* message is displayed for unsupported commands.
- Can be executed only by users with the *fabricadmin*, *admin*, or *root* roles or privileges and RBAC permissions.
- Does not work during remote domain or switch HA failover or reboot.
- Command syntax must match the command syntax supported by the remote switch.
- Commands with parameters specific to a switch or pizza box or chassis such as slot/port are not supported with the **all** option.
- Does not support interactive commands that require inputs in the middle of execution.
- Commands that take longer time to execute are not supported. The timeout period is 15 seconds.
- Returns only a maximum of 64 kilobytes of data from the remote switch. Any extra data gets truncated.
- Not supported in FIPS and Access Gateway modes.
- When you run **supportSave** through **fosexec**, wait for the execution to complete. To know whether the execution is completed, refer to the *RASLOG [SS-1000]* on all or the specific domain where **fosexec** is being run.
- The **fosexec** feature must be disabled to downgrade from Fabric OS 7.3.0 to any other earlier version.

#### NOTE

Running the **fosexec** command does not log you out from the current session in your local switch.



**Example 1**

```

sw_85:user9> fosexec --domain all -cmd "islshow"
Domain 19
=====
 1: 80-> 40 10:00:00:05:1e:0f:73:40 53 ls20d53_5100_8 sp:----- bw: 8.000G
 2: 81->289 10:00:00:05:33:0d:7b:02 4 ls20d4_plpl_8_4 sp:----- bw: 8.000G

Domain 23
=====
Remote fosexec feature is disabled.

Domain 53
=====
 1: 40-> 80 10:00:00:05:33:39:0d:da 19 ls20d19_5300_8 sp:----- bw: 8.000G
 2: 41->288 10:00:00:05:33:0d:7b:02 4 ls20d4_plpl_8_4 sp:----- bw: 16.000G

Domain 65
=====
Remote fosexec feature is disabled.
Domain 150
=====
 1: 0-> 38 10:00:00:27:f8:f1:15:c2 1 ls20d1_wedge_8 sp: 16.000G bw: 16.000G TRUNK QOS CR_RECOV FEC

Domain 1
=====
 1: 3-> 10 10:00:00:05:33:7a:4b:76 65 ls20d65_6510_8_47_58 sp: 8.000G bw: 16.000G TRUNK QOS
CR_RECOV
 2: 5-> 13 10:00:00:05:33:e5:56:2c 2 ls20d2_odin_8_39_58 sp: 16.000G bw: 16.000G TRUNK QOS
CR_RECOV FEC
 3: 6-> 42 10:00:00:05:33:0d:7b:02 4 ls20d4_plpl_8_47_30 sp: 16.000G bw: 16.000G TRUNK QOS
CR_RECOV FEC
 4: 22-> 12 10:00:00:05:33:e5:56:2c 2 ls20d2_odin_8_39_58 sp: 16.000G bw: 16.000G TRUNK QOS
CR_RECOV FEC
 5: 38-> 0 10:00:50:eb:1a:64:63:1f 150 ls20d150_amp_38_37_113 sp: 16.000G bw: 16.000G TRUNK QOS
CR_RECOV FEC
 6: 42-> 39 10:00:00:05:33:7a:4b:76 65 ls20d65_6510_8_47_58 sp: 8.000G bw: 8.000G TRUNK QOS
CR_RECOV

```

**Example 2**

```

sw_85:user9> fosexec --domain 19 -cmd "islshow"
 1: 80-> 40 10:00:00:05:1e:0f:73:40 53 ls20d53_5100_8 sp:----- bw: 8.000G
 2: 81->289 10:00:00:05:33:0d:7b:02 4 ls20d4_plpl_8_4 sp:----- bw: 8.000G

```

## Password modification

The switch automatically prompts you to change the default account passwords after logging in for the first time. If you do not change the passwords, the switch prompts you after each subsequent login until all the default passwords have been changed.

There is one set of default accounts for the entire chassis: admin, user, and root. Use the admin account when you log in to the switch for the first time and to perform basic configuration tasks. The user account is primarily used for basic system monitoring. The root account is reserved for development and manufacturing, or for debugging. For more information on the default accounts, refer to [Default accounts](#) on page 149.

**NOTE**

The passwords for the default accounts should be changed from their default values when prompted immediately following the login; these passwords cannot be changed using the **passwd** command later in the session, until the user has completed this step. If you skip this step, and then later decide to change the passwords, you will need to log out and then log back in. For root login, you are forced to change the default password.

**NOTE**

When you log in as admin and the default passwords are not changed, you are requested to change the default passwords only for admin and user accounts. You cannot change the default password for root account if you log in as admin. Default password for root account can be changed when you login as root.

## Default account passwords

The change default account passwords prompt is a string that begins with the message "Please change your passwords now". User-defined passwords can have from 8 through 40 characters. They must begin with an alphabetic character and can include numeric characters, the period (.), and the underscore (\_). They are case-sensitive, and they are not displayed when you enter them on the command line.

Record the passwords exactly as entered and store them in a secure place because recovering passwords requires significant effort and fabric downtime. Although the root account is not meant for general use, change their passwords if prompted to do so and save the passwords in case they are needed for recovery purposes.

## Changing the default account passwords at login

Use the following procedure to change the default account passwords.

1. Connect to the switch and log in using the default administrative account.
2. At each of the "Enter new password" prompts, either enter a new password or skip the prompt.

To skip a single prompt, press **Enter**. To skip all of the remaining prompts, press **Ctrl-C**.

**NOTE**

For root login, you cannot skip this step if the default password is present. You must change the default password.

The following example shows the output for changing passwords.

```
login: admin

Password:
Please change your passwords now.
Use Control-C to exit or press 'Enter' key to proceed.
Enter new password: <hidden>

Password changed.
Saving password to stable storage.
Password saved to stable storage successfully.
(output truncated)
```

## The switch Ethernet interface

The Ethernet (network) interface provides management access, including direct access to the Fabric OS CLI, and allows other tools, such as Web Tools, to interact with the switch. You can use either Dynamic Host Configuration Protocol (DHCP) or static IP addresses for the Ethernet network interface configuration.

## Brocade Directors

On Brocade DCX 8510 and X6 Directors, you must set IP addresses for the following components:

- Both Control Processors (CPO and CPI)
- Chassis management IP

## Brocade switches

On Brocade switches, you must set the Ethernet and chassis management IP interfaces.

Setting the chassis management IP address eliminates the need to know which CP is active and automatically connects the requestor to the currently active CP.

You can continue to use a static Ethernet addressing system or allow the DHCP client to automatically acquire Ethernet addresses. Configure the Ethernet interface IP address, subnet mask, and gateway addresses in one of the following manners:

- Using static Ethernet addresses (refer to [Static Ethernet addresses](#) on page 49)
- Activating DHCP (refer to [DHCP activation](#) on page 51)

### NOTE

When you change the Ethernet interface settings, open connections such as SSH or Telnet may be dropped. Reconnect using the new Ethernet IP address information or change the Ethernet settings using a console session through the serial port to maintain your session during the change. You must connect through the serial port to set the Ethernet IP address if the Ethernet network interface is not configured already. For details, refer to [Connecting to Fabric OS through the serial port](#) on page 38.

## Virtual Fabrics and the Ethernet interface

On the Brocade DCX 8510 Backbones and X6 Directors, the single-chassis IP address and subnet mask are assigned to the management Ethernet ports on the front panels of the CPs. These addresses allow access to the chassis--more specifically, the active CP of the chassis--and not individual logical switches. The IP addresses can also be assigned to each CP individually. This allows for direct communication with a CP, including the standby CP. Each CP has two management Ethernet ports on its front panel. These two physical ports are bonded together to create a single, logical Ethernet port, and it is the logical Ethernet port to which IP addresses are assigned.

IPv4 addresses assigned to individual Virtual Fabrics are assigned to IP over Fibre Channel (IPFC) network interfaces. In Virtual Fabrics environments, a single chassis can be assigned to multiple fabrics, each of which is logically distinct and separate from one another. Each IPFC point of connection to a given chassis needs a separate IPv4 address and prefix to be accessible to a management host. For more information on how to set up these IPFC interfaces to your Virtual Fabric, refer to [Managing Virtual Fabrics](#) on page 267.

## Management Ethernet port bonding

The two external Ethernet ports of a CP (CP8 or CPX6) blade can be bound together as a single logical network interface. This configuration uses an active-standby failover model to provide automatic failover support for the primary Ethernet port on the blade. If the primary Ethernet port fails (due to something other than power loss), the second Ethernet port immediately takes over to ensure link layer communication is retained.

One of the physical Ethernet ports is selected as the active interface. The second interface is set as the standby interface. All traffic is transmitted over the active interface. No traffic is transmitted over the standby interface, unless the active interface is determined to be no longer connected; at which point, the second interface is made active.

When active, all the Fabric OS kernel modules and applications on the CP blade will use the logical network interface named "bond0" instead of "eth0".

### NOTE

On bootup, physical port eth0 is always made active if it is connected.

The CP blade contains multiple Ethernet devices (including eth0 and eth3), which map to the two Ethernet ports on the front of the CP blade. Other Ethernet devices on the blade are reserved for use by the operating system.

The CP blade enables eth0 by default. If an error is encountered on eth0, it is treated the same as for any other port, unless the error causes the eth0 port to go down. If eth0 goes down, the eth3 interface becomes active and will remain active even if eth0 comes back up. Use one of the following actions to restore eth0 as the active interface.

- Unplug the network cable, wait 5 seconds, and then plug it back in.
- Perform a High Availability (HA) failover routine.
- Power down the switch and then power it back up again.

#### ATTENTION

Performing an HA failover and powering down the switch will cause a disruptive delay in content delivery.

## Supported Brocade Backbones and Directors

Management Ethernet port bonding is available on the following CP blades.

- CP8 blade installed on a Brocade DCX 8510 Backbone
- CPX6 blade installed on a Brocade X6 Director

## Setting up the second Ethernet port on a CP8 blade

The port speed and duplex mode between the Ethernet ports should always match. Both ports should be set at a fixed speed or set to autonegotiate.

1. Make sure that the speed and link operating mode settings are the same for both eth3 and eth0. Refer to [Setting the Ethernet interface mode and speed](#) on page 56 for instructions on setting port modes, and [Setting port speeds](#) on page 83 for instructions on setting port speeds.
2. Physically connect the second Ethernet port to the same network as the primary Ethernet port.

## Displaying the network interface settings

#### NOTE

If an IP address has not been assigned to the network interface (Ethernet), you must connect to the Fabric OS CLI using a console session on the serial port. For more information, see [Console sessions using the serial port](#) on page 38. Otherwise, connect using SSH.

1. Connect to the switch and log in using an account assigned to the admin role.
2. Enter **ipAddrShow**.

```
ipAddrShow
```

The following example shows the output of **ipAddrShow** for a Brocade Backbone:

```
ecp:admin> ipaddrshow

SWITCH
Ethernet IP Address: 10.1.2.3
Ethernet Subnetmask: 255.255.240.0
CP0
Ethernet IP Address: 10.1.2.3
Ethernet Subnetmask: 255.255.240.0
Host Name: ecp0
Gateway IP Address: 10.1.2.1
CP1
Ethernet IP Address: 10.1.2.4
Ethernet Subnetmask: 255.255.240.0
Host Name: ecp1
Gateway IP Address: 10.1.2.3
```

```

IPFC address for virtual fabric ID 123: 11.1.2.3/24
IPFC address for virtual fabric ID 45: 13.1.2.4/20
Slot 7
eth0: 11.1.2.4/24
Gateway: 11.1.2.1
Backplane IP address of CP0 : 10.0.0.5
Backplane IP address of CP1 : 10.0.0.6
IPv6 Autoconfiguration Enabled: Yes
Local IPv6 Addresses:
sw 0 stateless fd00:60:69bc:70:260:69ff:fe00:2/64 preferred
sw 0 stateless fec0:60:69bc:70:260:69ff:fe00:2/64 preferred
cp 0 stateless fd00:60:69bc:70:260:69ff:fe00:197/64 preferred
cp 0 stateless fec0:60:69bc:70:260:69ff:fe00:197/64 preferred
cp 1 stateless fd00:60:69bc:70:260:69ff:fe00:196/64 preferred
cp 1 stateless fec0:60:69bc:70:260:69ff:fe00:196/64 preferred
IPv6 Gateways:
cp 0 fe80:60:69bc:70::3
cp 0 fe80:60:69bc:70::2
cp 0 fe80:60:69bc:70::1
cp 1 fe80:60:69bc:70::3

```

If the Ethernet IP address, subnet mask, and gateway address are displayed, then the network interface is configured. Verify the information on your switch is correct. If DHCP is enabled, the network interface information was acquired from the DHCP server.

#### NOTE

You can use either IPv4 or IPv6 with a classless inter-domain routing (CIDR) block notation (also known as a *network prefix length*) to set up your IP addresses.

## Resetting the management network interface error counters

Fabric OS supports resetting the management network interface error counters only on Brocade 7840 Extension Switch and Gen-6 devices.

1. To reset the error counters, run the **ethif --resetError** command.

```

switch:admin> ethif --reseterror eth0
Statistics cleared for eth0

```

2. To display the error counters, run the **ethif --show** command.

```

switch:admin> ethif --show eth0

```

## Static Ethernet addresses

Use static Ethernet network interface addresses in environments where DHCP service is not available. To use static addresses for the Ethernet interface, you must first disable DHCP. You can enter static Ethernet information and disable DHCP at the same time. For more information, refer to [DHCP activation](#) on page 51.

If you choose not to use DHCP or to specify an IP address for your switch Ethernet interface, you can do so by entering "**none**" or "**0.0.0.0**" in the Ethernet IP address field.

On an application blade, configure the two external Ethernet interfaces to two different subnets. If two subnets are not present, configure one of the interfaces and leave the other unconfigured. Otherwise, the following message displays and blade status may go into a faulty state after a reboot.

```

Neighbor table overflow.
print: 54 messages suppressed

```

## Setting the static addresses for the Ethernet network interface

Use the following procedure to set the Ethernet network interface static addresses:

1. Connect to the switch and log in using an account assigned to the admin role.
2. Perform the appropriate action based on whether you have a switch or Backbone:
  - If you are setting the IP address for a switch, enter the **ipAddrSet** command.
  - If you are setting the IP address for a Backbone, enter the **ipAddrSet** command specifying either CPO or CP1. You must set the IP address for both CPO and CP1.

The following is an example of setting an IPv4 address

```
switch:admin> ipaddrset

Ethernet IP Address [10.1.2.3]:
Ethernet Subnetmask [255.255.255.0]:
Fibre Channel IP Address [220.220.220.2]:
Fibre Channel Subnetmask [255.255.0.0]:
Gateway IP Address [10.1.2.1]:
DHCP [OFF]: off
```

The following is an example of setting an IPv6 address on a switch

```
switch:admin> ipaddrset -ipv6 --add 1080::8:800:200C:417A/64

IP address is being changed...Done.
```

For more information on setting up an IP address for a Virtual Fabric, refer to [Managing Virtual Fabrics](#) on page 267.

3. Enter the network information in dotted-decimal notation for the Ethernet IPv4 address or in semicolon-separated notation for IPv6.
4. Enter the **Ethernet Subnetmask** at the prompt.
5. The Fibre Channel prompts are not relevant; you can skip them by pressing **Enter** .  
The Fibre Channel IP address is used for management.
6. Enter the **Gateway IP Address** at the prompt.
7. Disable DHCP by entering **off** .

## Setting the static addresses for the chassis management IP interface

Use the following procedure to set the chassis management IP interface static addresses:

1. Connect to the switch and log in using an account assigned to the admin role.
2. Enter the **ipAddrSet -chassis** command.

```
switch:admin>> ipaddrset -chassis
DHCP [Off]:
Ethernet IP Address [10.38.18.142]:
Ethernet Subnetmask [255.255.240.0]:
Committing configuration...Done.
```

3. Enter the network information in dotted-decimal notation for the Ethernet IPv4 address or in semicolon-separated notation for IPv6.
4. Enter the **Ethernet Subnetmask** at the prompt.

## DHCP activation

Some Brocade switches have Dynamic Host Configuration Protocol (DHCP) enabled by default.

The Fabric OS DHCP client conforms to the latest IETF Draft Standard RFCs for IPv4, IPv6, and DHCP, and supports the following parameters:

- External Ethernet port IP addresses and subnet masks
- Default gateway IP address

## Notes on DHCP

The following items need to be kept in mind when working with DHCP:

- The DHCP client uses a DHCP vendor-class identifier that allows DHCP servers to determine that the discover/request packet are coming from a Brocade switch. The vendor-class identifier is the string "BROCADE" followed by the SWBD model number of the platform. For example, the vendor-class identifier for a request from a Brocade G620 is "BROCADESWBD145."
- The DHCP client can obtain stateful IPv6 addresses.
- When DHCP is enabled, the switch name is registered to the Domain Name System (DNS) server automatically and the switch is assigned an IP address from the DHCP server. If the switch name is changed using the CLI, the DNS record in the DNS server is updated automatically. Dynamic DNS (DDNS) is the method used to automatically update a name server in the Domain Name System (DNS).

## Enabling DHCP for IPv4 in fixed-port devices

When you connect a DHCP-enabled switch to the network and power on the switch, the switch automatically obtains the Ethernet IP address, Ethernet subnet mask, and default gateway address from the DHCP server.

### NOTE

The DHCP client can only connect to a DHCP server on the same subnet as the switch. Do not enable DHCP if the DHCP server is not on the same subnet as the switch.

Enabling DHCP after the Ethernet information has been configured releases the current Ethernet network interface settings. These include the Ethernet IP address, Ethernet subnet mask, and gateway IP address. The Fibre Channel IP address and subnet mask are static and are not affected by DHCP; for instructions on setting the FC IP address, refer to [Static Ethernet addresses](#) on page 49.

1. Connect to the switch and log in using an account assigned to the admin role.
2. Enter the **ipAddrSet** command.

```
ipaddrset
```

### NOTE

Alternatively, you can enable DHCP for IPv4 by entering **ipaddrset -ipv4 -add -dhcp ON** as a single command. If you do so, you do not need to complete the following steps.

3. Enable DHCP by entering **on**.
4. You can confirm that the change has been made using the **ipAddrShow** command.

The following example enables DHCP for IPv4 interactively.

```
switch:admin> ipaddrset
DHCP [Off]:on
IP address is being changed...
Done.
```

The following example enables DHCP for IPv4 using a single command.

```
switch:admin> ipaddrset -ipv4 -add -dhcp ON
switch:admin> ipaddrshow

SWITCH
Ethernet IP Address: 10.20.134.219
Ethernet Subnetmask: 255.255.240.0
Gateway IP Address: 10.20.128.1
DHCP: On
```

## Disabling DHCP for IPv4 in fixed-port devices

When you disable DHCP, the previously configured static Ethernet IP address, the subnet mask, and the default gateway addresses are restored as active configuration.

1. Connect to the switch and log in using an account assigned to the admin role.
2. Enter the **ipAddrSet** command.

```
ipaddrset
```

### NOTE

Alternatively, you can disable DHCP for IPv4 by entering **ipaddrset -ipv4 -add -dhcp OFF** as a single command. If you do so, you do not need to complete the following steps.

3. When you are prompted for DHCP [On], disable it by entering **off**.
4. You can confirm that the change has been made using the **ipAddrShow** command.

The following example disables DHCP for IPv4 interactively.

```
switch:admin> ipaddrset
DHCP [On]:off
IP address is being changed...
Done.
```

The following example disables DHCP for IPv4 using a single command.

```
switch:admin> ipaddrset -ipv4 -add -dhcp OFF

switch:admin> ipaddrshow

SWITCH
Ethernet IP Address: 10.20.134.219
Ethernet Subnetmask: 255.255.240.0
Gateway IP Address: 10.20.128.1
DHCP: Off
```

## Enabling DHCP for IPv4 in Directors

To enable DHCP for IPv4 on Brocade DCX 8510 and X6 Directors, follow these steps.

1. Run the **ipAddrSet -chassis** command.

```
switch:admin> ipaddrset -chassis
DHCP [Off]:on
```



Info : This feature got enabled on all Management Interfaces of this chassis  
Done.

- To display the configured IP address, run the **ipAddrShow** command.

```
switch:admin>ipaddrshow
CHASSIS
Ethernet IP Address: 10.17.46.231
Ethernet Subnetmask: 255.255.240.0

CP0
Ethernet IP Address: 10.17.46.228
Ethernet Subnetmask: 255.255.240.0
Host Name: cp0
Gateway IP Address: 10.17.32.1

CP1
Ethernet IP Address: 10.17.46.229
Ethernet Subnetmask: 255.255.240.0
Host Name: cp1
Gateway IP Address: 10.17.32.1
```

- To disable DHCP for IPv4 on Directors, follow these steps.

When you disable DHCP, the previously configured static Ethernet IP address, the subnet mask, and the default gateway addresses are restored as active configuration.

- In interactive mode:

```
switch:admin>ipaddrset -chassis
DHCP [On]:off
IP address is being changed...
Done
```

- In a single command:

```
switch:admin>ipaddrset -chassis -ipv4 -add -dhcp off
IP address is being changed...
Done.
```

## Configuring DHCPv6 for IPv6

You can configure the IPv6 address from the DHCPv6 server.

- Run the **ipAddrSet -ipv6 -dhcpv6** command.
- To display the configured IPv6 address, run the **ipAddrShow** command.

- In case of fixed-port switches, the following output displayed:

```
switch:admin>ipaddrshow
SWITCH
Ethernet IP Address: 10.17.33.33
Ethernet Subnetmask: 255.255.240.0
Gateway IP Address: 10.17.32.1
DHCP: Off
IPv6 Autoconfiguration Enabled: No
Local IPv6 Addresses:
dhcpv6 2620:100:0:f603::f9ff/64 preferred
link local fe80::205:33ff:fe3a:77f9/64
IPv6 Gateways:
fe80::21b:edff:fe0b:9000
DHCPv6: On
```

- In case of Backbone Directors, the following output is displayed:

```
switch:admin>ipaddrshow
CHASSIS
```

```
Local IPv6 Addresses:
dhcpv6 2620:100:0:f603::f912/64 preferred
link local fe80::205:33ff:fe3a:77f9/64
```

```
CP0
Local IPv6 Addresses:
dhcpv6 2620:100:0:f603::f9fb/64 preferred
link local fe80::205:33ff:fe3a:77f8/64
IPv6 Gateways:
fe80::21b:edff:fe0b:9000
DHCpV6: On
```

```
CP1
Local IPv6 Addresses:
dhcpv6 2620:100:0:f603::f9fa/64 preferred
link local fe80::205:33ff:fe3a:77f7/64
IPv6 Gateways:
fe80::21b:edff:fe0b:9000
DHCpV6: On
```

3. To disable DHCPv6 for IPv6, run the following command.

```
ipaddrset -ipv6 -nodhcpv6
```

## Configuring Stateless DHCPv6

The configuration parameters such as DNS recursive name servers, DNS search list and SIP servers must be configured using stateless DHCPv6.

1. Run the **ipAddrSet -ipv6 -auto** command.
2. To display the configured IP address details, run the **ipAddrShow** command.
  - In case of fixed-port switches, the following output is displayed:

```
switch:admin> ipaddrshow
SWITCH
Ethernet IP Address: 10.17.33.33
Ethernet Subnetmask: 255.255.240.0
Gateway IP Address: 10.17.32.1
DHCP: Off
IPv6 Autoconfiguration Enabled: Yes
Local IPv6 Addresses:
dhcpv6 2620:100:0:f603::f9ff/64 preferred
stateless 2620:100:0:f602:227:f8ff:fef0:1800/64 preferred
link local fe80::205:33ff:fe3a:77f9/64
IPv6 Gateways:
fe80::21b:edff:fe0b:9000
DHCpV6: On
```

- In case of Directors, the following output is displayed:

```
switch:admin> ipaddrshow
CHASSIS
Ethernet IP Address: 10.17.46.217
Ethernet Subnetmask: 255.255.240.0

CP0
Ethernet IP Address: 10.17.46.240
Ethernet Subnetmask: 255.255.240.0
Host Name: cp0
Gateway IP Address: 10.17.32.1

CP1
Ethernet IP Address: 10.17.46.241
Ethernet Subnetmask: 255.255.240.0
Host Name: cp1
Gateway IP Address: 10.17.32.1
IPv6 Autoconfiguration Enabled: Yes
Local IPv6 Addresses:
```

```

chassis 0 dhcpv6 2620:100:0:f603::f1a2/64 preferred
cp 0 link local fe80::205:1eff:febf:7069/64
chassis 0 stateless 2620:100:0:f603:205:1eff:feb7:3c00/64 preferred
cp 0 static 2620:100:0:f603::f1a3/64 preferred
cp 0 stateless 2620:100:0:f603:205:1eff:febf:7069/64 preferred
cp 0 dhcpv6 2620:100:0:f603::f773/64 preferred
cp 1 link local fe80::205:1eff:febf:7068/64
cp 1 stateless 2620:100:0:f603:205:1eff:febf:7068/64 preferred
cp 1 dhcpv6 2620:100:0:f603::f49f/64 preferred
IPv6 Gateways:
cp 0 fe80::21b:edff:fe0b:3c00
cp 0 fe80::21b:edff:fe0b:9000
DHCIPv6: On

```

- To display the configuration parameters of DNS name servers, run the `dnsconfig --show` command.

```

switch:admin> dnsconfig --show
Domain Name Server Configuration Information
-----
Domain Name           = englab.brocade.com
Name Server IP Address = englab.brocade.com
Name Server IP Address = 10.31.2.10

```

## IPv6 autoconfiguration

IPv6 can assign multiple IP addresses to each network interface. Each interface is configured with a link local address in almost all cases, but this address is only accessible from other hosts on the same network. To provide for wider accessibility, interfaces are typically configured with at least one additional global scope IPv6 address. IPv6 autoconfiguration allows more IPv6 addresses, the number of which is dependent on the number of routers serving the local network and the number of prefixes they advertise.

There are two methods of autoconfiguration for IPv6 addresses: stateless autoconfiguration and stateful autoconfiguration. *Stateless autoconfiguration* allows an IPv6 host to obtain a unique address using the IEEE 802 MAC address. *Stateful autoconfiguration* uses a DHCPv6 server, which keeps a record of the IP address and other configuration information for the host. Whether a host engages in autoconfiguration and which method it uses is dictated by the routers serving the local network, not by a configuration of the host. There can be multiple routers serving the network, each potentially advertising multiple network prefixes. Thus, the host is not in full control of the number of IPv6 addresses that it configures, much less the values of those addresses, and the number and values of addresses can change as routers are added to or removed from the network.

When IPv6 autoconfiguration is enabled, the platform engages in stateless IPv6 autoconfiguration. When IPv6 autoconfiguration is disabled, the platform relinquishes usage of any autoconfigured IPv6 addresses that it may have acquired while it was enabled. This same enable or disable state also enables or disables the usage of a link local address for each managed entity, though a link local address continues to be generated for each nonchassis-based platform and for each CP of a chassis-based platform because those link local addresses are required for router discovery. The enabled or disabled state of autoconfiguration is independent of whether any static IPv6 addresses have been configured.

## Setting IPv6 autoconfiguration

Use the following procedure to enable IPv6 autoconfiguration:

- Connect to the switch and log in using an account with admin permissions.
- Take the appropriate following action based on whether you want to enable or disable IPv6 autoconfiguration:
  - Enter the `ipAddrSet -ipv6 -auto` command to enable IPv6 autoconfiguration for all managed entities on the target platform.
  - Enter the `ipAddrSet -ipv6 -noauto` command to disable IPv6 autoconfiguration for all managed entities on the target platform.

## Setting the Ethernet interface mode and speed

Network interfaces can be set to use one of three link operating modes: full duplex, half duplex, or autonegotiate.

Changing the link operating mode is not supported for all network interfaces or for all Ethernet network interfaces. On the CP blade in a Brocade Backbone, the supported interfaces are eth0 and eth3. On all other platforms, only eth0 is supported.

For dual-CP systems, the **ethif** command affects only the CP to which you are currently logged in. Therefore, to set the link operating mode on the active CP, you must issue the **ethif** command on the active CP; and to set the mode on the standby CP, you must issue the **ethif** command on the standby CP. During failover, the mode is retained separately for each CP because the physical links may be set to operate in different modes.

### ATTENTION

Forcing the link to an operating mode not supported by the network equipment to which it is attached may result in an inability to communicate with the system through its Ethernet interface. It is recommended that the **ethif** command be used only from the serial console port. When used through an interface other than the serial console port, the command displays a warning message and prompts for verification before continuing. This warning is not displayed and you are not prompted when the command is used through the serial console port.

Use the following procedure to set the mode of a port.

1. Connect to the switch and log in using an account with admin permissions.
2. Enter the **ethif** command.

### Example of setting the port mode to full autonegotiate

The following example sets the mode for eth3 to autonegotiate, and permits both full and half duplex modes to be selected at both 10, 100, and 1000 Mbps.

```
switch:admin> ethif --set eth3 -an on -speed 1000 -duplex full
an:on
speed:1000
cap:full
MII_CMD:-A
ADVERTISE:Advertise
DEFMODE:yes
auto:1
MII_MODE:1000baseTx-FD,
Committing configuration...done.
```

### Example of setting the port mode to 100 Mbps full duplex operation

The following example forces the link for the eth0 interface from autonegotiation to 100 Mbps half-duplex operation:

```
switch:admin> ethif --set eth0 -an on -speed 100 -duplex half
an:on
speed:100
cap:half
MII_CMD:-A
ADVERTISE:Advertise
DEFMODE:yes
auto:1
MII_MODE:100baseTx-FD,
Committing configuration...done.
```

## Date and time settings

Switches maintain the current date and time inside a battery-backed real-time clock (RTC) circuit that receives the date and time from the fabric's principal switch. Date and time are used for logging events. Switch operation does not depend on the date and time; a switch

with an incorrect date and time value functions properly. However, because the date and time are used for logging, error detection, and troubleshooting, you must set them correctly.

In a Virtual Fabric, there can be a maximum of eight logical switches per Backbone. Only the default switch in the chassis can update the hardware clock. When the **date** command is issued from a non-principal pre-Fabric OS v6.2.0 or earlier switch, the **date** command request is dropped by a Fabric OS v6.2.0 and later switch and the pre-Fabric OS v6.2.0 switch or earlier does not receive an error.

Authorization access to set or change the date and time for a switch is role-based. For an understanding of role-based access, refer to [Role-Based Access Control](#) on page 145.

## Setting the date and time

Use the following procedure to set the device date and time.

1. Connect to the switch and log in using an account assigned to the admin role.
2. Enter the **date** command, using the following syntax:

```
date "mmddHHMMyy"
```

The values represent the following:

- mm is the month; valid values are 01 through 12.
- dd is the date; valid values are 01 through 31.
- HH is the hour; valid values are 00 through 23.
- MM is minutes; valid values are 00 through 59.
- yy is the year, valid values are 00 through 37 and 70 through 99 (year values from 70 through 99 are interpreted as 1970 through 1999, year values from 00 through 37 are interpreted as 2000 through 2037).

The following example shows how to set a date.

```
switch:admin> date
Fri Sep 29 17:01:48 UTC 2007
Stealth200E:admin> date "0204101008"
Mon Feb 4 10:10:00 UTC 2008
```

## Time zone settings

You can set the time zone for a switch by name. You can specify the setting using country and city or time zone parameters. Switch operation does not depend on a date and time setting. However, having an accurate time setting is needed for accurate logging and audit tracking.

If the time zone is not set with new options, the switch retains the offset time zone settings. The **tsTimeZone** command includes an option to revert to the prior time zone format. For more information about the **tsTimeZone** command, refer to the *Fabric OS Command Reference*.

When you set the time zone for a switch, you can perform the following tasks:

- Display all of the time zones supported in the firmware.
- Set the time zone based on a country and city combination or based on a time zone ID, such as PST.

The time zone setting has the following characteristics:

- Users can view the time zone settings. However, only those with administrative permissions can set the time zones.
- The setting automatically adjusts for Daylight Savings Time.

- Changing the time zone on a switch updates the local time zone setup and is reflected in local time calculations.
- By default, all switches are set to Greenwich Mean Time (O,O). If all switches in a fabric are in one time zone, it is possible for you to keep the time zone setup at the default setting.
- System services that have already started reflect the time zone changes after the next reboot.
- Time zone settings persist across failover for high availability.
- Setting the time zone on any dual domain Backbone has the following characteristics:
  - Updating the time zone on any switch updates the entire Backbone.
  - The time zone of the entire Backbone is the time zone of switch O.

## Setting the time zone

The following procedure describes how to set the time zone for a switch. You must perform the procedure on *all* switches for which the time zone must be set. However, you only need to set the time zone once on each switch because the value is written to nonvolatile memory.

1. Connect to the switch and log in using an account assigned to the admin role and with the chassis-role permission.
2. Use the **tsTimeZone** command to review or set the time zone for the device.
  - Enter **tsTimeZone** with no parameters to display the current time zone setting.
  - Enter the **--interactive** option to list all of the time zones supported by the firmware.
  - Enter *timeZone\_fmt* to set the time zone by Country/City or by time zone ID, such as Pacific Standard Time (PST).

The following example displays and changes the time zone to US/Central.

```
switch:admin> tstimezone

Time Zone : US/Pacific
switch:admin> tstimezone US/Central

switch:admin> tstimezone

Time Zone : US/Central
```

## Setting the time zone interactively

Use the following procedure to set the current time zone to PST using interactive mode:

1. Connect to the switch and log in using an account assigned to the admin role and with the chassis-role permission.
2. Enter the **tsTimeZone --interactive** command.

You are prompted to select a general location.

```
Please identify a location so that time zone rules can be set correctly.
Please select a continent or ocean.
1) Africa
2) Americas
3) Antarctica
4) Arctic Ocean
5) Asia
6) Atlantic Ocean
7) Australia
8) Europe
9) Indian Ocean
10) Pacific Ocean
11) none - I want to specify the time zone using the POSIX TZ format.
Enter number or control-D to quit ?1
```

- Enter the appropriate **number** or press **Ctrl-D** to quit.

```

Please select a country.
1) Algeria          18) Gabon           35) Rwanda
2) Angola           19) Gambia         36) Sao Tome & Principe
3) Benin            20) Ghana          37) Senegal
4) Botswana         21) Guinea         38) Sierra Leone
5) Burkina Faso     22) Guinea-Bissau 39) Somalia
6) Burundi          23) Kenya         40) South Africa
7) Cameroon         24) Lesotho        41) Spain
8) Central African Rep. 25) Liberia        42) Sudan
9) Chad             26) Libya          43) Swaziland
10) Congo (Dem. Rep.) 27) Malawi         44) Tanzania
11) Congo (Rep.)    28) Mali           45) Togo
12) Cote d'Ivoire   29) Mauritania     46) Tunisia
13) Djibouti        30) Morocco        47) Uganda
14) Egypt           31) Mozambique     48) Western Sahara
15) Equatorial Guinea 32) Namibia        49) Zambia
16) Eritrea         33) Niger          50) Zimbabwe
17) Ethiopia        34) Nigeria
Enter number or control-D to quit ?1
The following information has been given:

```

```

                Algeria

```

```

Therefore TZ='Africa/Algiers' will be used.
Local time is now:      Wed Oct 28 15:01:38 CET 2015.
Universal Time is now: Wed Oct 28 14:01:38 UTC 2015.

```

- Select a country location at the prompt.
- Enter the appropriate number at the prompt to specify the time zone region. Enter **1** to confirm or **2** to restart the timezone selection again. Any time, **Ctrl-D** to quit.

```

Is the above information OK?
1) Yes
2) No
Enter number or control-D to quit ?2
Please identify a location so that time zone rules can be set correctly.
Please select a continent or ocean.
1) Africa
2) Americas
3) Antarctica
4) Arctic Ocean
5) Asia
6) Atlantic Ocean
7) Australia
8) Europe
9) Indian Ocean
10) Pacific Ocean
11) none - I want to specify the time zone using the POSIX TZ format.
Enter number or control-D to quit ?

```

## Network Time Protocol

To keep the time in your SAN current, you should synchronize the local time of the principal or primary FCS switch with at least one external Network Time Protocol (NTP) server.

The principal or primary FCS switch connects to the NTP server and broadcasts time service updates to all switches in the fabric. The other switches in the fabric automatically take their time from the principal or primary FCS switch.

You can synchronize the local time of the principal or primary FCS switch to a maximum of eight external NTP servers.

All switches in the fabric maintain the current NTP clock server value in nonvolatile memory. By default, this value is the local clock (LOCL) of the principal or primary FCS switch. Changes to the clock server value on the principal or primary FCS switch are propagated to all switches in the fabric.

When a new switch enters the fabric, the time server daemon of the principal or primary FCS switch sends out the addresses of all existing clock servers and the time to the new switch. When a switch enters the fabric, it stores the list and the active servers.

If Virtual Fabrics is enabled, the switch behavior is as follows:

- All switches in a given chassis must be configured for the same set of NTP servers. This ensures that time does not go out of sync in the chassis. It is not recommended to configure LOCL in the NTP server list.
- All default switches in the fabric can query the NTP server. If Virtual Fabrics is not enabled, only the principal or primary FCS switch can query the NTP server.
- The logical switches in a chassis get their clock information from the default logical switch, and not from the principal or primary FCS switch.

## Synchronizing the local time with an external source

The **tsClockServer** command accepts multiple server addresses in IPv4, IPv6, or Domain Name System (DNS) name formats. When multiple NTP server addresses are passed, **tsClockServer** sets the first obtainable address as the active NTP server. The rest are stored as backup servers that can take over if the active NTP server fails. The principal or primary FCS switch synchronizes its time with the NTP server every 64 seconds.

1. Connect to the switch and log in using an account assigned to the admin role.
2. Enter the **tsClockServer** command.

```
switch:admin> tsclockserver ntp1;ntp2
```

In this syntax, *ntp1* is the IP address or DNS name of the first NTP server, which the switch must be able to access. The second variable, *ntp2*, is the second NTP server and is optional. The operand "*ntp1;ntp2*" is optional; by default, this value is LOCL, which uses the local clock of the principal or primary FCS switch as the clock server.

The following example sets the NTP server.

```
switch:admin> tsclockserver
LOCL
switch:admin> tsclockserver "10.1.2.3"
```

The following example displays the NTP server.

```
switch:admin> tsclockserver
10.1.2.3
```

The following example sets up more than one NTP server using a DNS name.

```
switch:admin> tsclockserver "10.1.2.4;10.1.2.5;ntp.localdomain.net"
Updating Clock Server configuration...done.
Updated with the NTP servers
```

Changes to the clock server value on the principal or primary FCS switch are propagated to all switches in the fabric.

## NTP configuration distribution to Access Gateways

A switch running Fabric OS 7.4.0 or subsequent release can distribute the NTP server configuration to Access Gateways devices connected to the fabric. However, AG devices cannot distribute the NTP configuration to other switches in the fabric.



In switch mode, the principal or primary FCS switch synchronizes its time with the external NTP server every 64 seconds and sends time updates to other switches in the fabric. The time updates are not sent in-band to AG devices. An AG device need not sync with the external NTP server as it can receive NTP server configuration from the connected FOS switch. If the AG device is connected to more than one fabric, the latest clock server request received is configured.

Consider the following points when distributing the NTP server configuration:

- The **tsClockServer** command distributes the NTP server configuration to all switches within the fabric and AG devices connected to the same fabric.
- Already distributed NTP server configurations will persist on the AG device after firmware downgrade from Fabric OS 8.0.1 to a prior version on supported platforms.

## Domain IDs

Although domain IDs are assigned dynamically when a switch is enabled, you can change them manually so that you can control the ID number or resolve a domain ID conflict when you merge fabrics.

If a switch has a domain ID when it is enabled, and that domain ID conflicts with another switch in the fabric, the conflict is automatically resolved if the other switch's domain ID is not persistently set. The process can take several seconds, during which time traffic is delayed. If both switches have their domain IDs persistently set, one of them needs to have its domain ID changed to a domain ID not used within the fabric.

Prior to Fabric OS 7.4.0, the default domain ID for Brocade switches was 1.

Starting with Fabric OS 7.4.0, the xlate domain ID (XD) or front domain ID (FD) for an FC Router is assigned in the following ranges, if the insistent domain ID is not configured.

- The FD range for an FC Router is 160 through 199. The default front domain ID requested by an FC Router is 160.
- The XD range for an FC Router is 200 through 239. The default xlate domain ID requested by an FC Router is 200.

### NOTE

If there is no free domain ID available in the specified range for XD or FD, the principal switch assigns the lowest available domain ID starting from 1. The principal switch must be running Fabric OS 7.4.0 or later.

The principal switch overrides the specified domain ID range if the following conditions are true:

- If the insistent domain ID is configured for FD or XD
- The requested domain ID is not in the specified range
- The requested domain ID is available for domain ID assignment

When a switch, other than the FC Router FD or XD, requests a domain ID within the new specified range for the FC Router FD or XD, the principal switch assigns the domain ID, if it is available.

### NOTE

It is recommended that the Insistent Domain ID be configured when deploying features that rely on domain IDs, such as [D, I] Zoning, and TI Zoning.

## Domain ID issues

Keep the following restrictions in mind when working with domain IDs.

- Do not use domain ID 0. Using this domain ID can cause the switch to reboot continuously.
- Avoid changing the domain ID on the FCS switch in secure mode.
- To minimize downtime, change the domain IDs on the other switches in the fabric.

## Displaying the domain IDs

Use the following procedure to display device domain IDs:

1. Connect to the switch and log in using an account assigned to the admin role.
2. Enter the **fabricShow** command.

The following is an example of output of fabric information, including the domain ID (D\_ID)

The principal switch is determined by the arrow ( > ) next to the name of the switch.

```
switch:admin> fabricshow
```

Switch ID	Worldwide Name	Enet IP Addr	FC IP Addr	Name
2: fffc02	10:00:00:60:69:e0:01:46	10.3.220.1	0.0.0.0	"ras001"
3: fffc03	10:00:00:60:69:e0:01:47	10.3.220.2	0.0.0.0	"ras002"
5: fffc05	10:00:00:05:1e:34:01:bd fec0:60:69bc:63:205:1eff:fe34:1bd	10.3.220.5	0.0.0.0	"ras005"
6: fffc06	10:00:00:05:1e:34:02:3e	10.3.220.6	0.0.0.0	>"ras006"
7: fffc07	10:00:00:05:1e:34:02:0c	10.3.220.7	0.0.0.0	"ras007"

(output truncated)  
The Fabric has 26 switches

The following table displays the **fabricShow** fields.

**TABLE 3** fabricShow fields

Field	Description
Switch ID	The switch domain_ID and embedded port D_ID. The numbers are broken down as shown in the following example: <b>64: fffc40</b> 64 is the switch domain_ID fffc40 is the hexadecimal format of the embedded port D_ID.
World Wide Name	The switch WWN.
Enet IP Addr	The switch Ethernet IP address for IPv4- and IPv6-configured switches. For IPv6 switches, only the static IP address displays.
FC IP Addr	The switch Fibre Channel IP address.
Name	The switch symbolic or user-created name in quotes.

## Setting the domain ID

Use the following procedure to set the domain ID:

1. Connect to the switch and log in on an account assigned to the admin role.
2. Enter the **switchDisable** command to disable the switch.
3. Enter the **configure** command.
4. Enter **y** after the **Fabric Parameters** prompt.

```
Fabric parameters (yes, y, no, n): [no] y
```

5. Enter a unique domain ID at the **Domain** prompt. Use a domain ID value from 1 through 239 for normal operating mode (FCSW-compatible).

```
Domain: (1..239) [1] 3
```

6. Respond to the remaining prompts, or press **Ctrl-D** to accept the other settings and exit.
7. Enter the **switchEnable** command to re-enable the switch.

## Switch names

Switches can be identified by IP address, domain ID, World Wide Name (WWN), or by customized switch names that are unique and meaningful.

The following considerations apply to switch naming:

- Switch names can be from 1 through 30 characters long.
- All switch names must begin with a letter or number, and can contain letters, numbers, hyphen, or the underscore character.
- Switch names must be unique across logical switches.
- Changing the switch name causes a domain address format RSCN to be issued and may be disruptive to the fabric.

## Customizing the switch name

1. Connect to the switch and log in using an account assigned to the admin role.
2. Enter the **switchName** command and enter a new name for the switch.

```
switch:admin> switchname newname
```

The prompt does not change to the new switch name until AFTER you re-login.

3. Record the new switch name for future reference.

```
switch:FID128:# admin> switchname myswitch
Committing configuration...
Done.
Switch name has been changed.Please re-login into the switch for the change to be applied.
switch:FID128:# admin>
```

## Chassis names

Brocade recommends that you customize the chassis name for each platform. Some system logs identify devices by platform names; if you assign meaningful platform names, logs are more useful. All chassis names supported by Fabric OS v7.0.0 and later allow 31 characters. Chassis names must begin with an alphabetic character and can include alphabetic and numeric characters, and the underscore ( \_ ).

## Customizing chassis names

Use the following procedure to customize the chassis name:

1. Connect to the switch and log in using an account assigned to the admin role.
2. Enter the **chassisName** command.

```
ecp:admin> chassisname newname
```

3. Record the new chassis name for future reference.

## Fabric name

You can assign an alphanumeric name to identify and manage a logical fabric that formerly could only be identified by a fabric ID. The fabric name does not replace the fabric ID or its usage. The fabric continues to have a fabric ID, in addition to the assigned alphanumeric fabric name.

The following considerations apply to fabric naming:

- Each name must be unique for each logical switch within a chassis; duplicate fabric names are not allowed.
- A fabric name can be from 1 through 128 alphanumeric characters (a–z, 0–9).
- All switches in a logical fabric must be running Fabric OS v7.2.0 or later. Switches running earlier versions of the firmware can coexist in the fabric, but do not show the fabric name details.
- You must have admin permissions to configure the fabric name.

## Configuring the fabric name

To set and display the fabric name, use the **fabricName** command as shown here:

```
switch:user> fabricname --set myfabric@1
```

Using the **fabricName --set** command without a fabric name takes the existing fabric name and synchronizes it across the entire fabric. An error message displays if no name is configured.

To set a fabric name that includes spaces, enclose the fabric name in quotes, as shown here:

```
switch:user> fabricname --set "my new fabric"
```

To set a fabric name that includes bash special meta-characters or spaces, use the command **fabricName** as shown in the following example:

```
switch:user> fabricname --set 'red fabric $$'
```

To clear the fabric name, use the **fabricName --clear** command.

## High availability considerations for fabric names

Fabric names locally configured or obtained from a remote switch are saved in the configuration database, and then synchronized to the standby CP on dual-CP-based systems.

## Upgrade and downgrade considerations for fabric names

Fabric names are lost during a firmware downgrade. No default fabric name is provided. If a fabric name is needed, it must be configured after the upgrade.

## Switch activation and deactivation

By default, the switch is enabled after power is applied and diagnostics and switch initialization routines have finished. You can disable and re-enable the switch as necessary.

When you enable or disable a switch, the affected ports depend on whether Virtual Fabrics is enabled. The following table describes which ports are affected for each type of enable or disable operation.

**TABLE 4** Ports affected when you enable or disable a switch in VF or non-VF mode

Operation	Virtual Fabrics enabled	Virtual Fabrics not enabled
Enable switch	Enables all ports on logical switch	Enables all ports on physical chassis
Enable chassis	Enables all ports on physical chassis	Not allowed
Disable switch	Disables all ports on logical switch	Disables all ports on physical chassis
Disable chassis	Disables all ports on physical chassis	Not allowed

## Disabling a switch

You must disable a switch before making configuration changes or before running offline diagnostic tests.

1. Connect to the switch and log in using an account assigned to the admin role.
2. Enter the **switchDisable** command.

```
switch:admin> switchdisable
```

All Fibre Channel ports on the switch are taken offline. If the switch is part of a fabric, the fabric is reconfigured.

If Virtual Fabrics is enabled, only the ports allocated to the logical switch are disabled. To disable all of the ports, you must disable the entire chassis.

## Enabling a switch

The switch is enabled by default after it is powered on and switch initialization routines have finished. You must re-enable the switch after making configuration changes or running offline diagnostics.

1. Connect to the switch and log in using an account assigned to the admin role.
2. Enter the **switchEnable** command.

```
switch:admin> switcheenable
```

All Fibre Channel ports that passed Power On Self Test (POST) are enabled. If the switch has inter-switch links (ISLs) to a fabric, it joins the fabric.

If Virtual Fabrics is enabled, only the ports allocated to the logical switch are enabled. To enable all of the ports, you must enable the entire chassis.

## Disabling a chassis

Disabling a chassis disables all Fibre Channel ports on all logical switches in the chassis. You must disable a chassis before making chassis-wide configuration changes or before running offline diagnostic tests.

1. Connect to any logical switch in the chassis and log in using an account assigned to the admin role.
2. Enter the **chassisDisable** command.

```
switch:FID128:admin> chassisdisable
```

```
This command can cause disruption to multiple logical switches.
Are you sure you want to disable all chassis ports now? (yes, y, no, n): [no]y
switch:FID128:admin>
```

All Fibre Channel ports on all logical switches are taken offline. If the logical switches are in fabrics, the fabrics are reconfigured.

**NOTE**

After a **chassisDisable** , if you want to do an **haFailover** , you should wait at least 30 seconds.

## Enabling a chassis

Enabling a chassis enables all Fibre Channel ports on all logical switches in the chassis. The chassis is enabled by default after it is powered on and switch initialization routines have finished. You must re-enable the chassis after making fabric-wide configuration changes or running offline diagnostics.

1. Connect to the switch and log in using an account assigned to the admin role.
2. Enter the **chassisEnable** command.

```
switch:FID128:admin> chassisenable
```

For all logical switches in the chassis, all Fibre Channel ports are enabled. If any of the logical switches have inter-switch links (ISLs) to a fabric, it joins the fabric.

## Device shutdown

To avoid corrupting your file system, you must perform graceful shutdowns of Brocade switches, Backbones, and Directors by using the following instructions.

### Powering off a Brocade switch

Use the following procedure to gracefully shut down a Brocade switch.

1. Connect to the switch and log in using an account assigned to the admin role.
2. Enter the **sysShutdown** command.
3. Enter **y** at the prompt.

```
switch:admin> sysshutdown
```

```
This command will shutdown the operating systems on your switch.
You are required to power-cycle the switch in order to restore operation.
Are you sure you want to shutdown the switch [y/n]?y
```

4. Wait until the following message displays:

```
Broadcast message from root (ttyS0) Wed Jan 25 16:12:09 2006...
The system is going down for system halt NOW !!
INIT: Switching to runlevel: 0
INIT: Sending processes the TERM signal
Unmounting all filesystems.
The system is halted
flushing ide devices: hda
Power down.
```

5. Power off the switch.

### Powering off a Brocade Director

Use the following procedure to power off a Brocade DCX 8510 and X6 Directors:

1. From the active CP in a dual-CP platform, enter the **sysShutdown** command.

**NOTE**

When the **sysShutdown** command is issued on the active CP, the active CP, the standby CP, and any application blades are all shut down.

2. Enter **y** at the prompt.
3. Wait until the following message displays:

```
DCX:FID128:admin> sysshutdown

This command will shutdown the operating systems on your switch.
You are required to power-cycle the switch in order to restore operation.
Are you sure you want to shutdown the switch [y/n]?y
HA is disabled
Stopping blade 10
Shutting down the blade....
Stopping blade 12
Shutting down the blade....
Broadcast message from root (pts/0) Fri Oct 10 08:36:48 2008...
The system is going down for system halt NOW !!
```

4. Power off the switch.

## Basic connections

Before connecting a switch to a fabric that contains switches running different firmware versions, you must first set the same port identification (PID) format on all switches. The presence of different PID formats in a fabric causes fabric segmentation.

- For information on PID formats and related procedures, refer to [Performing Advanced Configuration Tasks](#) on page 69.
- For information on configuring the routing of connections, refer to [Routing Traffic](#) on page 107.
- For information on configuring extended inter-switch connections, refer to [Managing Long-Distance Fabrics](#) on page 483.

## Device connection

To minimize port logins, power off all devices before connecting them to the switch. When powering the devices back on, wait for each device to complete the fabric login before powering on the next one.

For devices that cannot be powered off, first use the **portDisable** command to disable the port on the switch, connect the device, and then use the **portEnable** command to enable the port.

## Switch connection

See the hardware reference manual of your specific switch for ISL connection and cable management information. The standard or default ISL mode is LO. ISL mode LO is a static mode, with the following maximum ISL distances:

- 10 km at 1 Gbps
- 5 km at 2 Gbps
- 2.5 km at 4 Gbps
- 1 km at 8 Gbps
- 1 km at 10 Gbps
- 625 m at 16 Gbps
- 150 m at 32 Gbps

For more information on extended ISL modes, which enable long distance inter-switch links, refer to [Managing Long-Distance Fabrics](#) on page 483.





# Performing Advanced Configuration Tasks

• Port identifiers (PIDs) and PID binding overview.....	69
• Ports.....	73
• Blade terminology and compatibility.....	87
• Enabling and disabling blades.....	89
• Blade swapping.....	90
• Disabling switches.....	95
• Power management.....	95
• Equipment status.....	96
• Audit log configuration.....	97
• Duplicate PWWN handling during device login.....	101
• Forward error correction.....	103

## Port identifiers (PIDs) and PID binding overview

Port identifiers (PIDs, also called *Fabric Addresses*) are used by the routing and zoning services in Fibre Channel fabrics to identify ports in the network.

All devices in a fabric must use the same PID format. When you add new equipment to the SAN, you may need to change the PID format on legacy equipment.

Many scenarios cause a device to receive a new PID; for example, unplugging the device from one port and plugging it into a different port as part of fabric maintenance, or changing the domain ID of a switch, which might be necessary when merging fabrics, or changing compatibility mode settings.

Some device drivers use the PID to map logical disk drives to physical Fibre Channel counterparts. Most drivers can either change PID mappings dynamically, also called *dynamic PID binding*, or use the WWN of the Fibre Channel disk for mapping, also called *WWN binding*.

Some older device drivers behave as if a PID uniquely identifies a device; they use *static PID binding*. These device drivers should be updated, if possible, to use WWN binding or dynamic PID binding instead, because static PID binding creates problems in many routine maintenance scenarios. Fortunately, very few device drivers still behave this way. Many current device drivers enable you to select static PID binding as well as WWN binding. You should only select static PID binding if there is a compelling reason, and only after you have evaluated the effect of doing so.

## Core PID addressing mode

Core PID is the default PID format for Brocade platforms. It uses the entire 24-bit address space of the domain, area ID, and AL\_PA to determine an object's address within the fabric.

The Core PID is a 24-bit address built from the following three 8-bit fields:

- Domain ID, written in hex and the numeric range is from 01 through ee (1 through 239)
- Area ID, written in hex and the numeric range is from 01 through ff (1 through 255)
- AL\_PA

For example, if a device is assigned an address of 0f1e00, the following would apply:

- 0f is the domain ID.
- 1e is the area ID.

- 00 is the assigned AL\_PA.

From this information, you can determine which switch the device resides on from the domain ID, which port the device is attached to from the area ID, and if this device is part of a loop from the AL\_PA number.

## Fixed addressing mode

With fixed addressing mode, each port has a fixed address assigned by the system based on the port number.

This address does not change unless you choose to swap the address using the **portSwap** command.

Fixed addressing mode is the default addressing mode used in all platforms that do not have Virtual Fabrics enabled. When Virtual Fabrics is enabled on the Brocade Backbone, fixed addressing mode is used only on the default logical switch.

## 10-bit addressing (mode 0)

The 10-bit addressing mode is the default mode for all the logical switches. This addressing scheme is flexible to support a large number of F\_Ports. In the regular 10-bit addressing mode, the **portAddress --auto** command supports addresses from 0x00 to 0x8F.

### NOTE

The default switch in the Brocade Backbones uses the fixed addressing mode.

The 10-bit addressing mode utilizes the 8-bit area ID and the borrowed upper two bits from the AL\_PA portion of the PID. Areas 0x00 through 0x8F use only 8 bits for the port address and support up to 256 NPIV devices. A logical switch can support up to 144 ports that can each support 256 devices. Areas 0x90 through 0xFF use an additional two bits from the AL\_PA for the port address. Therefore, these ports support only 64 NPIV devices per port.

10-bit addressing mode provides the following features:

- A PID is dynamically allocated only when the port is first moved to a logical switch and thereafter it is persistently maintained.
- PIDs are assigned in each logical switch starting with 0xFFC0, and can go to 0x8000 in the case of 64-port blades.
- Shared area limitations are removed on 48-port and 64-port blades.
- Any port on a 48-port or 64-port blade can support up to 256 NPIV devices (in fixed addressing mode, only 128 NPIV devices are supported in non-VF mode and 64 NPIV devices in VF mode on a 48-port blade).
- Any port on a 48-port blade can support loop devices.
- Any port on a 48-port or 64-port blade can support hard port zoning.
- Port index is not guaranteed to be equal to the port area ID.

## 256-area addressing (mode 1 and mode 2)

The 256-area addressing mode is available only in a logical switch on the Brocade Backbone. In this mode, only 256 ports are supported and each port receives a unique 8-bit area address. This mode can be used in FICON environments, which have strict requirements for 8-bit area FC addresses.

There are two types of area assignment modes with 256-area addressing: zero-based and port-based.

### ATTENTION

On default logical switches with an address mode other than mode 1, any 48-port and 64-port blades are disabled if FICON Management Server (FMS) is enabled.

Refer to the *FICON Administrator's Guide* for additional details.

## Zero-based addressing (mode 1)

With zero-based addressing, unique area assignments begin at zero regardless of where the port is physically located. This allows FICON users to make use of high port count blades with port indexes greater than 256.

Zero-based addressing assigns areas when the ports are added to the logical switch, beginning at area 0x00. When a port is assigned to a logical switch, the next free PID starting from 0x00 is assigned. This mode allows FICON customers to make use of the upper ports of a 48-port or 64-port blade.

Zero-based mode is supported on the default switch.

## Port-based addressing (mode 2)

With port-based addressing, unique area assignments are based on the port index.

Port-based addressing mode does not allow FICON users to make use of ports with an index greater than 256 (high ports of a high port count blade), but this mode is compatible with domain-index zoning.

Port-based addressing is not supported on the default switch.

The 48-port and 64-port blades have the following restrictions:

- Port-based addressing is not supported on the upper 16 ports of a 64-port blade on the DCX 8510-4 Backbones.
- Port-based addressing is not supported on the 48-port blades in the Brocade DCX 8510-8 Backbones. Only zero-based addressing is supported on these blades.

## WWN-based PID assignment

WWN-based PID assignment is disabled by default. When the feature is enabled, bindings are created dynamically; as new devices log in, they automatically enter the WWN-based PID database. The bindings exist until you explicitly unbind the mappings through the CLI or change to a different addressing mode. If there are any existing devices when you enable the feature, you must manually enter the WWN-based PID assignments through the CLI.

This feature also allows you to configure a PID persistently using a device WWN. When the device logs in to the switch, the PID is bound to the device WWN. If the device is moved to another port in the same switch, or a new blade is hot-plugged, the device receives the same PID (area) at its next login.

Once WWN-based PID assignment is enabled, you must manually enter the WWN-based PID assignments through the CLI for any existing devices.

### NOTE

When the WWN-based PID assignment feature is enabled, area assignment is dynamic and has no predetermined order or precedence. This means that on the first fabric login of a PID, the PID will be assigned the next available WWN area and it will remain mapped to that WWN after that point (including subsequent logins). Static WWN-area bindings are preserved, but are not used for dynamic assignments.

PID assignments are supported for a maximum of 4096 devices; this includes both point-to-point and NPIV devices. The number of point-to-point devices supported depends on the areas available. For example, 448 areas are available on Backbones and 256 areas are available on switches. When the number of entries in the WWN-based PID database reaches 4096 areas used up, the oldest unused entry is purged from the database to free up the reserved area for the new FLOGI.

## Virtual Fabrics considerations for WWN-based PID assignment

WWN-based PID assignment is disabled by default and is supported in the default switch on the Brocade DCX 8510 Backbones and X6 Directors. This feature is not supported on the FX8-24 and SX6 blades. The total number of ports in the default switch must be 256 or less.

When the WWN-based PID assignment feature is enabled and a new blade is plugged into the chassis, the ports for which the area is not available are disabled.

## NPIV

If any N\_Port ID Virtualization (NPIV) devices have static PIDs configured and the acquired area is not the same as the one being requested, the FDISC coming from that device is rejected and the error is noted in the RASlog.

If the NPIV device has Dynamic Persistent PID set, the same AL\_PA value in the PID is used. This guarantees NPIV devices get the same PID across reboots and AL\_PAs assigned for the device do not depend on the order in which the devices come up. For more information on NPIV, refer to [NPIV](#) on page 437.

## Enabling automatic PID assignment

### NOTE

To activate the WWN-based PID assignment, you do not need to disable the switch.

Use the following procedure to enable automatic PID assignment.

1. Connect to the switch and log in using an account with admin permissions.
2. Enter the **configure** command.
3. At the **Fabric parameters** prompt, type **y**.
4. At the **WWN Based persistent PID** prompt, type **y**.
5. Press **Enter** to bypass the remaining prompts without changing them.

## Example of activating PID assignments

```
switch: admin> configure

Configure...
Fabric parameters (yes, y, no, n): [no] y
WWN Based persistent PID (yes, y, no, n): [no] y

System services (yes, y, no, n): [no]
ssl attributes (yes, y, no, n): [no]
rpcd attributes (yes, y, no, n): [no]
cfgload attributes (yes, y, no, n): [no]
webtools attributes (yes, y, no, n): [no]
Custom attributes (yes, y, no, n): [no]
system attributes (yes, y, no, n): [no]
```

## Assigning a static PID

Use the following procedure to assign a static PID.

1. Connect to the switch and log in using an account with admin permissions.
2. Enter the **wwnAddress -bind** command to assign a 16-bit PID to a given WWN.

## Clearing PID binding

Use the following procedure to clear a PID binding.

1. Connect to the switch and log in using an account with admin permissions.
2. Enter the **wwnAddress -unbind** command to clear the PID binding for the specified WWN.

## Showing PID assignments

Use the following procedure to display PID assignments.

1. Connect to the switch and log in using an account with admin permissions.
2. Based on what you want to display, enter the appropriate command.
  - To display the assigned WWN-PID bindings, enter the following:  
**wwnAddress --show**
  - To display the PID assigned to the specific device WWN, enter the following:  
**wwnAddress -findPID *wwn***

## Ports

Ports provide either a physical or virtual network connection point for a device. Brocade devices support a wide variety of ports.

### Port Types

The following is a list of port types that may be part of a Brocade device:

- **D\_Port** -- A diagnostic port lets an administrator isolate the link to diagnose link-level faults. This port runs only specific diagnostics tests and does not carry any fabric traffic. Refer to [Diagnostic Port](#) on page 415 for more information on this port type.
- **E\_Port** -- An expansion port that is assigned to ISL links to expand a fabric by connecting it to other switches. Two connected E\_Ports form an inter-switch link (ISL). When E\_Ports are used to connect switches, those switches merge into a single fabric without an isolation demarcation point. ISLs are non-routed links.
- **EX\_Port** -- A type of E\_Port that connects a Fibre Channel router to an edge fabric. From the point of view of a switch in an edge fabric, an EX\_Port appears as a normal E\_Port. It follows applicable Fibre Channel standards as other E\_Ports. However, the router terminates EX\_Ports rather than allowing different fabrics to merge as would happen on a switch with regular E\_Ports. An EX\_Port cannot be connected to another EX\_Port.
- **F\_Port** -- A fabric port that is assigned to fabric-capable devices, such as SAN storage devices.
- **G\_Port** -- A generic port that acts as a transition port for non-loop fabric-capable devices.
- **L\_Port** or **FL\_Port** -- A loop or fabric loop port that connects loop devices. L\_Ports are associated with private loop devices and FL\_Ports are associated with public loop devices.
- **U\_Port** -- A universal Fibre Channel port. This is the base Fibre Channel port type, and all unidentified or uninitiated ports are listed as U\_Ports.
- **VE\_Port** -- A virtual E\_Port that is a gigabit Ethernet switch port configured for an FCIP tunnel.
- **VEX\_Port** -- A virtual EX\_Port that connects a Fibre Channel router to an edge fabric. From the point of view of a switch in an edge fabric, a VEX\_Port appears as a normal VE\_Port. It follows the same Fibre Channel protocol as other VE\_Ports. However, the router terminates VEX\_Ports rather than allowing different fabrics to merge as would happen on a switch with regular VE\_Ports.

## Director port blades

Because DCX 8510 and X6 Directors contain interchangeable port blades, their procedures differ from those for fixed-port switches. For example, fixed-port models identify ports only by the port number, while Backbones identify ports by *slot/port* notation

**NOTE**

For detailed information about the Brocade DCX 8510 and X6 Director families, refer to the respective hardware reference manuals.

The different blades that can be inserted into a chassis are described as follows:

- Control processor (CP) blades contain communication ports for system management, and are used for low-level, platform-wide tasks.
- Core blades are used for intra-chassis switching as well as interconnecting two Directors.
- Port blades are used for host, storage, and interswitch connections.
- Application (AP) blades are used for Extension (FCIP and IP) support.

**NOTE**

On each port blade, a particular port must be represented by both slot number and port number.

The Brocade DCX 8510-8 has 12 slots that contain control processor, core, port, and AP blades:

- Slot numbers 6 and 7 contain CPs.
- Slot numbers 5 and 8 contain core blades.
- Slot numbers 1 through 4 and 9 through 12 contain port and AP blades.

The Brocade DCX 8510-4 has 8 slots that contain control processor, core, port, and AP blades:

- Slot numbers 4 and 5 contain CPs.
- Slot numbers 3 and 6 contain core blades.
- Slot numbers 1 and 2, and 7 and 8 contain port and AP blades.

The Brocade X6-8 has 12 slots that contain control processor, core, port, and AP blades:

- Slot numbers 1 and 2 contain CPs.
- Slot numbers 7 and 8 contain core blades.
- Slot numbers 3 through 6 and 9 through 12 contain port and AP blades.

The Brocade X6-4 has 8 slots that contain control processor, core, port, and AP blades:

- Slot numbers 1 and 2 contain CPs.
- Slot numbers 5 and 6 contain core blades.
- Slot numbers 3 and 4, and 7 and 8 contain port and AP blades.

When you have port blades with different port counts in the same Backbones or Directors, (for example, 32-port blades and 48-port blades, or 48-port blades and 64-port blades), the area IDs no longer match the port numbers. [Table 6](#) on page 88 lists the port numbering schemes for the blades.

## Setting port names

Perform the following steps to specify a port name. For Backbones, specify the slot number where the blade is installed.

1. Connect to the switch and log in using an account with admin permissions.
2. Enter the **portName** command.

```
switch:admin> portname 1/0 -n trunk1
```

## Port identification by slot and port number

The port number is a number assigned to an external port to give it a unique identifier in a switch.

To select a specific port in the Backbones, you must identify both the slot number and the port number using the format *slot number/port number*. No spaces are allowed between the slot number, the slash (/), and the port number.

### Example of enabling port 4 on a blade in slot 2

```
switch:admin> portenable 2/4
```

## Port identification by port area ID

The relationship between the port number and area ID depends upon the PID format used in the fabric. When Core PID format is in effect, the area ID for port 0 is 0, for port 1 is 1, and so forth.

For 32-port blades (FC16-32), the numbering is contiguous up to port 15; from port 16, the numbering is still contiguous, but starts with 128. For example, port 15 in slot 1 has a port number and area ID of 15; port 16 has a port number and area ID of 128; port 17 has a port number and area ID of 129.

For 48-port blades (FC16-48, FC32-48), the numbering is the same as for 32-port blades for the first 32 ports on the blade. For ports 32 through 47, area IDs are not unique and port index should be used instead of area ID.

For the 64-port blades (FC16-64), the numbering is the same as for 32-port blades for the first 32 ports on the blade. For ports 32 through 63, area IDs are not unique and port index should be used instead of area ID.

If you perform a port swap operation, the port number and area ID no longer match.

To determine the area ID of a particular port, enter the **switchShow** command. This command displays all ports on the current (logical) switch and their corresponding area IDs.

## Port identification by index

With the introduction of 48-port and 64-port blades, indexing was introduced. Unique area IDs are possible for up to 255 areas, but beyond that there needed to be some way to ensure uniqueness.

A number of fabric-wide databases supported by Fabric OS (including ZoneDB, and the ACL DCC) allow a port to be designated by the use of a "D,P" (*domain,port*) notation. While the "P" component appears to be the port number, for up to 255 ports it is actually the *area* assigned to that port.

### NOTE

The port area schema does not apply to the Brocade DCX 8510-4 and X6-4 Backbones.

## Dynamic Portname

When the Dynamic Portname feature is enabled, the port name can be dynamically populated with a few default fields.

This feature simplifies the switch configuration and quickly associates ports to the switch or device. This feature dynamically populates the port name with various fields, such as switch name, port type, port index and alias name.

The Dynamic Portname feature is disabled by default and can be enabled using the **configure** command.

The FDMI Host Name feature and the Dynamic Portname feature are mutually exclusive. If you try to enable the Dynamic Portname feature along with the FDMI Host Name feature, then the **configure** command fails and exits with an error message. You can configure the Dynamic Portname feature when the switch is online. The switch need not be offline to configure the Dynamic Portname feature.

The Dynamic Portname feature is not supported on a switch if AG mode is enabled. The Dynamic Portname feature is not supported in FMS mode.

MAPS rules and alerts use the dynamically populated port name to report the thresholds.

The port name field for E\_Ports and F\_Ports displays the following information:

- Switch name, port type, and port index as part of the port name for E\_Ports
- Switch name, port type, port index, and alias name as part of the port name for F\_Ports

When displaying the port name of an F\_Port assigned with multiple aliases, the following order of preferences is used to pick the alias name.

1. Alias with one member in the WWN format
2. Alias with one member in the D,I format
3. Alias with multiple members in the WWN format
4. Alias with multiple members in the D,I format



## Example to configure the Dynamic Portname feature

The **configure** command is used to configure the Dynamic Portname. The option to configure the Dynamic Portname appears under Fabric parameters.

```
switch:admin> configure

Configure...

Fabric parameters (yes, y, no, n): [no] yes
  WWN Based persistent PID (yes, y, no, n): [no]
  Location ID: (0..4) [0]
  Dynamic Portname (on, off): [off] on
  Edge Hold Time(Low(80ms), Medium(220ms), High(500ms), UserDefined(80-500ms): (80..500) [220]
  Remote Fosexec feature: (on, off): [on]
  High Integrity Fabric Mode (yes, y, no, n): [no]
D-Port Parameters (yes, y, no, n): [no]
RDP Polling Cycle(hours)[0 = Disable Polling]: (0..24) [0]
System services (yes, y, no, n): [no]
ssl attributes (yes, y, no, n): [no]
rpcd attributes (yes, y, no, n): [no]
cfgload attributes (yes, y, no, n): [no]
webtools attributes (yes, y, no, n): [no]
```

This example shows that the FDMI Host Name and Dynamic Portname features are mutually exclusive. If you try to enable Dynamic Portname feature along with FDMI Host Name feature, the **configure** command fails and exits with an error message.

```
switch:admin> configure

Configure...

Fabric parameters (yes, y, no, n): [no] yes

  Domain: (1..239) [1]
  WWN Based persistent PID (yes, y, no, n): [no]
  F-Port Device Update Mode: (on, off): [on]
  Allow XISL Use (yes, y, no, n): [yes]
  R_A_TOV: (4000..120000) [10000]
  E_D_TOV: (1000..5000) [2000]
  WAN_TOV: (0..30000) [0]    MAX_HOPS: (7..19) [7]
  Data field size: (256..2112) [2112]
  Sequence Level Switching: (0..1) [0]
  Disable Device Probing: (0..1) [0]
  Suppress Class F Traffic: (0..1) [0]
  Per-frame Route Priority: (0..1) [0]
  Long Distance Fabric: (0..1) [0]
  BB credit: (1..27) [16]
  Disable FID Check (yes, y, no, n): [no]
  Insistent Domain ID Mode (yes, y, no, n): [no]
  Disable Default PortName (yes, y, no, n): [no]
  Display FDMI Host Name (yes, y, no, n): [yes]
  Dynamic Portname (on, off): [off] on

Error: "Dynamic Portname" and "Display FDMI Host Name" are mutually exclusive.
Please set "Display FDMI Host Name" to "no" to enable "Dynamic Portname".
```

### Example to show the portname output

The **portname** command displays the switch name, port type, port index, and alias in the output. *none* indicates the error in alias name and *null* indicates that the alias is not present.

```
switch:admin> portname
port 0: EDGE1_sw76.E_PORT.0
port 1: EDGE1_sw76..1
port 2: EDGE1_sw76..2
port 3: EDGE1_sw76..3
port 4: EDGE1_sw76..4
port 5: EDGE1_sw76..5
port 6: EDGE1_sw76.F_PORT.6.emlx
port 7: EDGE1_sw76.F_PORT.7.
port 8: EDGE1_sw76.F_PORT.8.
```

### Example to show the portshow output

The **portshow** command displays the switch name, port type, port index, and alias in the output.

```
switch:admin> portshow 28
portIndex: 28
portName: sw78.E_PORT.28
portHealth: HEALTHY

Authentication: None
portDisableReason: None
portCFlags: 0x1
portFlags: 0x1000090b    PRESENT ACTIVE E_PORT T_PORT T_MASTER G_PORT U_PORT LOGICAL_ONLINE LOGIN
LocalSwcFlags: 0x0
portType: 18.0
POD Port: Port is licensed
portState: 1    Online
Protocol: FC
portPhys: 6    In_Sync    portScn: 16    E_Port    Trunk master port Flow control mode 4
port generation number: 0
state transition count: 1
[output truncated]
```

## Example to show the switchshow output

The **switchshow -portname** command displays the switch name, port type, port index, and alias in the output.

```
switch:admin> switchshow -portname

switchName:    sw0
switchType:    66.1
switchState:   Online
switchMode:    Native
switchRole:    Principal
switchDomain:   1
switchId:      fffc01
switchWwn:     10:00:00:05:1e:82:3c:2a
zoning:        OFF
switchBeacon:  OFF
FC Router:     OFF
Fabric Name:   switch_test
Allow XISL Use: OFF
LS Attributes: [FID: 128, Base Switch: No, Default Switch: Yes, Address Mode 0]
```

Index	Port	PortWWN	Name
0	0	20:00:00:05:1e:82:3c:2a	port0
1	1	20:01:00:05:1e:82:3c:2a	port1
2	2	20:02:00:05:1e:82:3c:2a	port2
3	3	20:03:00:05:1e:82:3c:2a	port3
4	4	20:04:00:05:1e:82:3c:2a	port4
5	5	20:05:00:05:1e:82:3c:2a	port5
6	6	20:06:00:05:1e:82:3c:2a	port6
7	7	20:07:00:05:1e:82:3c:2a	port7
8	8	20:08:00:05:1e:82:3c:2a	port8
9	9	20:09:00:05:1e:82:3c:2a	port9
10	10	20:0a:00:05:1e:82:3c:2a	port10
11	11	20:0b:00:05:1e:82:3c:2a	port11
12	12	20:0c:00:05:1e:82:3c:2a	port12
13	13	20:0d:00:05:1e:82:3c:2a	port13
14	14	20:0e:00:05:1e:82:3c:2a	port14

[output truncated]

## Dynamic port name format

You can configure the port name format for the dynamically populated port names. You can add or delete any fields from the supported list. At least one field should be given as input to set the dynamic port name format. Use the **portName** command with the "-d" option to configure the dynamic port name format. The dynamic port name format is a switch wide configuration and this format will be used for all the ports in the switch. The dynamic port name format is stored in the configuration.

The supported port name fields are Switch name, Port type, Port Index, slot number/port number, F\_Port Alias, FDMI hostname and Remote switch name. A control key is used to represent the supported port name fields. The dot ".", dash "-" and under score "\_" are the supported field separators. Only these control keys and field separators are allowed as inputs to set the dynamic port name format.

### NOTE

You can define the dynamic port name format even if the dynamic port name feature is not enabled. However, the customized dynamic port name format is displayed only if the dynamic port name feature is enabled.

### NOTE

You cannot downgrade to an earlier version than Fabric OS 8.0.1 when the dynamic port name format is set to a non default dynamic port name format using this dynamic port name format feature.

The following are the supported port name fields and their corresponding control keys:

Control key (case sensitive)	Port name field
S	Switch name
T	Port type
I	Port index
C	Slot number / port number
A	F-Port alias
F	FDML hostname
R	Remote switch name

Consider the following conditions while configuring the dynamic port name format.

- The default format string is "S.T.I.A" and the default field separator is dot ".".
- "S.T.I.A" represents <switchname>.<Port type>.<Port index>.<Alias name>
- The maximum number of characters can be 128. Exceeding characters are truncated.
- Only the Control Keys and supported separators are allowed in the format string, and the Control Keys are case sensitive.
- Dynamic port name format is not supported in AG and FMS modes.
- The format string should not start or end with field separators. For example, ".S.T.I.A."
- All field separators must be of same type. Multiple type field separators are not allowed in format string. For example, "S.T\_I-A".
- Consecutive field separators are not allowed. For example, "S..T..I..A".
- Consecutive control keys are not allowed. For example, "S.T.A".
- Repeated control keys are not allowed in the format string. For example, "S.T.S.I.T".
- The "C" and "I" control keys are mutually exclusive.
- At least one control key should be available to set the dynamic port name format.
- The fields without values will be left empty. For example, "my\_switch..246" for format string "S.T.I.A", while the port is offline.

The following is an example:

```
sw0:root> portname -d "S.T.I.R.A"
The dynamic port name format "S.T.I.R.A" is configured successfully

sw0:root> portname -d
"S.T.I.R.A"

sw0:root> portname
port 0: sw0..0..
port 1: sw0..1..
port 2: sw0..2..
port 3: sw0.E_PORT.3.pluto_218.
port 4: sw0..4..
port 5: sw0..5..
<snipped>
port 14: sw0..14..
port 15: sw0..15..
port 16: sw0.E_PORT.16.sw-46.
port 17: sw0.F_PORT.17..
port 18: sw0..18..
port 19: sw0.F_PORT.19..
port 20: sw0..20..
<snipped>
```

## Configuring a device-switch connection

For 8-Gbps platforms only: To configure an 8 Gbps (and 8 Gbps only) connection between a device and a switch, use the **portCfgFillWord** command.

The **portCfgFillWord** command provides the following configuration options:

- Mode Link Init/Fill Word
- Mode 0 IDLE/IDLE
- Mode 1 ARBF/ARBF
- Mode 2 IDLE/ARBF
- Mode 3 If ARBF/ARBF fails, use IDLE/ARBF

This command not applicable to Gen 5 (16-Gbps) and Gen 6 (32-Gbps) platforms.

### ATTENTION

Although this setting only affects devices logged in at 8 Gbps, changing the mode is disruptive regardless of the speed at which the port is operating.

The setting is retained and applied any time an 8 Gbps device logs in. Upgrades from prior releases which supported only Modes 0 and 1 will not change the existing setting, but switches reset to factory defaults with Fabric OS v6.3.1 or later will be configured to Mode 0 by default. The default setting on new units may vary by vendor.

Modes 2 and 3 are compliant with FC-FS-3 specifications (standards specify the IDLE/ARBF behavior of Mode 2, which is used by Mode 3 if ARBF/ARBF fails after three attempts). For most environments, Brocade recommends using Mode 3, as it provides more flexibility and compatibility with a wide range of devices. In the event that the default setting or Mode 3 does not work with a particular device, contact your switch vendor for further assistance.

## Swapping port area IDs

If a device that uses port binding is connected to a port that fails, you can use port swapping to make another physical port use the same PID as the failed port. The device can then be plugged into the new port without the need to reboot the device.

If two ports are changed using the **portSwap** command, their respective areas and "P" values are exchanged.

For ports that are numbered above 255, the "P" value is a logical index. The first 256 ports continue to have an index value equal to the area ID assigned to the port. If a switch is using Core PID format, and no port swapping has been done, the port index value for all ports is the same as the physical port numbers. Using **portSwap** on a pair of ports will exchange the area ID and index values of those ports.

Port swapping has the following restrictions:

- Shared area ports cannot be swapped.
- Ports that are part of a trunk group cannot be swapped.
- GbE ports cannot be swapped.
- Ports on a faulty blade cannot be swapped.
- Swapping ports between different logical switches is not supported. The ports on the source and destination blades must be in the same logical switch.
- The **portSwap** command is not supported for ports above 256.
- Port swapping is not supported when TI Zoning is in use.
- Port swapping is not supported on 48-port and 64-port blades.

Use the following procedure to swap the port area IDs of two physical switch ports. The swapped area IDs for the two ports remain persistent across reboots, power cycles, and failovers.

To swap port area IDs, the port swap feature must be enabled, and both switch ports must be disabled.

1. Connect to the switch and log in using an account with admin permissions.
2. Enter the **portSwapEnable** *port\_ID* command to enable the feature.
3. Enter the **portDisable** *port\_ID* command on each of the source and destination ports to be swapped.

The following example disables port 1 and port 1/2.

```
switch:admin> portdisable 1
switch:admin> portdisable 1/2
```

4. Enter the **portSwap** *port\_ID1 port\_ID2* command for the ports you want swapped.

The following example swaps port 1 and port 2.

```
switch:admin> portswap 1 2
switch:admin> portswap 1/1 2/2
```

5. Enter **portSwapShow** to verify that the port area IDs have been swapped.

A table is displayed, showing the physical port numbers and the logical area IDs for any swapped ports.

6. Enter **portSwapDisable** to disable the port swap feature.

## Enabling a port

By default, all licensed ports are enabled. You can disable and re-enable them as necessary.

Ports that you activate with the Ports on Demand license must be enabled explicitly, as described in the *Fabric OS Software Licensing Guide*.

1. Connect to the switch and log in using an account with admin permissions.
2. Enter the appropriate command based on the current state of the port and whether it is necessary to specify a slot number:
  - To enable a port that is disabled, enter the following command:

```
portEnable [slot / ]port
```

- To enable a port that is persistently disabled, enter the following command:

```
portCfgPersistentEnable [slot / ]port
```

In FMS mode, you cannot use the **portCfgPersistentEnable** command, so you must use the **portEnable** command instead.

If you change port configurations during a switch failover, the ports may become disabled. To bring the ports online, re-issue the **portEnable** command after the failover is complete.

### NOTE

You may also use the **portCfgPersistence** command while enabling or disable a port. For more information refer to the *Fabric OS Command Reference*.

## Disabling a port



### CAUTION

If you disable the last E\_Port or ISL connecting the switch to the fabric, the fabric reconfigures, the switch segments from the fabric, and all traffic flowing between the switch and the fabric is lost.

1. Connect to the switch and log in using an account with admin permissions.

2. Enter the appropriate command based on the current state of the port and whether it is necessary to specify a slot number:
  - To disable a port that is enabled, enter the **portDisable** command.
  - To disable a port that is persistently enabled, enter the **portCfgPersistentDisable** command.  
 In FMS mode, you cannot use the **portCfgPersistentDisable** command, so you must use the **portDisable** command instead.
  - To set a persistently disabled port to normal disabled without enabling the port first, enter the **portCfgPersistence --set -persistentenable** command.  
 In this case, the port becomes normal disabled and not persistently disabled.  
 In FMS mode, you cannot use the **portCfgPersistence** command.

The following example disables port 3 and persistently disables port 4, both in slot 2.

```
switch:admin> portdisable 2/3
switch:admin> portcfgpersistentdisable 2/4
```

The following example changes port 4 to be normal disabled instead of persistently disabled.

```
switch:admin> portcfgpersistence --set -persistentenable 2/4
```

## Port decommissioning

Port decommissioning provides an automated mechanism to remove an E\_Port or E\_Port trunk port from use.

The port decommissioning feature identifies the target port and communicates the intention to decommission the port to those systems within the fabric affected by the action. Each affected system can agree or disagree with the action, and these responses are automatically collected before a port is decommissioned.

Fabric OS 7.1.0 and later provides F\_Port decommissioning and recommissioning using Brocade Network Advisor 12.1.0 and later. Refer to the *Brocade Network Advisor User Manual* for details.

### NOTE

All members of a trunk group must have an equal link cost value in order for any of the members to be decommissioned. If any member of a trunk group does not have an equal cost, requests to decommission a trunk member will fail and an error reminding the caller of this requirement is produced.

The following restrictions apply to port decommissioning:

- The local switch and the remote switch on the other end of the E\_Port must both be running Fabric OS 7.0.0 or later.
- Port decommissioning is not supported on ports with DWDM, CWDM, or TDM.
- Port decommissioning requires that the lossless feature is enabled on both the local switch and the remote switch.

Use the **portDecom** command to begin the decommission process.

## Setting port speeds

Use the following procedure to set port speeds.

1. Connect to the switch and log in using an account with admin permissions.
2. Enter the **portCfgSpeed** command.

The following example sets the speed for port 3 on slot 2 to 16 Gbps:

```
switch:admin> portcfgspeed 2/3 16
```

The following example sets the speed for port 3 on slot 2 to auto-negotiate:

```
switch:admin> portcfgspeed 2/3 0
```

## Setting all ports on a switch to the same speed

Use the following procedure to set all ports on a switch to the same speed.

1. Connect to the switch and log in using an account with admin permissions.
2. Enter the **switchCfgSpeed** command.

If the specified speed is not supported on a particular port or blade, then that port or blade is skipped and the speed is not changed.

The following example sets the speed for all ports on the switch to 8 Gbps:

```
switch:admin> switchcfgspeed 8
Committing configuration...done.
```

The following example sets the speed for all ports on the switch to autonegotiate:

```
switch:admin> switchcfgspeed 0
Committing configuration...done.
```

## Setting port speed for a port octet

You can use the **portCfgOctetSpeedCombo** command to set the octet mode for all ports in an octet.

Fabric OS supports the following per-octet speed combinations. All ports in the same octet can support only the port speeds mentioned in the applicable column of the table below for that combination.

Port Octet in Combination	Gen 6 octet modes	Gen 5 octet modes
1 (default)	32G   16G   8G   4G	16G   8G   4G   2G
2	10G   8G   4G	8G   4G
3	Not supported	16G   10 G

A port octet can be set to a single octet mode. The ports in the octet can run on speeds supported by its octet combination. This applies to both auto-speed-negotiation and fixed speeds.

To change the octet speed combination you have to ensure the following:

1. All the fixed-speed ports must be configured at a speed which is supported in the above combination.
2. All the online ports in auto-negotiation mode must have a negotiated speed which is supported in the the above combination. If the port is running at a speed not supported in the specified combination, user needs to disable the port or change the speed to a supported fixed speed in order to change the combo.
3. All the ports which are in media invalid state should be disabled before the octet combo is changed.

If the conditions are not met, the combination change operations will fail with an appropriate error message. On getting the error message you can configure the ports to a supported speed in the specific combo or can disable the online port(s).

Example 1: If you have ports 0-7 octet set to combination 1, port 0 may be set to ASN up to 32G, port 1 to ASN up to 16G, port 2 to fixed 8G, port 3 to fixed 4G, etc as long as only port speeds of 4G, 8G, 16G, or 32G are configured.



Example 2: if you have ports 8-15 octet set to combination 2, port 8 may be set to fixed 10G, port 9 to ASN up to 8G, port 10 to ASN up to 4G, etc as long as only port speeds of 4G, 8G, or 10G are configured.

The octet can be specified by any port within the octet. To change the first octet, for example, any port from 0, 1, through 7 can be used as port argument value.

This command is non-disruptive. If any of the ports do not meet the conditions mentioned above, the operation fails and you have to change the port speed or disable the ports and retry the operation.

#### NOTE

Be aware that in a Virtual Fabrics environment, this command configures the speed of a port octet chassis-wide and not only on the logical switch.

This feature is supported on Gen 6 (32-Gbps) and Gen 5 (16-Gbps) switches and ports, except for the core blades, the FC16-64 port blade, and the Brocade 7840 Extension switch.

1. Connect to the switch and log in using an account with admin permissions.
2. Enter the **portCfgOctetSpeedCombo** command.

The following example configures the ports in the first octet for combination 3 (support autonegotiated or fixed port speeds of 16 Gbps and 10 Gbps):

```
switch:admin> portcfgoctetspeedcombo 1 3
```

If the combo cannot be switched without disrupting the ports, the following message is displayed indicating which ports must be disabled and which speed configurations must be changed. Octet combo information is stored in the configuration file. All the configuration operations will be supported with octet speed combo.

```
portcfgoctetspeedcombo 5 2
The following ports must be disabled or speed configuration needs to be change.
Please retry the operation after taking appropriate aciton.
```

```
Speeds supported for octet combo 2 - [10G,8G,4G,AN]
```

Port	Speed
0	AN
1	N16+
2	N16+
3	N16+
4	AN
5	N8
6	N8
7	N16+

```
* Port speed configuration must be changed
+ Port must be disabled
```

```
Setting octet speed combo failed
```

3. Run the **portCfgSpeed** command.

The **portCfgSpeed** command checks if the desired speed is allowed based on the combination configured for that octet. If the speed is invalid, a warning message is displayed with the suggested combination to achieve your desired speed and the command is aborted. You will then have to execute **portCfgOctetSpeedCombo** to the suggested combination before re-executing the **portCfgSpeed** command with that desired speed setting. For example, port 3's octet is in combination 1, and you specified "10", the command is rejected with the suggested combination of 2. You will then have to change the octet speed combination to 2 before retrying "10".

The supported speed for each combination is shown in the table below for Gen 6 devices.

Octet Combination	Supported <speed> Argument Setting	portCfgShow Combo String	portCfgShow Speed String
1 (32G 16G 8G 4G)	0	1	AN
	4		4G
	8		8G
	16		16G
	32		32G
2 (10G 8G 4G)	0	2	AN
	4		4G
	8		8G
	10		10

The final speed achieved also depends on the SFP used.

Example 1: If ports 0-7 octet is set to combination 1, port 0 is set to "0" and 8G SFP inserted, it can negotiate only up to 8G; if 10G SFP is inserted, port will not go online as combination 1 does not support 10G.

Example 2: if ports 8-15 octet is set to combination 2, port 8 is set to "10" but 16G SFP inserted, the port will not go online as the configured speed (10G) for that port is not supported by the SFP (16G|8G|4G).

## Setting maximum auto-negotiated port speed

If you do not know exactly at what speed a new device will connect, but you want to ensure that nothing connects faster than a certain speed, then you can configure the maximum auto-negotiated speed.

For example, if a port is configured with a maximum auto-negotiated speed of 16 Gbps, and the SFP is 32 Gbps, then the attempted speed negotiations are 16 and 8 Gbps.

### NOTE

A 32-Gbps optical transceiver in a Gen 6 device can only auto-negotiate to 32 Gbps, 16 Gbps, or 8 Gbps and a 16-Gbps optical transceiver in a Gen 6 device can only auto-negotiate to 16 Gbps, 8 Gbps, or 4 Gbps; this capability is determined by the speed of the optical transceiver at the other end of the link.

1. Connect to the switch and log in using an account with admin permissions.
2. Enter the **portCfgSpeed** command with the **-m** option.

The following example sets the maximum auto-negotiated speed to 16 Gbps for port 3 on slot 2.

```
switch:admin> portcfgspeed 2/3 0 -m 16
```

## Decoding fdmiShow command output

Prior to Fabric OS 7.4.0a, the **fdmiShow** command displays the hexadecimal data for all non-ASCII and non-WWN port attributes. This required you to lookup the hexadecimal conversion data in the standardized specifications to decode the information. Starting with Fabric OS 7.4.0a, the **fdmiShow** command automatically decodes certain hexadecimal port attribute data to ASCII format. However, if you still need to view the data in hexadecimal format, you can use the **fdmiShow -hexoutput** command.

The following example highlights the difference in the **fdmiShow** command output:

```
sw0:admin> fdmishow
Local HBA database contains:
 30:03:00:05:1e:0e:ee:b9
Ports: 1
```

```
30:03:00:05:1e:0e:ee:b9
Port attributes:
  FC4 Types: FCP
  Supported Speed: 1 2 4 8 Gb/s
  Port Speed: 8 Gb/s
  Max Frame Size: 2048 bytes
  Device Name: /proc/scsi/brcd/edsim
  Host Name: EDSIM-FDMI
  Node Name: 10:00:00:05:1e:0e:ee:b9
  Port Name: 30:03:00:05:1e:0e:ee:b9
  Port Type: N_PORT (0x1)
  Port Symb Name: dsim:fdmi_host
  Class of Service: F, 1
  Fabric Name: 00:00:00:00:00:00:00:00
  FC4 Active Type: FCP
  Port State: 0x0
  Discovered Ports: 0x1
  Port Identifier: 0x000000
```

```
HBA attributes:
  Node Name: 10:00:00:05:1e:0e:ee:b9
  Manufacturer: Brocade Communication Systems
  Serial Number: EDSIM003000
  Model: BRCD-EDSIM
  Model Description: PCI-Express Dual Channel 8Gb Fibre Channel HBA
  Hardware Version:
  Driver Version: 8.02.21
  Option ROM Version: 2.08
  Firmware Version: 4.03.01 [Multi-ID]
  OS Name and Version: Linux 2.6.14.2 #1 Wed Mar 4 14:56:56 PST 2015
```

```
Local Port database contains:
  30:03:00:05:1e:0e:ee:b9
```

```
Remote HBA database contains:
```

```
Remote Port database contains:
```

## Blade terminology and compatibility

Before configuring a chassis, familiarize yourself with the platform CP blade and port blade nomenclature, as well as the port blade compatibilities.

**TABLE 5** Core and CP blade terminology and platform support

Blade	Blade ID (slotshow)	Supported on:		Definition
		DCX 8510 family	X6 family	
CP8	50	Yes	No	Brocade DCX 8510 Backbone family control processor blade. This CP supports all blades used in the DCX 8510 Backbone families.
CR16-8	98	Yes DCX 8510-8 only	No	A core blade that has 16x4 QSFPs per blade. It can be connected to another CR16-8 or a CR16-4 core blade.
CR16-4	99	Yes DCX 8510-4 only	No	A core blade that has 8x4 QSFPs per blade. It can be connected to another CR16-4 or a CR16-8 core blade.
CPX6	175	No	Yes	Brocade X6 Backbone family control processor blade. This CP supports all blades used in the X6 Backbone families.
CR32-8	177	No	Yes X6-8 only	A core blade that has 16x4 QSFPs per blade. It can be connected to another CR32-8 or a CR32-4 core blade.
CR32-4	176	No	Yes X6-4 only	A core blade that has 8x4 QSFPs per blade. It can be connected to another CR32-4 or a CR32-8 core blade.

**TABLE 6** Port blade terminology, numbering, and platform support

Blade	Blade ID (slotshow)	Supported on:		Ports	Definition
		DCX 8510 family	X6 family		
FC32-48	178	No	Yes	48	A 48-port, 32-Gbps port blade supporting 8, 10, 16, and 32 Gbps port speeds.
SX6	186	No	Yes	24	Extension blade with 32-Gbps Fibre Channel, FCIP, and 10-GbE technology.
FC16-32	97	Yes	No	32	<p>A 32-port, 16-Gbps port blade supporting 2, 4, 8, 10, and 16 Gbps port speeds.</p> <p><b>NOTE</b> 10 Gbps speed for FC16-xx blades requires the 10G license.</p> <p>Ports are numbered from 0 through 15 from bottom to top on the left set of ports and 16 through 31 from bottom to top on the right set of ports.</p>
FC16-48	96	Yes	No	48	<p>A 48-port, 16-Gbps port blade supporting 2, 4, 8, 10, and 16 Gbps port speeds.</p> <p><b>NOTE</b> 10 Gbps speed for FC16-xx blades requires the 10G license.</p> <p>Ports are numbered from 0 through 23 from bottom to top on the left set of ports and 24 through 47 from bottom to top on the right set of ports.</p>
FC16-64	153	Yes	No	64	<p>A 64-port, 16-Gbps port blade supporting 4, 8, and 16 Gbps port speeds. These ports have 16 QSFPs per blade.</p> <p>FC Ports are numbered from 0 through 63 from bottom to top. QSFPs are numbered from 0 through 15 from bottom to top.</p>
FX8-24	75	Yes	No	12 FC 10 1-GbE 2 10-GbE	<p>Extension blade with 8-Gbps Fibre Channel, FCIP, and 10-GbE technology.</p> <p>Port numbering on this blade is as follows.</p> <p>On the left side of the blade going from bottom to top:</p> <ul style="list-style-type: none"> <li>• Six FC ports numbered from 0 through 5</li> <li>• Two 10-GbE ports numbered xge0 and xge1</li> <li>• Four 1-GbE ports numbered from ge0 through ge3</li> </ul> <p>On the right side of the blade going from bottom to top:</p> <ul style="list-style-type: none"> <li>• Six FC ports numbered from 6 through 11</li> <li>• Six 1-GbE ports numbered from ge4 through ge9</li> </ul>

## CP blades

The control processor (CP) blade provides redundancy and acts as the main controller on the Brocade Backbone. The Brocade DCX 8510 Backbone families support the CP8 blades, and X6 Backbone families support the CPX6 blades.

The CP blades in the Brocade DCX 8510 and X6 Backbone families are hot-swappable. The CP8 blades are fully interchangeable among Brocade DCX 8510-4, and DCX 8510-8 Backbones. The CPX6 blades are fully interchangeable among Brocade X6-4, and X6-8 Backbones.

Brocade recommends that each CP (primary and secondary partition) should maintain the same firmware version.

## Core blades

Core blades provide intra-chassis switching and inter-chassis link (ICL) connectivity between DCX 8510 and X6 platforms.

- Brocade DCX 8510-8 supports two CR16-8 core blades.
- Brocade DCX 8510-4 supports two CR16-4 core blades.
- Brocade X6-8 supports two CR32-8 core blades.
- Brocade X6-4 supports two CR32-4 core blades.

The core blades for each platform are not interchangeable or hot-swappable with the core blades for any other platform. If you try to interchange the blades, they may be physically incompatible or become faulty.

## Port and application blade compatibility

The maximum number of intelligent blades supported is eight on an 8-slot chassis and four on a 4-slot chassis. However, the maximum number of a specific blade type is limited.

The following table lists the maximum supported limits of each blade for a specific platform. Software functions are not supported across application blades.

### NOTE

The hardware limit is enforced by software.

**TABLE 7** Intelligent blade support within Brocade Backbone families

Intelligent blade	DCX 8510-8	DCX 8510-4	X6-8	X6-4
FX8-24	4	4	Not supported	Not supported
SX6	Not supported	Not supported	4	4

Follow these guidelines when using an FX8-24, 7800, 7840 and SX6 platforms

- Brocade FX8-24 blade and 7800 cannot be connected to the 7840 and SX6 platforms. The ports may come online, but they will not communicate with each other.
- If an FX8-24 blade is replaced by another FX8-24 blade, the previous IP configuration data would be applied to the new FX8-24.

## Enabling and disabling blades

Port blades are enabled by default. In some cases, you will need to disable a port blade to perform diagnostics. When diagnostics are executed manually (from the Fabric OS command line), many commands require the port blade to be disabled. This ensures that diagnostic activity does not interfere with normal fabric traffic.

If you need to replace an application blade with a different application blade, there may be extra steps you need to take to ensure that the previous configuration is not interfering with your new application blade.

## Enabling blades

Use the following procedure to enable a blade.

1. Connect to the switch and log in using an account with admin permissions.

2. Enter the **bladeEnable** command with the slot number of the port blade you want to enable.

```
ecp:admin> bladeenable 3
Slot 3 is being enabled
```

## Exceptions in enabling 48-port and 64-port blades

Because the area IDs are shared with different port IDs, the 48-port and 64-port blades support only F\_Ports and E\_Ports. They do not support FL\_Ports. (FL\_Ports are not supported on any of the 16-Gbps or 32-Gbps blades.)

Port swapping is not supported on 48-port and 64-port blades. For the 32-port blades, port swapping is supported on all 32 ports. This means that if you replace a 32-port blade where a port has been swapped with a 48-port blade, the 48-port blade faults. To correct this, reinsert the 32-port blade and issue **portSwap** to restore the original area IDs.

## Disabling blades

Use the following procedure to disable a blade.

1. Connect to the switch and log in using an account with admin permissions.
2. Enter the **bladeDisable** command with the slot number of the port blade you want to disable.

```
ecp:admin> bladedisable 3
Slot 3 is being disabled
```

## Blade swapping

Blade swapping allows you to swap one blade with another of the same type; in this way, you can replace a FRU with minimal traffic disruption.

The entire operation is accomplished when the **bladeSwap** command runs on the Fabric OS. Fabric OS then validates each command before implementing the command on the Backbone. If an error is encountered, the blade swap quits without disrupting traffic flowing through the blades. If an unforeseen error does occur during the **bladeSwap** command, an entry will be made in the RASlog and all ports that have been swapped as part of the blade swap operation will be swapped back. On successful completion of the command, the source and destination blades are left in a disabled state, allowing you to complete the cable move.

Blade swapping is based on port swapping and has the same restrictions:

- Shared area ports cannot be swapped.
- Ports that are part of a trunk group cannot be swapped.
- GbE ports cannot be swapped.
- Faulty blades cannot be swapped.
- Swapping ports between different logical switches is not supported. The ports on the source and destination blades must be in the same logical switch.
- Undetermined board types cannot be swapped. For example, a blade swap will fail if the blade type cannot be identified.
- Blade swapping is not supported when swapping to a different model of blade or a different port count. For example, you cannot swap an FC16-32 blade with an FC16-48 port blade.

## How blades are swapped

The `bladeSwap` command performs the following operations:

1. Blade selection

The selection process includes selecting the switch and the blades to be affected by the swap operation. The following figure shows the source and destination blades identified to begin the process.

FIGURE 2 Identifying the blades

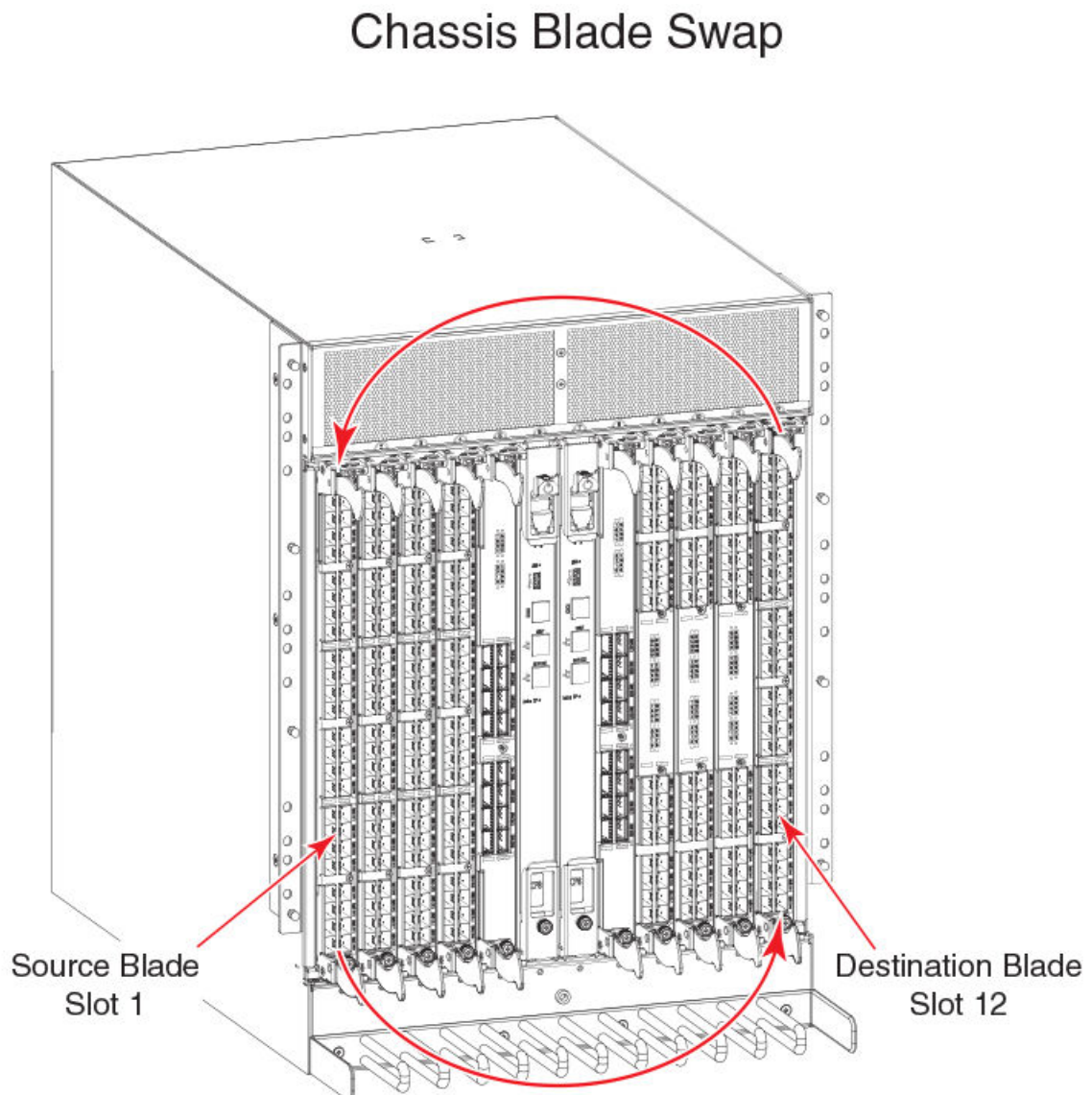

2. Blade validation

The validation process includes determining the compatibility between the blades selected for the swap operation:

- Blade technology. Both blades must be of compatible technology types (for example, Fibre Channel to Fibre Channel, Ethernet to Ethernet, application to application, and extension to extension).

- Port count. Both blades must support the same number of front ports (for example, 32 ports to 32 ports, 48 ports to 48 ports, and 64 ports to 64 ports).
- Availability. The ports on the destination blade must be available for the swap operation and not attached to any other devices.

**ATTENTION**

If you have swapped different types of blades by error, or if there is a need to swap two cards of different types, you can do that only by destructively erasing the existing blade configuration and reconfiguring the new blades and ports.

**3. Port preparation**

The process of preparing ports for a swap operation includes basic operations such as ensuring the source and destination ports are offline, or verifying that none of the destination ports have failed.

The preparation process also includes any special handling of ports associated with logical switches. For example, the following figure shows the source blade has ports in a logical switch or logical fabric, and the corresponding destination ports must be included in the associated logical switch or logical fabric of the source ports.



FIGURE 3 Blade swap with Virtual Fabrics during the swap

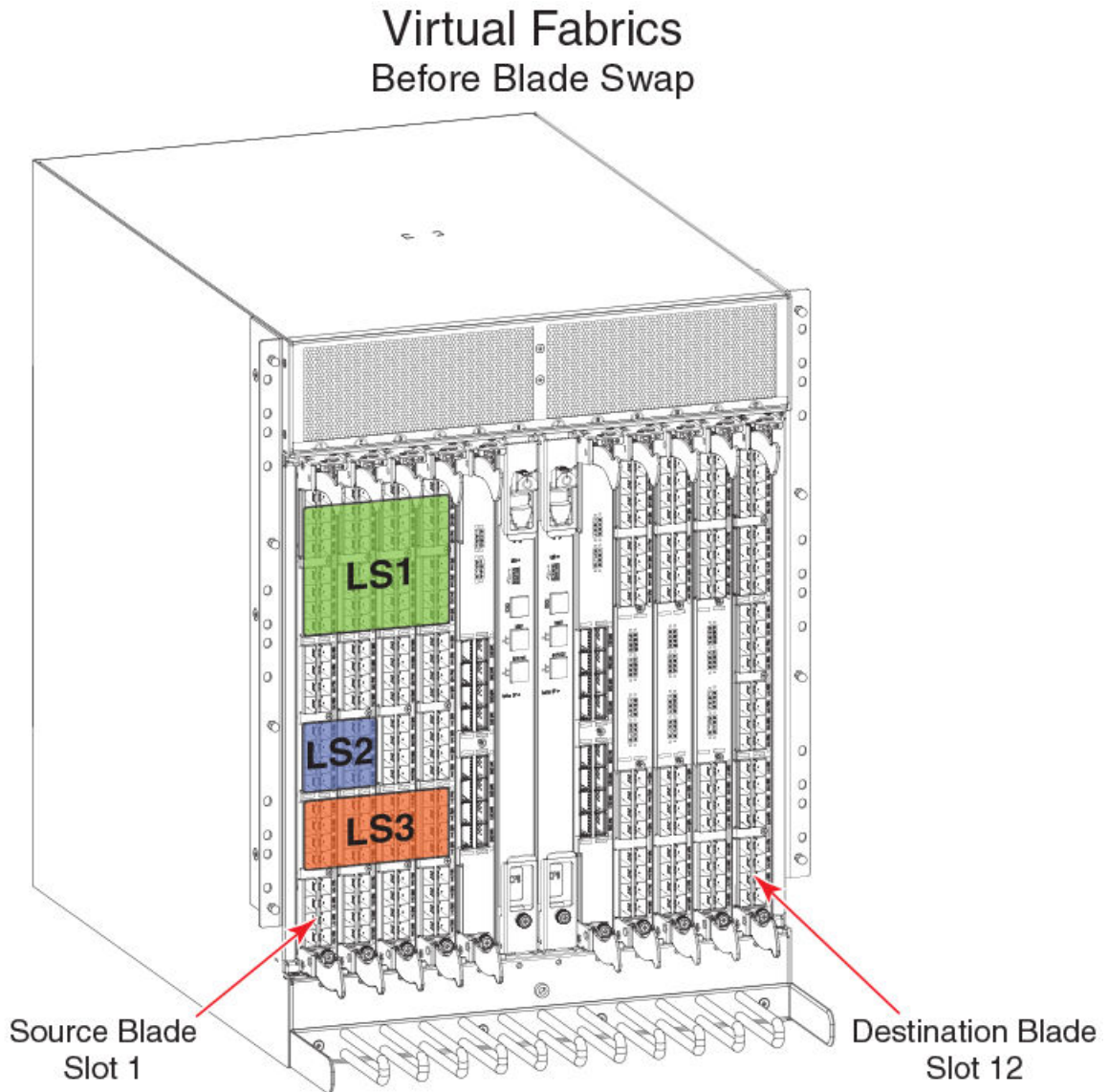

4. Port swapping

The swap ports action is an iteration of the **portSwap** command for each port on the source blade to each corresponding port on the destination blade.

As shown in the following figure, the blades can be divided into different logical switches as long as they are divided the same way. If slot 1 and slot 2 ports 0 through 7 are all in the same logical switch, then blade swapping slot 1 to slot 2 will work. The entire blade does not need to be in the same partition.

FIGURE 4 Blade swap with Virtual Fabrics after the swap

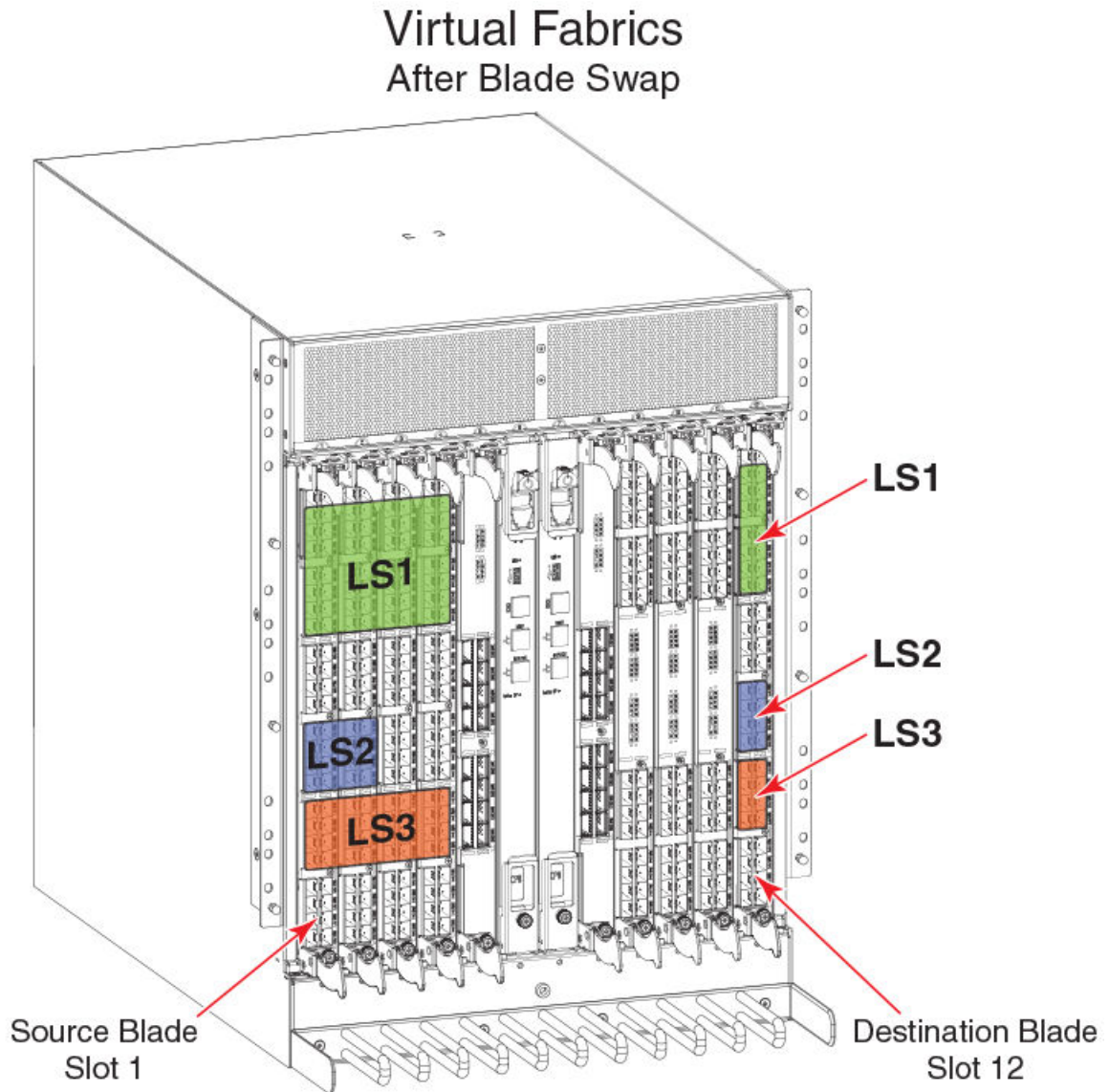

## Swapping blades

Use the following procedure to swap blades.

1. Connect to the Backbone and log in using an account with admin permissions.
2. Enter the **bladeSwap** command.

If no errors are encountered, the blade swap will complete successfully. If errors are encountered, the command is interrupted and the ports are set back to their original configurations.

3. Once the command completes successfully, move the cables from the source blade to the destination blade.
4. Enter the **bladeEnable** command on the destination blade to enable all user ports.

## Disabling switches

Switches are enabled by default. In some cases, you may need to disable a switch to perform diagnostic testing. This ensures that diagnostic activity does not interfere with normal fabric traffic.

Use the following procedure to disable a switch.

1. Connect to the switch and log in using an account with admin permissions.
2. Enter **switchCfgPersistentDisable --setdisablestate**.

This procedure sets the switch to the disabled state without disabling it. On reset, the switch will be in a disabled state, and will need to be enabled.

## Power management

To manage power and ensure that more critical components are the least affected by power changes, you can specify the order in which the components are powered off by using the **powerOffListSet** command.

The power monitor compares the available power with the power required to determine if there will be enough power to operate. If it is predicted to be less power available than required, the power-off list is processed until there is enough power for operation. By default, the processing begins with slot 1 and proceeds to the last slot in the chassis. As power becomes available, slots are powered up in the reverse order. During the initial power up of a chassis, or using the **slotPowerOn** command, or the insertion of a blade, the available power is compared to required power before power is applied to the blade.

### NOTE

Some FRUs in the chassis may use significant power, yet cannot be powered off through software.

The **powerOffListShow** command displays the power-off order.

## Powering off a port blade or core blade

Blades cannot be powered off when POST or AP initialization is in progress.

The CP blades cannot be powered off from the CLI. You must manually power off the CP blades by lowering the slider or removing power from the chassis. If the CP is not up and running, then physical removal or powering off the chassis is required.

### ATTENTION

Powering off the last operational core blade disables the chassis.

1. Connect to the switch and log in using an account with admin permissions.
2. Enter the **slotPowerOff** command with the slot number of the port blade or core blade you want to power off.

```
ecp:admin> slotpoweroff 3

Slot 3 is being powered off

ecp:admin> slotpoweroff 5

You have chosen a core blade to power off,
if this is the last operational core blade, then
the chassis will disable itself.
Would you like to proceed? (yes, y, no, n):[no] y
```

## Powering on a port blade or core blade

All blades are powered on by default when the switch chassis is powered on.

1. Connect to the switch and log in using an account with admin permissions.
2. Enter the **slotPowerOn** command with the slot number of the port blade or core blade you want to power on.

```
ecp:admin> slotpoweron 3
Powering on slot 3
```

## Equipment status

You can check the status of switch operation, High Availability features, and fabric connectivity.

### Checking switch operation

Use the following procedure to check switch operation.

1. Connect to the switch and log in using an account with admin permissions.
2. Enter the **switchShow** command. This command displays a switch summary and a port summary.
3. Check that the switch and ports are online.

## Verifying High Availability features (Backbones and Directors only)

High Availability (HA) features provide maximum reliability and nondisruptive management of key hardware and software modules.

Use the following procedure to verify High Availability features for a Brocade DCX 8510 Backbones and X6 Directors.

1. Connect to the switch and log in using an account with admin permissions.
2. Enter the **chassisShow** command to verify the model of the DCX or X6 and obtain a listing of all field-replaceable units (FRUs).
3. Enter the **haShow** command to verify HA is enabled, the heartbeat is up, and that the HA state is synchronized between the active and standby CP blades.
4. Enter the **haRedundancy --show** command to display the CP redundancy settings and switch uptime.

```
X6-8:FID165:admin> haredundancy --show
=== HA Redundancy Statistics ===
  HA State synchronized
  Current Active Session:
  Active Slot = CP0 (Local), Expected Recovered
  Standby Slot = CP1 (Remote)
  Start Time: 17:55:33 UTC Fri Jan 03 2014

  Previous Active Session:
  Active Slot = CP1, Expected Recovered
  Standby Slot = CP0
  Start Time: 17:49:46 UTC Fri Jan 03 2014
  End Time: 17:54:10 UTC Fri Jan 03 2014

  System Uptime: 17:42:11 UTC Fri Jan 03 2014
```

5. Enter the **fanShow** command to display the current status and speed of each fan in the system. Refer to the hardware reference manual of your system to determine the appropriate values.
6. Enter the **psShow** command to display the current status of the switch power supplies. Refer to the hardware reference manual of your system to determine the appropriate values.

- Enter the **slotShow -m** command to display the inventory and the current status of each slot in the system.

### Example of the slot information displayed for a X6-8 Director chassis

```
X6-8:FID165:admin> slotshow -m
```

Slot	Blade Type	ID	Model Name	Status
1	CP BLADE	175	CPX6	ENABLED
2	CP BLADE	175	CPX6	ENABLED
3	SW BLADE	178	FC32-48	ENABLED
4	SW BLADE	178	FC32-48	ENABLED
5	SW BLADE	178	FC32-48	ENABLED
6	SW BLADE	178	FC32-48	ENABLED
7	CORE BLADE	177	CR32-8	ENABLED
8	CORE BLADE	177	CR32-8	ENABLED
9	SW BLADE	178	FC32-48	ENABLED
10	EXT BLADE	186	SX6	ENABLED
11	SW BLADE	178	FC32-48	ENABLED
12	EXT BLADE	186	SX6	ENABLED

### Verifying fabric connectivity

Use the following procedure to verify fabric connectivity.

- Connect to the switch and log in using an account with admin permissions.
- Enter the **fabricShow** command. This command displays a summary of all the switches in the fabric.

The output of the **fabricShow** command is discussed in [Domain IDs](#) on page 61.

### Verifying device connectivity

Use the following procedure to verify device connectivity.

- Connect to the switch and log in using an account with admin permissions.
- Optional: Enter the **switchShow** command to verify devices, hosts, and storage are connected.
- Optional: Enter the **nsShow** command to verify devices, hosts, and storage have successfully registered with the name server.
- Enter the **nsAllShow** command to display the 24-bit Fibre Channel addresses of all devices in the fabric.

```
switch:admin> nsallshow
```

```
{
  010e00 012fe8 012fef 030500 030b04 030b08 030b17 030b18
  030b1e 030b1f 040000 050000 050200 050700 050800 050de8
  050def 051700 061c00 071a00 073c00 090d00 0a0200 0a07ca
  0a07cb 0a07cc 0a07cd 0a07ce 0a07d1 0a07d2 0a07d3 0a07d4
  0a07d5 0a07d6 0a07d9 0a07da 0a07dc 0a07e0 0a07e1 0a0f01
  0a0f02 0a0f0f 0a0f10 0a0f1b 0a0f1d 0b2700 0b2e00 0b2fe8
  0b2fef 0f0000 0f0226 0f0233 0f02e4 0f02e8 0f02ef 210e00
  211700 211fe8 211fef 2c0000 2c0300 611000 6114e8 6114ef
  611600 620800 621026 621036 6210e4 6210e8 6210ef 621400
  621500 621700 621a00
  75 Nx_Ports in the Fabric }
```

The number of devices listed should reflect the number of devices that are connected.

### Audit log configuration

When managing SANs, you may want to audit certain classes of events to ensure that you can view and generate an audit log for what is happening on a switch, particularly for security-related event changes. These events include login failures, zone configuration changes,

firmware downloads, and other configuration changes; in other words, critical changes that have a serious effect on the operation and security of the switch.

Important information related to event classes is also tracked and made available. For example, you can track changes from an external source by the user name, IP address, or type of management interface used to access the switch.

Auditable events are generated by the switch and streamed to an external host through a configured system message log daemon (syslog). You specify a filter on the output to select the event classes that are sent through the system message log. The filtered events are streamed chronologically and sent to the system message log on an external host in the specified audit message format. This ensures that they can be easily distinguished from other system message log events that occur in the network. Then, at some regular interval of your choosing, you can review the audit events to look for unexpected changes.

Before you configure audit event logging, familiarize yourself with the following audit event log behaviors and limitations:

- By default, *all event classes* are configured for audit; to create an audit event log for specific events, you must explicitly set a filter with the **class** operand and then enable it.
- Audited events are generated specific to a switch and have no negative impact on performance.
- The last 1024 messages are persistently saved in the audit log, but all audit events are sent to the system message log, which — assuming there are no bottlenecks — will be forwarded to your syslog server.
- The audit log depends on the system message log facility and IP network to send messages from the switch to a remote host. Because the audit event log configuration has no control over these facilities, audit events can be lost if the system message log and IP network facilities fail.
- If too many events are generated by the switch, the system message log becomes a bottleneck and audit events are dropped by the Fabric OS.
- If the user name, IP address, or user interface is not transported, “None” is used instead for each of the respective fields.
- For High Availability, the audit event logs exist independently on both active and standby CPs. The configuration changes that occur on the active CP are propagated to the standby CP and take effect.
- Audit log configuration is also updated through a configuration download.

Before configuring an audit log, you must select the event classes you want audited.

#### NOTE

Only the active CP can generate audit messages because event classes being audited occur only on the active CP. Audit messages cannot originate from other blades in a Backbone.

Switch names are logged for switch components and Backbone names for Backbone components. For example, a Backbone name may be FWDL or RAS and a switch component name may be zone, name server, or SNMP.

Refer to the *Fabric OS Message Reference* for details on event classes and message formats. For more information on setting up the system error log daemon, refer to the *Fabric OS Troubleshooting and Diagnostics Guide*.

#### NOTE

If an AUDIT message is logged from the CLI, any environment variables will be initialized with proper values for login, interface, IP and other session information. Refer to the *Fabric OS Message Reference* for more information.

## Verifying host syslog prior to configuring the audit log

Audit logging assumes that your syslog is operational and running. Before configuring an audit log, you must perform the following steps to ensure that the host syslog is operational.

1. Set up an external host machine with a system message log daemon running to receive the audit events that will be generated.

2. On the switch where the audit configuration is enabled, enter the **syslogAdmin** command to add the IP address of the host machine so that it can receive the audit events.

You can use IPv4, IPv6, or DNS names for the **syslogAdmin** command.

3. Ensure the network is configured with a network connection between the switch and the remote host.
4. Check the host syslog configuration. If all error levels are not configured, you may not see some of the audit messages.

## Configuring an audit log for specific event classes

1. Connect to the switch from which you want to generate an audit log and log in using an account with admin permissions.
2. Enter the **auditCfg --class** command, which defines the specific event classes to be filtered.

### NOTE

By default, audit log is enabled for all event classes.

```
switch:admin> auditcfg --class 2,4
Audit filter is configured.
```

3. Enter the **auditCfg --enable** command, which enables audit event logging based on the classes configured in step 2.

```
switch:admin> auditcfg --enable
Audit filter is enabled.
```

To disable an audit event configuration, enter the **auditCfg --disable** command.

4. Enter the **auditCfg --show** command to view the filter configuration and confirm that the correct event classes are being audited, and the correct filter state appears (enabled or disabled).

```
switch:admin> auditcfg --show
Audit filter is enabled.
2-SECURITY
4-FIRMWARE
```

5. Enter the **auditDump -s** command to confirm that the audit messages are being generated.

## Example of the syslog (system message log) output for audit logging

```
Oct 10 08:52:06 10.3.220.7 raslogd: AUDIT, 2008/10/10-08:20:19 (GMT), [SEC-3020], INFO, SECURITY, admin/admin/10.3.220.13/telnet/CLI, ad_0/ras007/FID 128, , Event: login, Status: success, Info: Successful login attempt via REMOTE, IP Addr: 10.3.220.13.
Oct 10 08:52:23 10.3.220.7 raslogd: 2008/10/10-08:20:36, [CONF-1001], 13, WWN 10:00:00:05:1e:34:02:0c | FID 128, INFO, ras007, configUpload completed successfully. All config parameters are uploaded.
Oct 10 09:00:04 10.3.220.7 raslogd: AUDIT, 2008/10/10-08:28:16 (GMT), [SEC-3021], INFO, SECURITY, admin/NONE/10.3.220.13/None/CLI, None/ras007/FID 128, , Event: login, Status: failed, Info: Failed login attempt via REMOTE, IP Addr: 10.3.220.13.
```

## Configuring remote syslog servers

Fabric OS supports configuring a switch to forward all error log entries to a remote syslog server, to set the syslog facility to a specified log file, to remove a syslog server, and to display the list of configured syslog servers. Brocade switches use the syslog daemon, a process available on most UNIX systems that reads and forwards system messages to the appropriate log files or users, depending on the system configuration. Up to six servers are supported.

By default, the switch uses UDP protocol to send the error log messages to the syslog server. The default UDP port is 514. Use the **-secure** option to configure the switch to send the error log messages securely using the Transport Layer Security (TLS) protocol. TLS is



an encryption protocol over the TCP/IP network protocol and it can be used only with the TCP-based destinations (tcp() and tcp6()). The default TLS port is 6514. While enabling secure syslog mode, you must specify a port that is configured to receive the log messages from the switch.

Refer to the following examples to configure syslog server hosts.

To configure an IPv4 secure syslog server to which error log messages are sent:

```
switch:admin> syslogadmin --set -ip 172.26.26.173 -secure -port 2000
```

To configure an IPv6 non-secure syslog server:

```
switch:admin> syslogadmin --set -ip fec0:60:69bc:92:218:8bff:fe40:15c4
```

To set the syslog facility to LOG\_LOCAL2:

```
switch:admin> syslogadmin --set -facility 2
switch:admin> syslogadmin --show -facility
Syslog facility: LOG_LOCAL2
```

To display all syslog IP addresses configured on a switch:

```
switch:admin> syslogadmin --show -ip
syslog.1 172.26.26.173
syslog.2 fec0:60:69bc:92:218:8bff:fe40:15c4
```

To remove the IP address fec0:60:69bc:92:218:8bff:fe40:15c4 from the list of servers to which error log messages are sent:

```
switch:admin> syslogadmin --remove -ip fec0:60:69bc:92:218:8bff:fe40:15c4
```

## Using secure syslog CA certificates

Starting with Fabric OS 7.4.0, you can import and export syslog CA certificates.

- Use the following command to import syslog CA certificates.

```
seccertutil import -syslogcacert
```

- Use the following command to delete syslog CA certificates.

```
seccertutil delete -syslogcacert [<certificate name>]
```

- Use the following command to export syslog CA certificates.

```
seccertutil export -syslogcacert [-certname <certificate name>]
```

- Use the following command to display the syslog CA certificates.

```
seccertutil show -syslogcacert
```

## Hostname support for syslogAdmin command

The **syslogAdmin** command accepts either IP address or hostname as input for the syslog server. The system does not validate the host name. You must ensure that you enter the correct host name.

- Sample commands for hostname and IP address as input:

```
switch:admin> syslogadmin --set -ip win2k8-58-113
Syslog host name win2k8-58-113 added
switch:admin>
switch:admin> syslogadmin --set -ip 10.20.58.113
Syslog IP address 10.20.58.113 added
```



- Sample output of the syslog server information:

```
switch:admin> syslogadmin --show -ip
syslog.1          10.20.58.113
syslog.2          win2k8-58-113
```

- Sample command to remove the syslog server hostname:

```
switch:admin> syslogadmin --remove -ip win2k8-58-113
Syslog hostname win2k8-58-113 removed
```

## Duplicate PWWN handling during device login

If a device attempts to log in with the same port WWN (PWWN) as another device on the same switch, you can configure whether the new login or the existing login takes precedence.

Note that if a device attempts to log in with the same PWWN as another device on a different switch, both devices are logged out. This section describes what happens with devices logging in on the same switch.

You can configure how duplicate PWWNs are handled by selecting an option in the Enforce FLOGI/FDISC login prompt of the **configure** command:

- Setting 0: First login takes precedence over second login (default behavior).
- Setting 1: Second login overrides first login.
- Setting 2: The port type determines whether the first or second login takes precedence.

### Setting 0, First login precedence

When setting 0 is selected, the first login takes precedence over the second. This is the default behavior. The following table describes the behavior when setting 0 is selected.

**TABLE 8** Duplicate PWWN behavior: First login takes precedence over second login

Input port	First port login is NPIV port	First port login is F_Port
FLOGI received	The new login is rejected and the new port is persistently disabled.	The new login is rejected and the new port is persistently disabled.
FDISC received	The new FDISC is rejected.	The new FDISC is rejected.

### Setting 1, Second login precedence

When setting 1 is selected, the second login takes precedence over the first. The following table describes the behavior when setting 1 is selected.

**TABLE 9** Duplicate PWWN behavior: Second login overrides first login

Input port	First port login is F_Port	First port login is NPIV port
FLOGI received	New login forces an explicit logout of original login on the previous F_Port. The previous F_Port is persistently disabled.	New login forces an explicit logout of original FDISC on the previous NPIV port. If Base Device Logout is enabled on the NPIV port, only the base device is logged out and the remaining NPIV devices stay logged in.
FDISC received	New FDISC forces an explicit logout of original login on the previous F_Port. The previous F_Port is persistently disabled.	New FDISC forces an explicit logout of original FDISC on the previous NPIV port.

**TABLE 9** Duplicate PWWN behavior: Second login overrides first login (continued)

Input port	First port login is F_Port	First port login is NPIV port
		If Base Device Logout is enabled on the NPIV port, only the base device is logged out and the remaining NPIV devices stay logged in.

## Setting 2, Mixed precedence

When setting 2 is selected, the precedence depends on the port type of the first login:

- If the previous port is an F\_Port, the first login takes precedence.
- If the previous port is an NPIV port, the second login overrides the first login.

**TABLE 10** Duplicate PWWN behavior: Port type determines which login takes precedence

Input port	First port login is NPIV port	First port login is F_Port
FLOGI received	New login forces an explicit logout of original FDISC on the previous NPIV port.  If Base Device Logout is enabled on the NPIV port, only the base device is logged out and the remaining NPIV devices stay logged in.	New login is rejected and the new port is persistently disabled.
FDISC received	New FDISC forces an explicit logout of original FDISC on the previous NPIV port.  If Base Device Logout is enabled on the NPIV port, only the base device is logged out and the remaining NPIV devices stay logged in.	New FDISC is rejected.

## Setting the behavior for handling duplicate PWWNs

You can configure how duplicate port WWNs (PWWNs) are handled if a device attempts to log in with the same PWWN as another device on the switch.

1. Connect to the switch and log in using an account with admin permissions.
2. Enter the **switchDisable** command to disable the switch.
3. Enter the **configure** command.
4. Enter **y** after the F\_Port login parameters prompt.
 

```
F-Port login parameters (yes, y, no, n): [no] y
```
5. Enter one of the following options at the Enforce FLOGI/FDISC login prompt to select the behavior for handling duplicate PWWNs.
  - Enter **0** to have the first login take precedence over the second login (default).
  - Enter **1** to have the second login override the first login.
  - Enter **2** to have the port type determine the behavior.

If a duplicate login is received on an F\_Port, the duplicate login is rejected and the old login is preserved; if a duplicate login is received on an NPIV port, the newer login is accepted.

```
Enforce FLOGI/FDISC login: (0..2) [0] 1
```

6. Respond to the remaining prompts, or press **Ctrl + D** to accept the other settings and exit.

7. Enter the **switchEnable** command to re-enable the switch.

With any of these settings, detection of duplicate PWWNs results in a RASLog. Ports that are restricted become persistently disabled, marked with the reason "Duplicate Port WWN detected".

## Forward error correction

Forward error correction (FEC) provides a data transmission error control method by including redundant data (error-correcting code) to ensure error-free transmission on a specified port or port range. When 10/16G FEC is enabled, it can correct one burst of up to 11-bit errors in every 2112-bit transmission, whether the error is in a frame or a primitive. When 32G FEC is enabled, it can correct up to 7 symbols in every 5280-bit transmission. A symbol consists of 10 bits, so there are 528 symbols in every 5280-bit transmission.

Since FEC is optional, the Transmitter Training Signal (TTS) was extended to include a means to negotiate FEC capabilities. FEC is negotiated and activated when both sides of the link have FEC enabled. The FEC active indicator in the Fabric OS indicates whether or not FEC was successfully negotiated or not. FEC uses unused bits within the signaling protocol to generate an Error Correcting Code (ECC) and correct bits as needed.

The following considerations apply to FEC:

- FEC is always active on ports operating at 32 Gbps speed based on the standard, regardless of the FEC settings on the switch.
- FEC is supported on E\_Ports on 16 Gbps-capable switches at 10/16G speeds.
- FEC is supported on the N\_Ports and F\_Ports of an Access Gateway using RDY, Normal (R\_RDY), or Virtual Channel (VC\_RDY) flow control modes.
- FEC is supported on F\_Ports if the device attached to it supports FEC.
- FEC is enabled by default.
- FEC enables automatically when negotiation with a switch detects FEC capability.
- FEC persists after driver reloads and system reboots.
- FEC functions with features such as QoS, trunking, and BB\_Credit recovery.

## FEC limitations

The following limitations apply to Forward Error Correction (FEC):

- FEC is configurable only on 16 and 32 Gbps-capable switches (Brocade 6505, 6510, 6520, G620, M6505, 6547, 6548, 7840, and the Brocade DCX 8510 and X6 Director family). 32 Gbps is supported only with Fabric OS 8.0.0 and later. FEC is mandatory for ports operating at 32 Gbps speed and hence enabled by default.
- For switch-to-adaptor connections, FEC is supported only on QLogic BR-1860 and BR-1867 with driver v3.2.x on the Fabric Adapter ports operating in HBA mode connected to 16- and 32- Gbps Brocade switches running Fabric OS 7.1 and later.
- FEC is supported only on link speeds of 10-Gbps, 16-Gbps, and 32-Gbps regardless of whether the platform is FEC-capable.
- To connect between a switch and an HBA at 16 or 32 Gbps, both sides must be in the same mode (fixed speed, and FEC on or off) for them to communicate at that rate. If only one port has FEC enabled, neither port will be able to see the other. If the ports are in dynamic mode, then they may connect, but not at 16 or 32 Gbps.
- FEC is not active unless enabled when the HBA port speed changes to less than 16 or 32 Gbps.
- DWDM in transparent mode supports FEC.

## Enabling forward error correction

Use the following procedure to enable FEC.

**ATTENTION**

Enabling FEC is disruptive to traffic. FEC can be enabled or disabled only at 16 Gbps, or at 10 Gbps on E\_Ports with octet mode 2 or 3 on Gen 5 devices. The FEC is always enabled at 32 Gbps.

1. Connect to the switch and log in using an account with admin permissions.
2. Enter the **portCfgFec --enable** command, specifying the port or range of ports on which FEC is to be enabled.

```
portcfgfec --enable -FEC slot/port
```

3. Enter the **portCfgFec --show** command to display the current FEC configuration.

```
portcfgfec --show slot/port
```

### Enabling FEC on a single port

```
switch:admin> portcfgfec --enable -FEC 1
Warning : FEC changes will be disruptive to the traffic
FEC has been enabled.
```

```
switch:admin> portcfgfec --show 1
```

```
Port: 1
FEC Capable: YES
10G/16G FEC Configured: ON
16 FEC via TTS Configured: OFF
FEC State: active
```

### Disabling forward error correction

Use the following procedure to disable FEC.

**ATTENTION**

Disabling FEC is disruptive to traffic and can be disabled at 10, 16, 32 Gbps. However, FEC is always active (even if disabled) at 32 Gbps.

1. Connect to the switch and log in using an account with admin permissions.
2. Enter the **portCfgFec --disable** command, specifying the port or range of ports on which FEC is to be disabled.

```
portcfgfec --disable -FEC slot/port
```

3. Enter the **portCfgFec --show** command to display the current FEC configuration.

```
portcfgfec --show slot/port
```

### Disabling FEC on a single port

```
switch:admin> portcfgfec --disable -FEC 1
Warning : FEC changes will be disruptive to the traffic
FEC has been disabled.
```

```
switch:admin> portcfgfec --show 1
```

```
Port: 1
FEC Capable: YES
10G/16G FEC Configured: OFF
16G FEC via TTS Configured: OFF
FEC State: Inactive
```

## Enabling or disabling FEC for long-distance ports

To enable or disable FEC for long-distance ports, use `portCfgLongDistance` with the `-fecEnable` or `-fecDisable` parameter as required.

```
switch:admin> portcfglongdistance 12/6 LS 1 -distance 100 -fecenable
```

Refer to [Managing Long-Distance Fabrics](#) on page 483 for more details on working with long-distance ports.

## Displaying and clearing the FEC counters

Both correctable and uncorrectable FEC counters help you to identify link degradation and take actions.

1. Run the `portStatsShow` and `portStats64Show` commands to display the counters.

```
Stinger3:FID128:root> portstatsshow 16 | grep fec
fec_cor_detected      1111      Count of blocks that were corrected by FEC
fec_uncor_detected    0         Count of blocks that were left uncorrected by FEC

Stinger3:FID128:root> portstats64show 16
...
stat64_fec_cor      0         top_int : FEC corrected errors detected
                  1111      bottom_int : FEC corrected errors detected
stat64_fec_uncor    0         top_int : FEC uncorrected errors detected
                  0         bottom_int : FEC uncorrected errors detected
```

### NOTE

"fec\_cor\_detected" is displayed on Gen 5 platforms. Gen 6 platforms display "fec\_uncor\_detected".

2. Run the `portStatsClear` command to clear the counters.

## FEC-via-TTS

All devices that support FEC-via-TTS have it enabled by default; however, not all devices that support 16 Gbps support FEC-via-TTS. FEC-via-TTS is negotiated during speed negotiation when a link comes up. Any HBA or device connection that supports 16 Gbps but not FEC-via-TTS auto-negotiates to 8 Gbps. Therefore, FEC-via-TTS must only be enabled on switch ports intended for connections to HBAs and devices that support FEC-via-TTS. A Brocade to Brocade ISL connection does not utilize TTS to enable FEC; consequently, FEC-via-TTS must be disabled on all E\_Ports. When FEC-via-TTS is enabled on a port, the port will automatically be disabled when connected to another Brocade 16 Gbps Gen 5 switch.

- FEC-via-TTS is disabled by default.
- When enabling FEC-via-TTS, the port is momentarily disabled and therefore is a disruptive action. FEC-via-TTS is active only when both ends of the link have FEC enabled.
- E\_Port connectivity is not supported when FEC-via-TTS is enabled on the switch port.
- DWDM devices do not support FEC-via-TTS.
- FEC-via-TTS is supported only on QLE267x and QLE274x with driver v9.1.14.22 and later. Prior to enabling FEC Transmitter Training Signal (TTS) mode, refer to your HBA documentation to confirm FEC-via-TTS functionality and support.
- FEC-via-TTS displays **ON** when control of the FEC state is permitted via TTS by an externally attached host or device even if the peer does not support it. Displays **Active** when FEC has been negotiated between the switch and the attached HBA or device. Displays **(.)** or **OFF** when the external control of FEC is disabled.

FEC-via-TTS can be enabled or disabled using the CLI on a port range on a fixed-port switch or on a port range within a slot for Directors. FEC-via-TTS is a method to negotiate FEC when FEC is supported on Gen 5 links. Therefore, FEC must be enabled as well.

1. Before executing any commands, remember to set the CLI context to the fabric ID (FID) for the logical switch. For example, to set the context to FID 1:

```
switch:admin> setcontext 1
```

2. To enable FEC-via-TTS on all ports of a 32-port blade in slot 1 without confirmation:

```
switch:admin> portcfgfec --enable -tts -f 1/0-31
```

3. To enable FEC-via-TTS on port 0 of slot 1 with confirmation:

```
switch:admin> portcfgfec --enable -tts 1/0
```

4. To disable FEC-via-TTS on port 0 of slot 1 without confirmation:

```
switch:admin> portcfgfec --disable -tts -f 1/0
```

5. To disable FEC on port 0 of slot 1 without confirmation:

```
switch:admin> portcfgfec --disable -fec -f 1/0
```

# Routing Traffic

---

• Routing overview.....	107
• Inter-switch links.....	109
• Gateway links.....	112
• Routing policies.....	114
• Route selection.....	116
• Frame order delivery.....	117
• Lossless Dynamic Load Sharing on ports.....	120
• Frame Redirection.....	123

## Routing overview

Data moves through a fabric from switch to switch and from storage to server along one or more paths that make up a *route*. Routing policies determine the path for each frame of data.

Before the fabric can begin routing traffic, it must discover the route a packet should take to reach the intended destination. Route tables are lists that indicate the next hop to which packets are directed to reach a destination. Route tables include network addresses, the next address in the data path, and a cost to reach the destination network. There are two kinds of routing protocols on intranet networks, distance vector and link state.

- Distance vector is based on hop count. This is the number of switches that a frame passes through to get from the source switch to the destination switch.
- Link state is based on a metric value based on a cost. The cost could be based on bandwidth, line speed, or round-trip time.

With the link state protocol, switches that discover a route identify the networks to which they are attached, receiving an initial route table from the principal switch. After an initial message is sent out, the switch only notifies the others when changes occur.

It is recommended that no more than seven hops occur between any two switches. This limit is not required or enforced by Fabric Shortest Path First (FSPF). Its purpose is to ensure that a frame is not delivered to a destination after the Resource Allocation TimeOut Value (R\_A\_TOV) has expired.

Fabric OS supports unicast Class 2 and Class 3 traffic, multicast, and broadcast traffic. Broadcast and multicast are supported in Class 3 only.

### NOTE

Routed edge-core-edge EX\_Ports can only be used in the base switch. Other logical switch constitutes in a backbone routed base fabric cannot be in a default switch even though they are not in the routed traffic path.

## Paths and route selection

Paths are possible ways to get from one switch to another. Each inter-switch link (ISL) has a metric cost based on bandwidth. The cumulative cost is based on the sum of all costs of all traversed ISLs.

Route selection is the path that is chosen. Paths that are selected from the routing database are chosen based on the minimal cost.

## FSPF

Fabric Shortest Path First (FSPF) is a link state path selection protocol that directs traffic along the shortest path between the source and destination based upon the link cost. FSPF is also referred to as Layer 2 routing. FSPF detects link failures, determines the shortest route for traffic, updates the routing table, provides fixed routing paths within a fabric, and maintains correct ordering of frames. FSPF

also keeps track of the state of the links on all switches in the fabric and associates a cost with each link. The protocol computes paths from a switch to all the other switches in the fabric by adding the cost of all links traversed by the path, and chooses the path that minimizes the costs. This collection of the link states, including costs, of all the switches in the fabric constitutes the topology database or link state database.

Once established, FSPF programs the hardware routing tables for all active ports on the switch. FSPF is not involved in frame switching. FSPF uses several frames to perform its functions. Because it may run before fabric routing is set up, FSPF does not use the routing tables to propagate the frames, but floods the frames throughout the fabric hop-by-hop. Frames are first flooded on all the ISLs; as the protocol progresses, it builds a spanning tree rooted on the principal switch. Frames are only sent on the principal ISLs that belong to the spanning tree. When there are multiple ISLs between switches, the first ISL to respond to connection requests becomes the principal ISL. Only one ISL from each switch is used as the principal ISL.

The following figure shows the thick red lines as principal ISLs, and thin green lines as regular ISLs.

**FIGURE 5** Principal ISLs

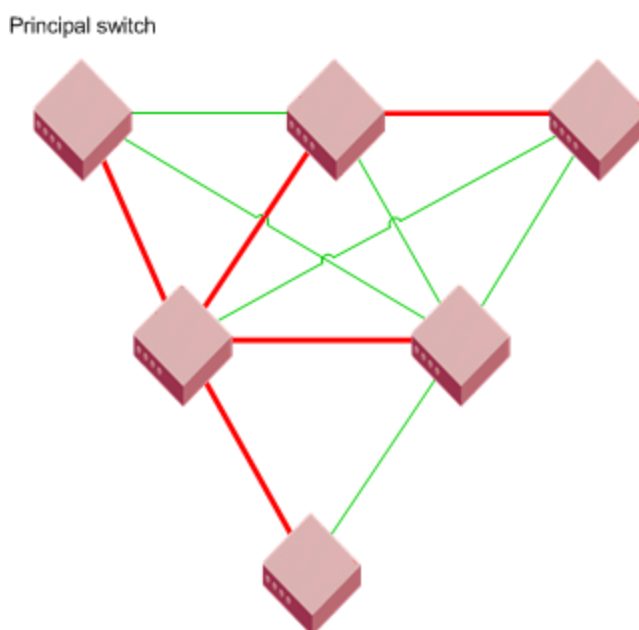

#### NOTE

FSPF only supports 16 routes in a zone, including Traffic Isolation Zones.

FSPF makes minimal use of the ISL bandwidth, leaving virtually all of it available for traffic. In a stable fabric, a switch transmits 64 bytes every 20 seconds in each direction. FSPF frames have the highest priority in the fabric. This guarantees that a control frame is not delayed by user data and that FSPF routing decisions occur very quickly during convergence.

FSPF guarantees a routing loop-free topology at all times. It is essential for a fabric to include many physical loops because, without loops, there would not be multiple paths between switches, and consequently no redundancy. Without redundancy, if a link goes down, part of the fabric is isolated. FSPF ensures both that the topology is loop-free and that a frame is never forwarded over the same ISL more than once.

FSPF calculates paths based on the destination domain ID. The fabric protocol must complete domain ID assignments before routing can begin. ISLs provide the physical pathway when the Source ID (SID) address has a frame destined to a port on a remote switch



Destination ID (DID). When an ISL is attached or removed from a switch, FSPF updates the route tables to reflect the addition or deletion of the new routes.

As each host transmits a frame to the switch, the switch reads the SID and DID in the frame header. If the domain ID of the destination address is the same as the switch (intra-switch communications), the frame buffer is copied to the destination port and a credit R\_RDY message is sent to the host. The switch only needs to read word zero and word one of the Fibre Channel frame to perform what is known as *cut-through routing*. A frame may begin to emerge from the output port before it has been entirely received by the input port. The entire frame does not need to be buffered in the switch.

If the destination domain ID is different from the source domain ID, then the switch consults the FSPF route table to identify which local E\_Port provides Fabric Shortest Path First (FSPF) to the remote domain.

## Fibre Channel NAT

Within an edge fabric or across a backbone fabric, the standard Fibre Channel FSPF protocol determines how frames are routed from the source Fibre Channel (FC) device to the destination FC device. The source or destination device can be a proxy device.

Fibre Channel fabrics require that all ports be identified by a unique port identifier (PID). In a single fabric, FC protocol guarantees that domain IDs are unique, and so a PID formed by a domain ID and area ID is unique within a fabric. However, the domain IDs and PIDs in one fabric may be duplicated within another fabric, just as IP addresses that are unique to one private network are likely to be duplicated within another private network.

In an IP network, a network router can maintain network address translation (NAT) tables to replace private network addresses with public addresses when a packet is routed out of the private network, and to replace public addresses with private addresses when a packet is routed from the public network to the private network. The Fibre Channel routing equivalent to this IP-NAT is Fibre Channel network address translation (FC-NAT). Using FC-NAT, the proxy devices in a fabric can have PIDs that are different from the real devices they represent, allowing the proxy devices to have appropriate PIDs for the address space of their corresponding fabric.

## Inter-switch links

An inter-switch link (ISL) is a link between two switches, E\_Port-to-E\_Port. The ports of the two switches automatically come online as E\_Ports once the login process finishes successfully. For more information on the login process, refer to [Understanding Fibre Channel Services](#) on page 25.

You can expand your fabric by connecting new switches to existing switches. [Figure 6](#) shows a new switch being added into an existing fabric. The thick red line is the newly formed ISL.

FIGURE 6 New switch added to existing fabric

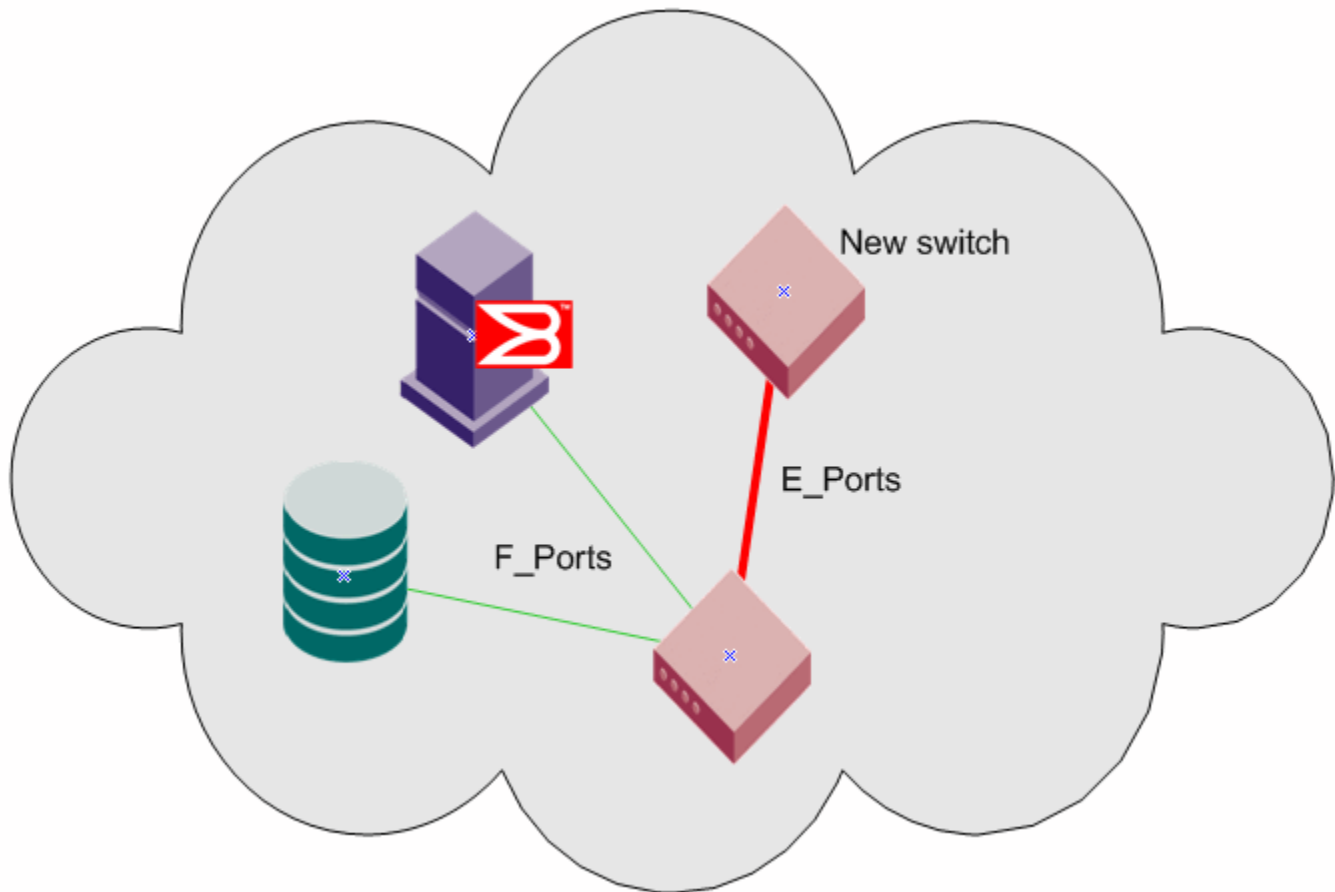

When connecting two switches together, Brocade recommends the best practice that the following parameters are differentiated:

- Domain ID
- Switch name
- Chassis name

You must also verify the following fabric parameters are identical on each switch for a fabric to merge:

- R\_A\_TOV (Resource Allocation TimeOut Value)
- E\_D\_TOV (Error Detect TimeOut Value)
- Data Field Size
- Sequence Level Switching
- Disable Device Probing
- Suppress Class F Traffic
- Per-frame Route Priority

There are non-fabric parameters that must match as well, such as zoning. Some fabric services, such as management server, must match. If the fabric service is enabled in the fabric, then the switch you are introducing into the fabric must also have it enabled. If you experience a segmented fabric, refer to the *Fabric OS Troubleshooting and Diagnostics Guide* to fix the problem.

## Buffer credits

In order to prevent the dropping of frames in the fabric, a device can never send frames without the receiving device being able to receive them, so an end-to-end flow control is used on the switch. Flow control in Fibre Channel uses buffer-to-buffer credits, which are distributed by the switch. When all buffer-to-buffer credits are utilized, a device waits for a VC\_RDY or an R\_RDY primitive from the destination switch before resuming I/O. The primitive is dependent on whether you have R\_RDYs enabled on your switch using the `portCfgISLMode` command. When a device logs in to a fabric, it typically requests from two to sixteen buffer credits from the switch, depending on the device type, driver version, and configuration. This determines the maximum number of frames the port can transmit before receiving an acknowledgement from the receiving device.

For more information on how to set the buffer-to-buffer credits on an extended link, refer to [Buffer-to-Buffer Credits and Credit Recovery](#) on page 127.

## Congestion versus over-subscription

Congestion occurs when a channel is bottlenecked and fully utilized. This kind of bottleneck is a congestion bottleneck. You should be aware that "over-subscription" does not have the same meaning as "congestion". Over-subscription refers only to the potential for congestion; an over-subscribed link may go through a lifetime of normal operation and never be congested. The term over-subscription is not to be used in place of congestion, which is the actual contention for bandwidth by devices through an ISL.

## Virtual channels

Virtual channels create multiple logical data paths across a single physical link or connection. They are allocated their own network resources such as queues and buffer-to-buffer credits. Virtual channel technology is the fundamental building block used to construct Adaptive Networking services. For more information on Adaptive Networking services, refer to [Optimizing Fabric Behavior](#) on page 387.

Virtual channels are divided into three priority groups. P1 is the highest priority, which is used for Class F, F\_RJT, and ACK traffic. P2 is the next highest priority, which is used for data frames. The data virtual channels can be further prioritized to provide higher levels of Quality of Service. P3 is the lowest priority and is used for broadcast and multicast traffic. This example is illustrated in [Figure 7](#).

Quality of Service (QoS) is a licensed traffic shaping feature available in Fabric OS. QoS allows the prioritization of data traffic based on the SID and DID of each frame. Through the use of QoS zones, traffic can be divided into three priorities: high, medium, and low, as shown in [Figure 7](#). The seven data virtual channels (VC8 through VC14) are used to multiplex data frames based upon QoS zones when congestion occurs. For more information on QoS zones, refer to [Optimizing Fabric Behavior](#) on page 387.

FIGURE 7 Virtual channels on a QoS-enabled ISL

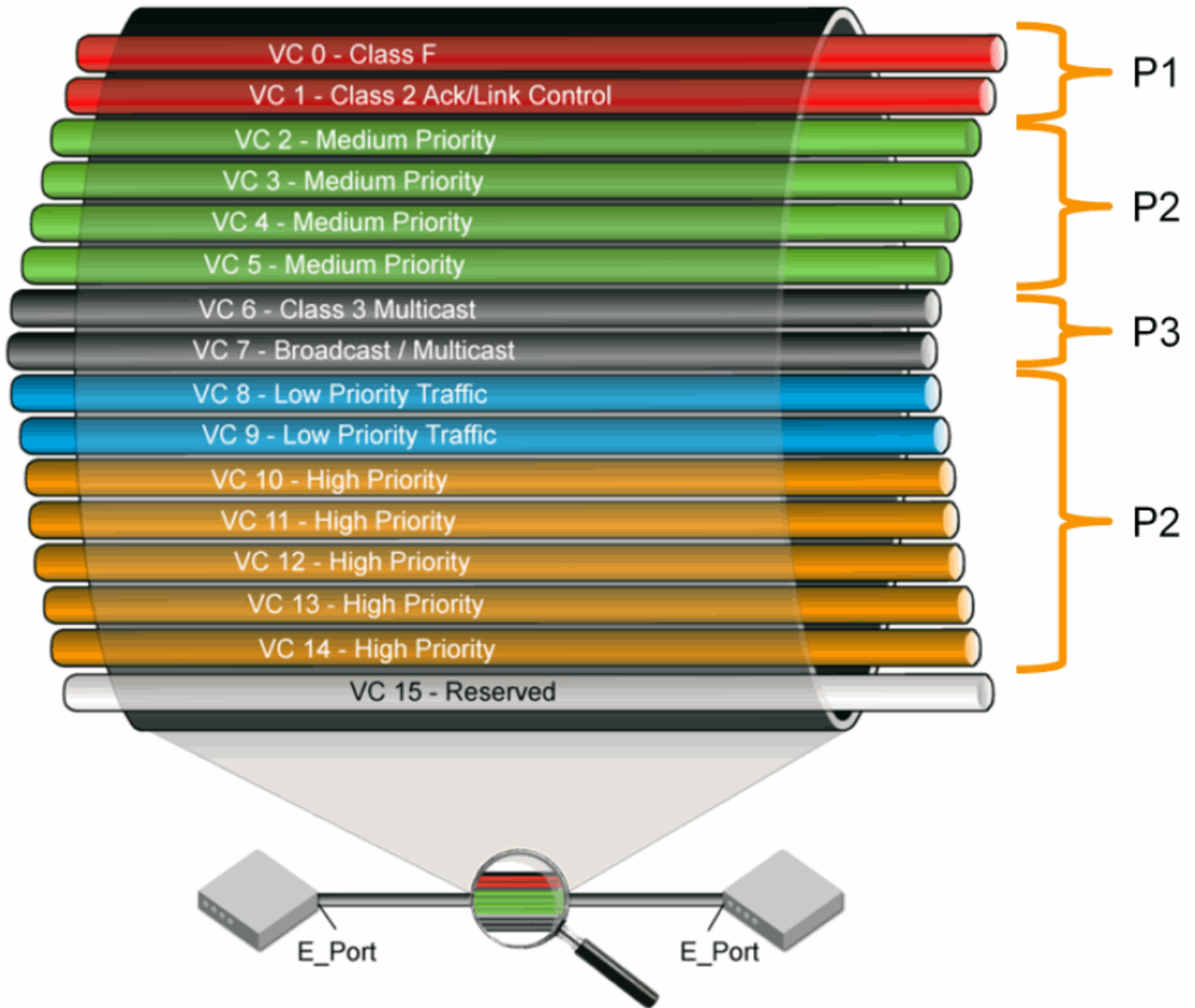

## Gateway links

A gateway merges SANs into a single fabric by establishing point-to-point E\_Port connectivity between two Fibre Channel switches that are separated by a network with a protocol such as IP or SONET.

Except for link initialization, gateways are transparent to switches; the gateway simply provides E\_Port connectivity from one switch to another. The following figure shows two separate SANs, A-1 and A-2, merged together using a gateway.

FIGURE 8 Gateway link merging SANs

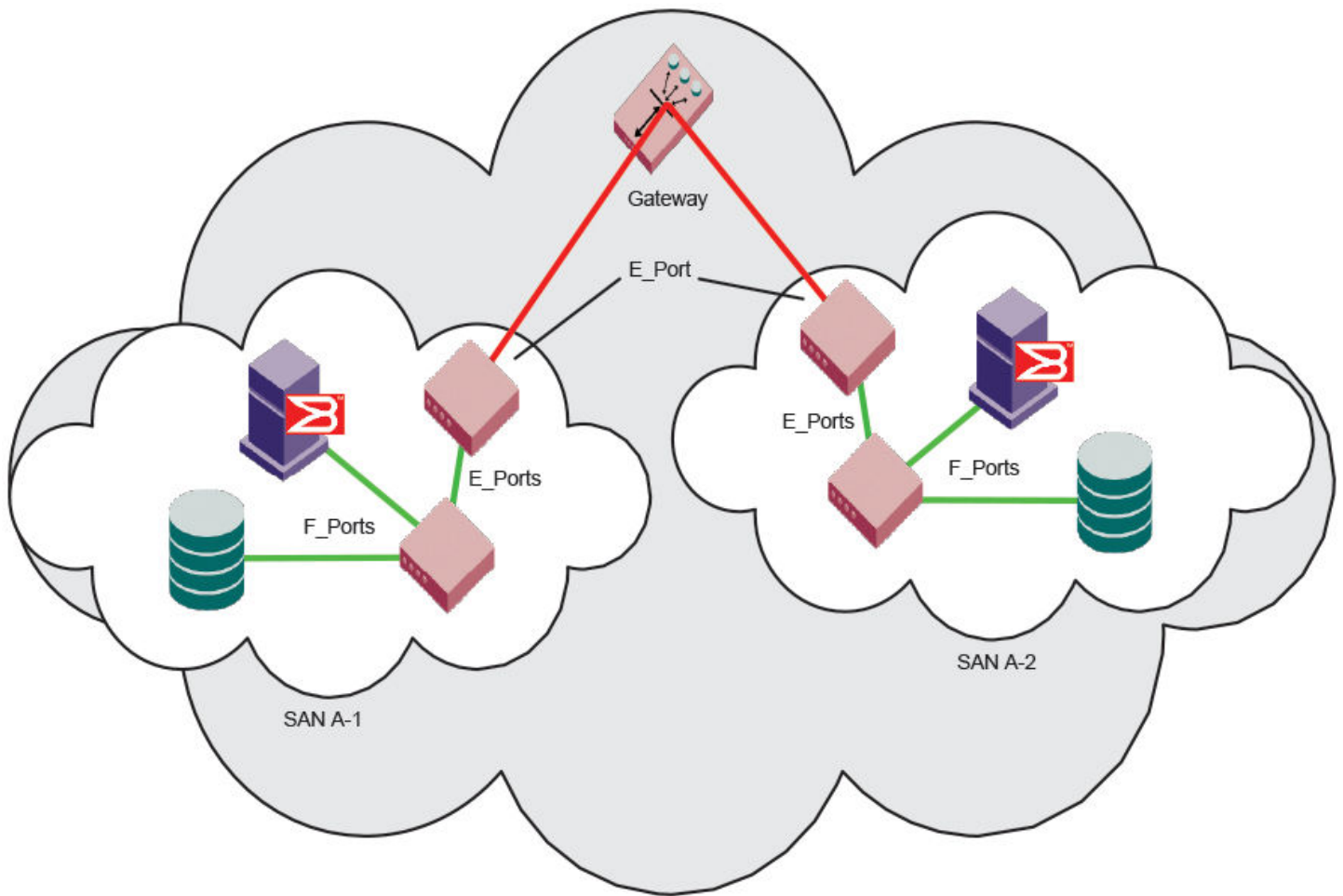

By default, switch ports initialize links using the Exchange Link Parameters (ELP) mode 1. However, gateways expect initialization with ELP mode 2, also referred to as ISL R\_RDY mode. Therefore, to enable two switches to link through a gateway, the ports on both switches must be set for ELP mode 2.

Any number of E\_Ports in a fabric can be configured for gateway links, provided the following guidelines are followed:

- All switches in the fabric use the core PID format, as described in [Configuring a link through a gateway](#) on page 113.
- The switches connected to both sides of the gateway are included when determining switch-count maximums.
- Extended links (those created using the Extended Fabrics licensed feature) are not supported through gateway links.

## Configuring a link through a gateway

1. Connect to the switch at one end of the gateway and log in using an account assigned to the admin role.
2. Enter the `portCfgISLMode` command.
3. Repeat step 1 and step 2 for any additional ports that are connected to the gateway.
4. Repeat this procedure on the switch at the other end of the gateway.

Example of enabling a gateway link on slot 2, port 3:

```
ecp:admin> portcfgislmode 2/3, 1

Committing configuration...done.
ISL R_RDY Mode is enabled for port 3. Please make sure the PID
formats are consistent across the entire fabric.
```

## Routing policies

By default, all routing protocols place their routes into a routing table. You can control the routes that a protocol places into each table and the routes from that table that the protocol advertises by defining one or more routing policies and then applying them to the specific routing protocol.

The routing policy is responsible for selecting a route based on one of three user-selected routing policies:

- Port-based routing
- Exchange-based routing
- Device-based routing

## Notes

Routing is handled by the FSPF protocol and routing policy.

Each switch can have its own routing policy and different policies can exist in the same fabric.

### ATTENTION

For most configurations, the default routing policy is optimal and provides the best performance. You should change the routing policy only if there is a significant performance issue, or a particular fabric configuration or application requires it.

## Displaying the current routing policy

1. Connect to the switch and log in using an account with admin permissions.
2. Enter the **aptPolicy** command with no parameters.

The current policy is displayed, followed by the supported policies for the switch.

In the following example, the current policy is device-based routing (2).

```
switch:admin> aptpolicy

Current Policy: 2
3 : Default Policy
1: Port Based Routing Policy
2: Device Based Routing Policy (FICON support only)
3: Exchange Based Routing Policy
```

## Port-based routing

The choice of routing path is based only on the incoming port and the destination domain. To optimize port-based routing, Dynamic Load Sharing (DLS) can be enabled to balance the load across the available output ports within a domain.

**NOTE**

**For FC routers only:** When an FC router is in port-based routing mode, the backbone traffic is load-balanced based on SID and DID. When an FC router is in exchange-based routing mode, the backbone traffic is load-balanced based on SID, DID, and OXID.

Whatever routing policy a switch is using applies to the VE\_Ports as well. For more information on VE\_Ports, refer to the *Fabric OS FCIP Administrator's Guide*.

## Exchange-based routing

The choice of routing path is based on the Source ID (SID), Destination ID (DID), and Fibre Channel originator exchange ID (OXID) optimizing path utilization for the best performance. Thus, every exchange can take a different path through the fabric. Exchange-based routing requires the use of the Dynamic Load Sharing (DLS) feature; when this policy is in effect, you cannot disable the DLS feature.

Exchange-based routing is also known as Dynamic Path Selection (DPS). For more information on DPS refer to [Dynamic Path Selection](#) on page 115.

## Device-based routing

Device-based routing optimizes routing path selection and utilization based on the Source ID (SID) and Destination ID (DID) of the path source and destination ports. As a result, every distinct flow in the fabric can take a different path through the fabric. Effectively, device-based routing works the same as exchange-based routing but does not use the OXID field. This helps to ensure that the exchanges between a pair of devices stay in order.

**NOTE**

Device-based routing requires the use of Dynamic Load Sharing (DLS); when this policy is in effect, you cannot disable the DLS feature.

Device-based routing is also a form of Dynamic Path Selection (DPS). For more information on DPS refer to [Dynamic Path Selection](#) on page 115.

**NOTE**

Device-based routing is supported in FICON environments, and in open environments only when FICON coexists.

## Dynamic Path Selection

DPS assigns communication paths between end devices in a fabric to egress ports in ratios proportional to the potential bandwidth of the ISL, ICL, or trunk group. When there are multiple paths to a destination, the input traffic is distributed across the different paths in proportion to the bandwidth available on each of the paths. This improves utilization of the available paths, thus reducing possible congestion on the paths. Every time there is a change in the network (which changes the available paths), the input traffic can be redistributed across the available paths. This is a very easy and non-disruptive process when the exchange-based routing policy is engaged.

## Displaying a dynamic path selection group for reachable domains

You can use the **portChannelShow** command to display a dynamic path selection group for one or all reachable domains.

- Use the **portChannelShow** command to display the port channels from a domain to all the reachable domains on the switch. For example,

```
switch:admin> /fabos/cliexec/portchannelshow
6 domain(s) in the fabric; Local Domain ID: 4
```

```

Domain:    1
Name:      sw0
WWN:      10:00:00:05:33:c1:26:00
Port Channel:  None

Domain:    2
Name:      DCX_35_F_128
WWN:      10:00:00:05:1e:38:e5:23
Port Channel:
  Ports:   384, 385, 386, 387, 400, 401, 402, 403,
           417, 418, 419, 432, 433, 434, 435

Domain:    3
Name:      SW_122_F_128
WWN:      10:00:00:05:1e:9b:10:5b
Port Channel:
  Ports:   111, 248

Domain:    5
Name:      SW_65_F128
WWN:      10:00:00:05:1e:5c:f6:fd
Port Channel:
  Ports:   384, 385, 386, 387, 400, 401, 402, 403,
           417, 418, 419, 432, 433, 434, 435

Domain:    6
Name:      SW_121_F_128
WWN:      10:00:00:05:1e:9c:32:cc
Port Channel:  None

```

- Use the `portChannelShow [remote-domain-id / switch-name / switch-WWN]` command to display the port channels from the switch where this command is executed to the specified switch or domain. For example,

```

switch:admin> /fabos/cliexec/portchannelshow 2 (OR)
switch:admin> /fabos/cliexec/portchannelshow 10:00:00:05:1e:38:e5:23 (OR)
switch:admin> /fabos/cliexec/portchannelshow DCX_35_F_128

Domain:    2
Name:      DCX_35_F_128
WWN:      10:00:00:05:1e:38:e5:23
Port Channel:
  Ports:   384, 385, 386, 387, 400, 401, 402, 403,
           417, 418, 419, 432, 433, 434, 435

```

## Route selection

Selection of specific routes can be dynamic, so that the router can constantly adjust to changing network conditions; or it may be static, so that data packets always follow a predetermined path.

## Dynamic Load Sharing

The Fabric OS Dynamic Load Sharing (DLS) feature for dynamic routing path selection is required by the exchange-based and device-based routing policies. When using these policies, DLS is enabled by default and cannot be disabled. In other words, you cannot enable or disable DLS when the exchange-based routing policy is in effect.

When the port-based policy is in force, you can enable DLS to optimize routing. When DLS is enabled, it shares traffic among multiple equivalent paths between switches. DLS recomputes load sharing when any of the following occurs:

- A switch boots up
- An E\_Port goes offline and online
- An EX\_Port goes offline



- A device goes offline

## Setting DLS

Use the following procedure to set DLS.

1. Connect to the switch and log in using an account with admin permissions.
2. Enter the **dlsShow** command to view the current DLS setting.

One of the following messages appears:

- "DLS is set with Lossless disabled" indicates that DLS is turned on.
- "DLS is not set with Lossless disabled" indicates that DLS is turned off.
- "DLS is set with Lossless enabled." DLS is enabled with the Lossless feature. Load sharing is recomputed with every change in the fabric, and existing routes can be moved to maintain optimal balance. In Lossless mode, no frames are lost during this operation.
- Refer to the *Fabric OS Command Reference* for more details.

3. Enter the **dlsSet** command to enable DLS or enter the **dlsReset** command to disable it.

Example of setting and resetting DLS

```
switch:admin> dlsshow
DLS is not set with Lossless disabled

switch:admin> dlsset
switch:admin> dlsshow
DLS is set with Lossless disabled

switch:admin> dlsreset
switch:admin> dlsshow
DLS is not set with Lossless disabled
```

## Frame order delivery

The order in which frames are delivered is maintained within a switch and determined by the routing policy in effect. The frame delivery behaviors for each routing policy are:

- Port-based routing
 

All frames received on an incoming port destined for a destination domain are guaranteed to exit the switch in the same order in which they were received.
- Exchange-based routing
 

All frames received on an incoming port for a given exchange are guaranteed to exit the switch in the same order in which they were received. Because different paths are chosen for different exchanges, this policy does not maintain the order of frames across exchanges.
- Device-based routing
 

All frames received on an incoming port for a given pair of devices are guaranteed to exit the switch in the same order in which they were received.

If even one switch in the fabric delivers out-of-order exchanges, then exchanges are delivered to the target out of order, regardless of the policy configured on other switches in the fabric.

### NOTE

Some devices do not tolerate out-of-order exchanges; in such cases, use the port-based routing policy.

In a stable fabric, frames are always delivered in order, even when the traffic between switches is shared among multiple paths. However, when topology changes occur in the fabric (for example, if a link goes down), traffic is rerouted around the failure, and some frames could be delivered out of order. Most destination devices tolerate out-of-order delivery, but some do not.

By default, out-of-order frame-based delivery is allowed to minimize the number of frames dropped. Enabling in-order delivery (IOD) guarantees that frames are either delivered in order or dropped. You should only force in-order frame delivery across topology changes if the fabric contains destination devices that cannot tolerate occasional out-of-order frame delivery.

## Forcing in-order frame delivery across topology changes

Use the following procedure to force in-order frame delivery across topology changes.

1. Connect to the switch and log in using an account with admin permissions.
2. Enter the **iodSet** command.

### NOTE

The **iodSet** command can cause a delay in the establishment of a new path when a topology change occurs; use it with care.

3. Confirm the in-order delivery has been set by entering the **iodShow** command.

## Restoring out-of-order frame delivery across topology changes

Use the following procedure to restore out-of-order frame delivery across topology changes.

1. Connect to the switch and log in using an account with admin permissions.
2. Enter the **iodReset** command.

## Enabling Frame Viewer

The Frame Viewer application allows you to view the contents of discarded frames, which can be recorded at up to 40 frames per second per ASIC.

To enable Frame Viewer, complete the following steps.

1. Connect to the switch and log in using an account with admin permissions.
2. Enter **frameLog --enable -type *type***.

The following table lists the supported values for *type*. If the **-type** option is not provided, then all three discard frame types will be recorded.

Option	Description
timeout	Due to timeout.
du	Due to destination unreachable.
unroute	Due to unrouteable frame.

3. Use the **frameLog --status** command to view the configuration. The following is a typical example of the output of this command:

```
switch:admin> framelog --status
Service Status:           Enabled
Enabled Disc Frame Types:  timeout unroute
```

**NOTE**

Frame viewing for unroutable and "destination unreachable" frames is supported only on the following devices:

- Brocade 6505, 6510, 6520, G620, DCX 8510-4, DCX 8510-8, X6-4 and X6-8 switches.
- Brocade CR32-4, CR32-8, CR16-4, CR16-8, FC32-48, FC16-32, FC16-48, and FC16-64 blades. If a chassis has any older blades, only the timeout frames will be captured for those blades.

## Using Frame Viewer to understand why frames are dropped

When a frame is unable to reach its destination because of a timeout, is unroutable, or has an unreachable destination, it is discarded. You can use Frame Viewer to find out which flows contained the dropped frames, which in turn can help you determine the applications that might be impacted. Frame Viewer allows you to see the exact time (within one second) that the frames were dropped.

You can view up to 40 discarded frames per ASIC per second for 1200 seconds with the **frameLog** command. You filter this view using a number of fields to filter this output so you are viewing only those frames you are concerned with.

To display information about discarded frames, complete the following steps. This assumes that the **framelog** application has been enabled previously.

1. Connect to the switch and log in using an account with admin permissions.
2. Enter **frameLog --show**.

Refer to the *Fabric OS Command Reference* for additional information on using the **frameLog** command, including resetting (clearing) the frame log.

The following example shows a typical output of the **frameLog --show** command:

```
switch:admin> framelog --show
=====
Fri Jul 13 23:47:08 UTC 2012
=====
Log
timestamp      TX      RX
port          port
SID            DID      SFID    DFID    Type      Count
=====
Jul 13 23:47:07 11/45 11/45 0xfffffd 0x40e580 0      0      timeout    2
Jul 13 23:47:07 11/45 11/45 0xfffffc 0x40e580 0      0      timeout    5
Jul 13 23:47:07 11/45 11/45 0xfffffc 0x40e580 0      0      timeout    3
Jul 13 23:47:07 11/45 11/45 0xfffc40 0x40e580 0      0      timeout    2
Jul 13 23:47:07 11/45 11/45 0xfffc40 0x40e580 0      0      timeout    1
Jul 13 23:47:08 --      3      0x050300 0x0a1600 128    128    unroute    9
Jul 13 23:47:08 --      1      0x050100 0x0a1600 128    128    unroute    11
Jul 13 23:47:08 --      0      0x050000 0x012000 128    128    du         20
Jul 13 23:47:08 --      34     0x050400 0x020200 128    128    unroute    1
```

**NOTE**

There may occasionally be frame types listed as "unknown" in the output; these are usually frames that have been corrupted in transit, and so the **frameLog** command cannot identify their type.

## Displaying discarded frames by back-end port in Frame Viewer

When viewing information about discarded frames, you can filter the results by specifying that the TX port or RX port of displayed frames should be a back-end port.

Individual back-end ports cannot be specified, only the quality of being a back-end port can be specified.

1. Connect to the switch and log in using an account with admin permissions.
2. Use the **frameLog --show** command, followed by **-txport**, **-rxport**, or both, and specifying **-1** for the port number.

```
switch:admin> framelog --show -txport -1 -rxport -1
```

Specify `-1` for fixed-port switches and `-1/-1` for Brocade Backbones. These indicate “any back-end port”.

#### NOTE

Frame discards can be logged as audit messages using the Fabric OS syslog facility.

## Lossless Dynamic Load Sharing on ports

Lossless Dynamic Load Sharing (DLS) allows you to rebalance port paths without causing input/output (I/O) failures. For devices where in-order delivery (IOD) of frames is required, you can set IOD separately. You can use this feature with the following hardware:

- Brocade 6505
- Brocade 6510
- Brocade 6520
- Brocade G620
- Brocade M6505 blade server SAN I/O module
- Brocade 6543 blade server SAN I/O module
- Brocade 6545 blade server SAN I/O module
- Brocade 6546 blade server SAN I/O module
- Brocade 6547 blade server SAN I/O module
- Brocade 6548 blade server SAN I/O module
- Brocade 6558 blade server SAN I/O module
- Brocade DCX 8510 Directors with the following blades:
  - Brocade FC16-32, FC16-48, FC16-64 port blades
- Brocade X6 Directors with the following blades:
  - Brocade FC32-48 port blades

Lossless DLS must be implemented along the path between the target and the initiator. You can use Lossless DLS on ports connecting switches to perform the following functions:

- Eliminate dropped frames and I/O failures by rebalancing the paths going over the ISLs whenever there is a fabric event that might result in suboptimal utilization of the ISLs.
- Eliminate the frame delay caused by establishing a new path when a topology change occurs.

Lossless mode means no frame loss during a rebalance and only takes effect if DLS is enabled. Lossless DLS can be enabled on a fabric topology to have zero frame drops during rebalance operations. If the end device also requires the order of frames to be maintained during the rebalance operation, then IOD must be enabled. However, this combination of Lossless DLS and IOD is supported only in specific topologies, such as in a FICON environment.

You can disable or enable IOD when Lossless DLS is enabled. You can also choose between exchange- or port-based policies with Lossless DLS. The following events cause a rebalance:

- Adding a redundant E\_Port
- Adding a slave E\_Port
- Removing the last E\_Port from a neighbor domain (However, frame loss occurs on traffic flows to this port.)
- Removing an F\_Port (However, frame loss occurs on traffic flows to this port.)

Lossless DLS does the following whenever paths need to be rebalanced:

1. Pauses ingress traffic by not returning credits. Frames that are already in transit are not dropped.

2. Applies the results of the rebalance calculations.
3. *If IOD is enabled*, waits for sufficient time for frames already received to be transmitted. This is needed to maintain IOD.
4. Resumes traffic.

The following table shows the effect of frames when you have a specific routing policy turned on with IOD.

**TABLE 11** Combinations of routing policy and IOD with Lossless DLS enabled

Policy	IOD	Rebalance result with Lossless DLS enabled
Port-based	Disabled	No frame loss, but out-of-order frames may occur.
Port-based	Enabled	No frame loss and no out-of-order frames. Topology restrictions apply. Intended for FICON environment.
Exchange-based	Disabled	No frame loss, but out-of-order frames may occur.
Exchange-based	Enabled	No frame loss and no out-of-order frames. Topology restrictions apply. Intended for FICON environment.
Device-based	Disabled	No frame loss, but out-of-order frames may occur.
Device-based	Enabled	No frame loss and no out-of-order frames. Topology restrictions apply. Intended for FICON environment.

#### NOTE

Not only the link cost has influence on DLS, but the order of ports that become online and the speeds of each E\_Port or F\_Port also have an impact on how the switch calculates or chooses the path using DLS.

## Lossless core

Lossless core works with the default configuration of the Brocade DCX 8510 Backbones and X6 Directors to prevent frame loss during a core blade removal and insertion. This feature is on by default and cannot be disabled. Lossless core has the following limitations:

- Only supported with IOD disabled, which means Lossless core cannot guarantee in-order delivery of exchanges
- ICL limitations
- Traffic flow limitations

## ICL limitations

If ICL ports are connected during a core blade removal, it is equivalent to removing external E\_Ports which may cause I/O disruption on the ICL ports that have been removed.

If ICL ports are connected during a core blade insertion, it is equivalent to adding external E\_Ports which may cause I/O disruption because of reroutes. Lossless DLS, if enabled, takes effect to prevent I/O disruption.

#### NOTE

Before you replace the core blades, enable lossless so that the **portDecom** can decommission the E\_Ports losslessly and bring up the E\_Ports back losslessly.

## Configuring Lossless Dynamic Load Sharing

You can configure Lossless DLS on either a switch- or chassis-wide basis by using the **dlsSet** command to specify that no frames are dropped while rebalancing or rerouting traffic.

#### NOTE

For more information regarding DLS or E\_Port balancing, refer to the **dlsset** command in the *Fabric OS Command Reference*.

To configure Lossless Dynamic Load Sharing, complete the following steps.

1. Connect to the switch and log in using an account with admin permissions.
2. Enter the appropriate **dlSet** command to enable or disable Lossless Dynamic Load Sharing.

```
switch:admin> dlset --enable -lossless
switch:admin> dlset --disable -lossless
```

#### NOTE

To enable lossless on the whole chassis when multiple logical switches exist, you must enable lossless on each logical switch independently or use the **fosexec --fid all -cmd dlset** command.

## Lossless Dynamic Load Sharing in Virtual Fabrics

Enabling Lossless Dynamic Load Sharing is optional on logical switches in Virtual Fabrics. If you enable this feature, it must be on a per-logical switch basis and can affect other logical switches in the fabric.

### How DLS affects other logical switches in the fabric

On a Brocade DCX 8510 platform, logical switch 1 consists of ports 0 through 5 in slot 1. Logical switch 2 consists of ports 6 through 10 in slot 1. The Lossless DLS feature is enabled on logical switch 1. Because ports 0 through 5 in slot 1 belong to a logical switch where Lossless DLS is enabled, the traffic in logical switch 2 is affected whenever traffic for logical switch 1 is rebalanced.

#### ATTENTION

Although Lossless DLS is enabled for a specific logical switch, you must have chassis-level permissions to use this feature.

The effect on logical switch 2 is based on the configuration on logical switch 2:

- If logical switch 2 has IOD enabled (**iodSet** only), IOD is enforced.
- If logical switch 2 has Lossless DLS enabled, traffic is paused and resumed.
- If logical switch 2 has no IOD (**iodReset**), traffic is paused and resumed.

To avoid this behavior, it is recommended to define your logical switches as follows:

- Define logical switches that require Lossless DLS at the blade boundary.
- Define logical switches that require Lossless DLS only using supported blades. For example, do not use blades that support IOD, but do not support Lossless DLS.

For more information on Virtual Fabrics and chassis-level permissions, refer to [Managing Virtual Fabrics](#) on page 267.

## Two-hop Lossless DLS route update

Certain fabric topology changes may affect the Shortest Path First results that lead to rebalance operations, and thus change the paths utilized. During these rebalance operations, even if the lossless DLS setting is enabled, route updates caused by fabric shortest path changes may result in I/O disruptions and/or out-of-order frame delivery. Route updates are not done globally across all switches at the same time. A new path may be used before the later switches are ready.

Lossless DLS supports rebalance operations after events that affect redundancy within a hop but do not cause fabric shortest path changes. Lossless DLS can only ensure that the local switch updates are performed in the required manner. Lossless DLS cannot ensure that a downstream domain has completed its rebalancing operations prior to a new path being used. The Two-hop enhancement to Lossless DLS extends the lossless route update capabilities to support the addition of a new hop between switches.

When a new link is added between two switches where one was not there previously, the new link is likely to cause changes to the shortest path results. The Two-hop enhancement to Lossless DLS ensures that the route updates happen on the local switches of the

new link prior to the rest of the fabric. For devices on those two switches, when they attempt to start using the new link, Two-hop Lossless DLS ensures that the routes are ready for use prior to their route updates.

For a switch that is directly connected to one of the two switches with the new link, when it performs the rebalance operation, its device traffic is shifted to the new path in a lossless manner. If the new path to which traffic is being shifted to is up to two hops (one of which includes the new link), Two-hop Lossless DLS ensures that the routes along that two-hop path are ready for use.

#### NOTE

If a fabric shortest path that includes the new link is longer than two hops, when the switches perform their rebalancing operations, the traffic may still experience I/O disruptions and/or out-of-order frame delivery.

Once the new hop has been established, all later route updates use the standard lossless DLS capabilities.

- Two-hop Lossless DLS has the same platform and ISL technology restrictions as the Lossless DLS feature.
- Two-hop Lossless DLS is not supported with TI zones due to non-deterministic ordering of events when multiple ISLs come online at the same time.
- Two-hop Lossless DLS is not supported with any hops to or through an FC router related domain (front and translate domains).
- Two-hop Lossless DLS is not supported over logical ISLs (LISLs).
- You must manually enable this feature on all switches to get the desired results.

## Configuring Two-hop Lossless DLS

The **dlsSet** and **dlsShow** commands have been updated to support the new **twohop** option. The **dlsReset** command resets the state of DLS in port-based routing. The state of lossless, two-hop and eportbal are set using the **dlsSet** command. The **dlsSet** command now accepts a new **twohop** option to enable or disable the two-hop lossless DLS feature.

```
sw_79:root> dlsset --help
dlsset usage:
dlsset
dlsset --enable -lossless
dlsset --disable -lossless
dlsset --enable -twohop
dlsset --disable -twohop
dlsset --enable -eportbal
dlsset --disable -eportbal
dlsset --rebalance
dlsset --rebalance -all
```

The **dlsShow** command displays the state of the *Two-hop Lossless DLS* enhancement when it has been enabled. If the enhancement is disabled, the original default output is displayed.

```
sw_79:root> dlsshow
DLS is set with Two-hop Lossless enabled
E_Port Balance Priority is not set
```

## Frame Redirection

Frame Redirection provides a means to redirect traffic flow between a host and a target that use virtualization and encryption applications, such as the Brocade SAS blade and Brocade Data Migration Manager (DMM), so that those applications can perform without having to reconfigure the host and target. You can use this feature if the hosts and targets are not directly attached.

Frame Redirection depends on the wide distribution of the Defined Zone Database. The Defined Zone Database on Fabric OS switches is pushed out to all other Fabric OS switches in the fabric that support Frame Redirection. Redirection zones exist only in the defined configuration and cannot be added to the effective configuration.

**NOTE**

Fabric OS v7.2.0 is not supported on the Brocade 7600 or Brocade SAS blade. However, this hardware can run in a pre-Fabric OS v7.2.0 system and attach to a Fabric OS v7.2.0 fabric.

Frame Redirection uses a combination of special frame redirection zones and name server changes to spoof the mapping of real device WWNs to virtual PIDs.

**FIGURE 9** Single host and target

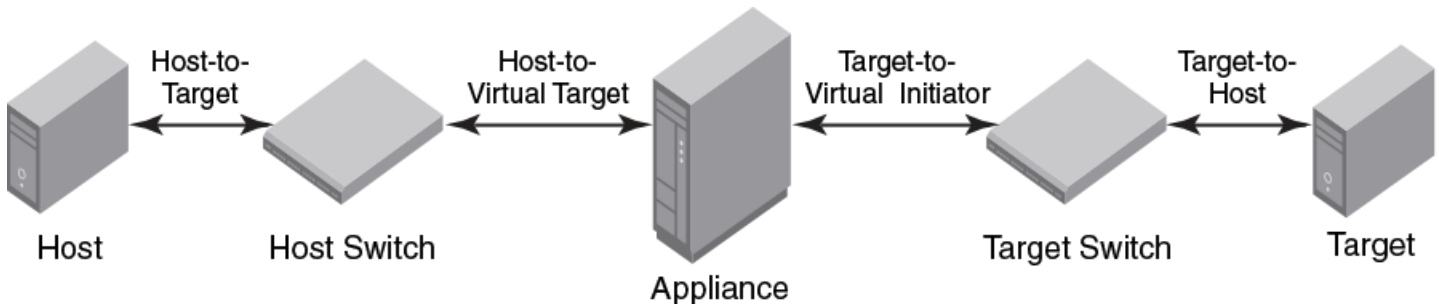

Figure 9 demonstrates the flow of Frame Redirection traffic. A frame starts at the host with a destination to the target. The port where the appliance is attached to the host switch acts as the virtual initiator and the port where the appliance is attached to the target switch is the virtual target.

## Creating a frame redirect zone

The first time the **zone --rdcreate** command is run, the following zone objects are created by default:

- The base zone object, "red\_\_\_\_\_base".
- The redirect (RD) zone configuration, "r\_e\_d\_i\_r\_c\_\_fg".

**NOTE**

Frame redirect zones are not supported with D or I initiator target zones.

**ATTENTION**

Prior to creating the frame redirect zone, you must create a Layer 2 zone for the Initiator (host) and Target (storage). This zone must be part of the effective configuration and must be defined using the port World Wide Name (WWN). Refer to [Creating a zone](#) on page 308, and [Enabling a zone configuration](#) on page 322.

Use the following procedure to create a frame redirect zone.

1. Connect to the switch and log in using an account with admin permissions.
2. Enter the **zone --rdcreate** command.
3. Enter the **cfgSave** command to save the frame redirect zones to the defined configuration.

The following example creates a redirect zone, given a host (10:10:10:10:10:10:10:10), target (20:20:20:20:20:20:20:20), virtual initiator (30:30:30:30:30:30:30:30), and virtual target (40:40:40:40:40:40:40:40):

```
switch:admin>zone --rdcreate 10:10:10:10:10:10:10:10 20:20:20:20:20:20:20:20 \
30:30:30:30:30:30:30:30 40:40:40:40:40:40:40:40 restartable noFCR
```



## Deleting a frame redirect zone

Use the following procedure to delete a frame redirect zone.

1. Connect to the switch and log in using an account with admin permissions.
2. Enter the **zone --rddelete** command to remove the base redirect zone object, "red\_\_\_\_\_base".

### NOTE

When the base zone is removed, the redirect zone configuration "r\_e\_d\_i\_r\_c\_\_fg" is removed as well.

3. Enter the **cfgSave** command to save changes to the defined configuration.

Example of deleting a frame redirect zone

```
switch:admin> zone --rddelete \  
red_0917_10_10_10_10_10_10_10_20_20_20_20_20_20_20_20
```

## Viewing frame redirect zones

Use the following procedure to view frame redirect zones.

1. Connect to the switch and log in using an account with admin permissions.
2. Enter the **cfgShow** command.



# Buffer-to-Buffer Credits and Credit Recovery

- Buffer credit management .....127
- Buffer credit recovery ..... 139
- Credit loss detection..... 141

## Buffer credit management

Buffer-to-buffer credit management affects performance over distances; therefore, allocating a sufficient number of buffer credits for long-distance traffic is essential to performance.

To prevent a target device (either host or storage) from being overwhelmed with frames, the Fibre Channel architecture provides flow control mechanisms based on a system of credits. Each of these credits represents the ability of the device to accept additional frames. If a recipient issues no credits to the sender, no frames can be sent. Pacing the transport of subsequent frames on the basis of this credit system helps prevent the loss of frames and reduces the frequency of entire Fibre Channel sequences needing to be retransmitted across the link.

Because the number of buffer credits available for use within each port group is limited, configuring buffer credits for extended links may affect the performance of the other ports in the group used for core-to-edge connections. You must balance the number of long-distance ISL connections and core-to-edge ISL connections within a switch.

### NOTE

Configuring long-distance ISLs between core and edge switches is possible, but is not a recommended practice.

All switch ports provide protection against buffer depletion through buffer limiting. A buffer-limited port reserves a minimum of eight buffer credits, allowing the port to continue to operate rather than being disabled because of a lack of buffers.

Buffer-limited operations are supported for the static mode (LS) and dynamic mode (LD) extended ISL modes only. For LD, distance in kilometers is the smaller of the distance measured during port initialization versus the *desired\_distance* value. For LS, distance in kilometers is always the *desired\_distance* value.

## Buffer-to-buffer flow control

Buffer-to-buffer (BB) credit flow control is implemented to limit the amount of data that a port may send, and is based on the number and size of the frames sent from that port. Buffer credits represent finite physical-port memory. Within a fabric, each port may have a different number of buffer credits. Within a connection, each side may have a different number of buffer credits.

Buffer-to-buffer flow control is flow control between adjacent ports in the I/O path, for example, transmission control over individual network links. A separate, independent pool of credits is used to manage buffer-to-buffer flow control. A sending port uses its available credit supply and waits to have the credits replenished by the port on the opposite end of the link. These buffer credits are used by Class 2 and Class 3 services and rely on the Fibre Channel Receiver-Ready (R\_RDY) control word to be sent by the receiving link port to the sender. The rate of frame transmission is regulated by the receiving port, and is based on the availability of buffers to hold received frames.

If Virtual Channel technology is in use, the VC\_RDY or EXT\_VC control word is used instead of the R\_RDY control word to manage buffer credits. For Virtual Channels, the buffer credits are managed for each Virtual Channel, and not for the entire physical link.

The Virtual Channels used in VC\_RDY flow-control mode range from VCO through VC7. When QoS is enabled, EXT\_VC\_RDY flow-control mode allocates VCO through VC14. VC8 through VC14 are allocated specifically for QoS VCs.

Upon arriving at a receiver, a frame goes through several steps. It is received, deserialized, and decoded, and is stored in a receive buffer where it is processed by the receiving port. If another frame arrives while the receiver is processing the first frame, a second receive buffer is needed to hold this new frame. Unless the receiver is capable of processing frames as fast as the transmitter is capable of sending them, it is possible for all of the receive buffers to fill up with received frames. At this point, if the transmitter should send another frame, the receiver will not have a receive buffer available and the frame is lost. Buffer-to-buffer flow control provides consistent and reliable frame delivery of information from sender to receiver.

## Optimal buffer credit allocation

The optimal number of buffer credits is determined by the distance (frame delivery time), the processing time at the receiving port, the link signaling rate, and the size of the frames being transmitted. As the link speed increases, the frame delivery time is reduced and the number of buffer credits must be increased to obtain full link utilization, even in a short-distance environment.

For each frame that is transferred, the hardware at the other end must acknowledge that the frame has been received before a successful transmission occurs. This flow requires enough capacity in the hardware to allow continuous transmission of frames on the link, while waiting for the acknowledgment to be sent by the receiver at the other end.

As the distance between switches and the link speed increases, additional buffer credits are required for the ports used for long-distance connections. Distance levels define how buffer credits are allocated and managed for extended ISLs. Buffer credits are managed from a common pool available to a group of ports on a switch. The buffer credit can be changed for specific applications or operating environments, but it must be in agreement among all switches to allow formation of the fabric.

Smaller frame sizes need more buffer credits. Two commands are available to help you determine whether you need to allocate more buffer credits to handle the average frame size. The **portBufferShow** command calculates the average frame size. The **portBufferCalc** command uses the average frame size with the speed and link distance to determine the number of buffer credits needed.

## Considerations for calculating buffer credits

The following are the considerations that you need to follow for calculating the number of ports that can be configured for long distance on all Fabric OS 7.x and later-capable switch modules:

- Each port is part of a port group that includes a pool of buffer credits that can be used. This port group is not the same as the port groups used for ISL Trunking.
- Each user port reserves eight buffer credits when online or offline.
- Any remaining buffers can be reserved by any port in the port group.
- When QoS is enabled and the port is online, additional buffers are allocated to that port. Refer to [Calculating the number of buffers required based on full-size frames](#) on page 130 and [Configuring buffers for a single port directly](#) on page 132 for more information.

## Fibre Channel gigabit values reference definition

The following table shows the Fibre Channel gigabit values that you can use to calculate buffer requirements.

**TABLE 12** Fibre Channel gigabit values

Gigabit value	Line rate
1 Gbps	1.0625
2 Gbps	2.125
4 Gbps	4.25
8 Gbps	8.5
10 Gbps	10.625

**TABLE 12** Fibre Channel gigabit values (continued)

Gigabit value	Line rate
16 Gbps	17
32 Gbps	28.05

## Buffer credit allocation based on full-size frames

Assuming that the frame is a full-size frame, one buffer credit allows a device to send one payload up to 2,112 bytes (2,148 with headers). Assuming that each payload is 2,112, you need one credit per 1 km of link length at 2 Gbps (smaller payloads require additional buffer credits to maintain link utilization). Refer to [Allocating buffer credits based on average-size frames](#) on page 131 for additional information.

## Fibre Channel data frames

The final frame size must be a multiple of 4 bytes. If the data (payload) needs to be segmented, it will be padded with 1 to 3 "fill-bytes" to achieve an overall 4-byte frame alignment. The standard frame header size is 24 bytes. If applications require extensive control information, up to 64 additional bytes (for a total of an 88-byte header) can be included. Because the total frame size cannot exceed the maximum of 2,148 bytes, the additional header bytes will subtract from the data segment by as much as 64 bytes (per frame). This is why the maximum data (payload) size is 2,112 (because  $[2,112 - 64] = 2,048$ , which is 2 kb of data). The final frame, after it is constructed, is passed through the 8-byte-to-10-byte conversion process.

[Table 13](#) describes Fibre Channel data frames.

**TABLE 13** Fibre Channel data frames

Fibre Channel frame fields	Field size	Final frame size
Start of frame	4 bytes	32 bits
Standard frame header	24 bytes	192 bits
Data (payload)	0-2,112 bytes	0-16,896 bits
CRC	4 bytes	32 bits
End of frame	4 bytes	32 bits
Total (number bits/frame)	<b>36-2,148 bytes</b>	<b>288-7,184 bits</b>

## Allocating buffer credits based on full-sized frames

You can allocate buffer credits based on distance using the `portCfgLongDistance` command. The long-distance link modes allow you to select the dynamic mode (LD) or the static mode (LS) to calculate the buffer credits.

For LD, the estimated distance in kilometers is the smaller of the distance measured during port initialization versus the *desired\_distance* parameter, which is required when a port is configured as an LD or an LS mode link. A best practice is to use LS over LD. The assumption that Fibre Channel payloads are consistently 2,112 bytes is not realistic in practice. To gain the proper number of buffer credits with the LS mode, there must be enough buffer credits available in the pool, because Fabric OS will check before accepting a value.

### NOTE

The *desired\_distance* parameter of the `portCfgLongDistance` command's is the upper limit of the link distance and is used to calculate buffer availability for other ports in the same port group. When the measured distance exceeds the value of *desired\_distance*, this value is used to allocate the buffers. In this case, the port operates in degraded mode instead of being disabled as a result of insufficient buffer availability. In LS mode, the actual link distance is not measured; instead, the *desired\_distance* value is used to allocate the buffers required for the port.

Refer to the data in [Table 14](#) on page 135 and [Table 17](#) on page 136 to get the total ports in a switch or blade, the number of user ports in a port group, and the unreserved buffer credits available per port group. The values reflect an estimate, and may differ from the supported values in [Table 17](#) on page 136.

## Calculating the number of buffers required based on full-size frames

Use the following procedure to calculate the number of buffers required for a long-distance connection:

1. Determine the desired distance in kilometers of the switch-to-switch connection.
2. Determine the speed that you will use for the long-distance connection.
3. Use one of the following formulas to calculate the reserved buffers for distance:

- If QoS is enabled:

$$(\text{Reserved\_Buffer\_for\_Distance\_Y}) = (X * \text{LinkSpeed} / 2) + 6 + 14$$

- If QoS is not enabled:

$$(\text{Reserved\_Buffer\_for\_Distance\_Y}) = (X * \text{LinkSpeed} / 2) + 6$$

The formulas use the following parameters:

$X$  = The distance determined in step 1 (in km).

$\text{LinkSpeed}$  = The speed of the link determined in step 2.

6 = The number of buffer credits reserved for fabric services, multicast, and broadcast traffic. This number is static.

14 = The number of buffer credits reserved for QoS. This number is static.

Using 50 km as the desired distance of the switch-to-switch connection and 2 Gbps as the speed of the long-distance connection, insert the numbers into the appropriate formula. The formula should read as follows:

$$(50 \text{ km} * 2 \text{ Gbps} / 2) + 6 = 56 \text{ buffers, which is the number of buffers reserved for distance.}$$

The following examples use different speeds, all based on a distance of 50 km. The distances and speeds are variables that can change depending on how your network is set up.

- If you have a distance of 50 km at 1 Gbps, then  $(50 \text{ km} * 1 \text{ Gbps} / 2) + 6 = 31$  buffers.
- If you have a distance of 50 km at 2 Gbps, then  $(50 \text{ km} * 2 \text{ Gbps} / 2) + 6 = 56$  buffers.
- If you have a distance of 50 km at 4 Gbps, then  $(50 \text{ km} * 4 \text{ Gbps} / 2) + 6 = 106$  buffers.
- If you have a distance of 50 km at 8 Gbps, then  $(50 \text{ km} * 8 \text{ Gbps} / 2) + 6 = 206$  buffers.
- If you have a distance of 50 km at 10 Gbps, then  $(50 \text{ km} * 10 \text{ Gbps} / 2) + 6 = 256$  buffers.
- If you have a distance of 50 km at 16 Gbps, then  $(50 \text{ km} * 16 \text{ Gbps} / 2) + 6 = 406$  buffers.
- If you have a distance of 50 km at 32 Gbps, then  $(50 \text{ km} * 32 \text{ Gbps} / 2) + 6 = 806$  buffers.

### Example

Consider the Brocade 300, which has a single 24-port port group and a total of 676 buffer credits for that port group. The formulas use the following parameters:

24 = The number of user ports in a port group retrieved from [Table 14](#) on page 135

8 = The number of reserved credits for each user port

676 = The number of buffer credits available in the port group

The maximum remaining number of buffer credits for the port group, after each port reserves its 8 buffer credits, is obtained from the following formula:

$$676 - (24 * 8) = 484 \text{ unreserved buffer credits}$$

492 buffers to a single port (484 + 8 [8 for the reserved buffers already allocated to that user port]), you can calculate the maximum single-port extended distance supported:

$$\text{Maximum\_Distance\_X (in km)} = (\text{BufferCredits} + 6) * 2 / \text{LinkSpeed}$$

$$498 \text{ km} = (492 + 6 \text{ buffers for Fabric Services}) * 2 / 2 \text{ Gbps}$$

If you have a distance of 50 km at 8 Gbps, then  $484 / (206 - 8) = 2$  ports.

The following values are used in the example:

- 484 -- The total number of unreserved buffer credits
- 206 -- Buffer credits needed for 50 km at 8 Gbps
- 8 -- The number of reserved buffer credits already allocated to that port

The resulting number is rounded down to the next whole number because fractions of a port are not allowed.

If you have a distance of 50 km at 1 Gbps, then  $484 / (31 - 8) = 21$  ports.

## Allocating buffer credits based on average-size frames

In cases where the frame size is average, for example 1,024 bytes, you must allocate twice the buffer credits or configure twice the distance in the long-distance LS configuration mode. Refer to [Fibre Channel gigabit values reference definition](#) on page 128 for an approximation of the calculated number of buffer credits.

1. Use the following formula to calculate the value for the *desired\_distance* parameter needed for Fabric OS to determine the number of buffer credits to allocate:

$$\text{desired\_distance} = \text{roundup} [(\text{real\_estimated\_distance} * 2112) / \text{average\_payload\_size}]$$

The *average\_payload\_size* in this equation uses 1024 bytes

If the real estimated distance is 100 km, the *desired\_distance* is 207.

$$\text{desired\_distance} = \text{roundup} [(100 * 2112) / 1024] = 207$$

When configuring the LS mode with the **portCfgLongDistance** command, enter a *desired\_distance* value of 207 for an actual 100-km link connected to an 8-Gbps E\_Port. This causes Fabric OS to allocate the correct number of buffer credits.

2. Determine the speed you will use for the long-distance connection. This example uses 8 Gbps.
3. Look up the *data\_rate* value for the speed of the connection. Refer to [Fibre Channel gigabit values reference definition](#) on page 128 to determine the *data\_rate* value.

For example, the *data\_rate* is 8.5 for a speed of 8 Gbps.

4. Use the following formula to calculate the number of buffer credits to allocate:

$$\text{buffer\_credits} = [\text{desired\_distance} * (\text{data\_rate} / 2.125)]$$

With the values for *desired\_distance* and *data\_rate* from step 1 and step 3, the value for buffer credits is calculated as follows:

$$\text{buffer\_credits} = [207 * (8.5 / 2.125)] = 828$$

### NOTE

This *buffer credits* formula does not work with LD mode because LD mode checks the distance and limits the estimated distance to the real value of 100 km. LS mode allows for the necessary *desired\_distance* value based on the data size entered, regardless of the distance.

If buffer credit recovery is enabled, Fabric OS supports a *BB\_SC\_N* range of 1 to 15; therefore, it is impossible for the *desired\_distance* value to be more than the number of buffer credits available in the pool as determined by the previous calculations. The distance for buffer credit recovery is well within the range of all possible connections. An estimated distance of 32,768 is considerably higher than the available buffer credits and only lower values of *desired\_distance* are permitted by Fabric OS.

## Configuring buffers for a single port directly

To configure the number of buffers directly, use the **-buffers** option of the **portCfgLongDistance** command. Fabric OS uses this value to calculate the total number of buffers according to the following formula:

$$\text{Total Buffers} = \text{Configured Buffers} + \text{QOS\_VC\_Credits} + \text{Non-data\_VC\_Credits}$$

Seven Virtual Channels (VCs) are required for each QoS port. Each VC requires two buffers. Thus, the total number of QoS buffers required for a port is 14 (7\*2). An additional 6 VCs are required for nondata transmission (for example, control traffic). As a consequence, for a QoS port, 20 buffers are added. For a non-QoS port, 6 buffers are added.

For example, if the configured number of buffers is 100, then the total number of buffers allocated for a QoS port is 120, as shown in the following example.

$$\text{Total\_Buffers} = 100 + 14 + 6 = 120$$

If the configured number of buffers is 100, the total number of buffers allocated for a non-QoS port is 106, as shown in the following example.

$$\text{Total\_Buffers} = 100 + 6 = 106$$

### NOTE

You cannot use the **-buffers** option with the **-distance** option or the **-frameSize** option.

```
switch:admin> portcfglongdistance 2/35 LS 1 -buffers 400
Reserved Buffers =          420
```

## Configuring buffers using frame size

You can configure the number of buffers by using the **-frameSize** option of the **portCfgLongDistance** command along with the **-distance** option. Fabric OS calculates the number of buffers from the **-frameSize** option value according to the following formula:

$$\text{buffers\_required} = (2048 / \text{framesize}) * \text{data\_vc\_credits}$$

If you enter the average frame size of 1024, Fabric OS will allocate almost twice as many buffers as for the maximum frame size of 2048.

The **-frameSize** option value is persistent across reboots and HA failover.

### Example

```
switch:admin> portcfglongdistance 2/35 LS 1 -distance 100 -framesize 1024
```

## Calculating the number of buffers required given the distance, speed, and frame size

If you know the distance, speed, and frame size for a given port, you can use the **portBufferCalc** command to calculate the number of buffers required. If you omit the distance, speed, or frame size, the command uses the currently configured values for the port. Given the buffer requirement and port speed, you can use the same distance and frame size values when using the **portCfgLongDistance** command.

To determine the number of buffers required, complete the following steps:



1. Connect to the switch and log in using an account assigned to the admin role.
2. Enter the **portBufferCalc** command and provide values for the distance, port speed, and frame size.

The following example calculates the number of buffers required for an 8-Gbps port on a 100-km link with an average frame size of 512 bytes.

```
switch:admin> portbuffercalc 9/4 -distance 100 -speed 8 -framesize 512
1606 buffers required for 100km at 8G and framesize of 512 bytes
```

#### NOTE

The **portBufferCalc** and **portCfgEportCredits** are applicable to the 2 km ICL QSFP ports as well.

The following examples show calculation of buffers for 2 km ICL ports at 16 Gbps and 32 Gbps:

```
switch_6510:admin> portbuffercalc 1 -distance 2 -speed 16 -framesize 2048
22 buffers required for 2km at 16G and framesize of 2048bytes
```

```
switch_6510:admin> portbuffercalc 1 -distance 2 -speed 16 -framesize 1024
38 buffers required for 2km at 16G and framesize of 1024bytes
```

```
switch_6510:admin> portbuffercalc 1 -distance 2 -speed 16 -framesize 512
70 buffers required for 2km at 16G and framesize of 512bytes
```

```
switch_6510:admin> portbuffercalc 1 -distance 1 -speed 16 -framesize 2048
14 buffers required for 1km at 16G and framesize of 2048bytes
```

```
switch_6510:admin> portbuffercalc 1 -distance 1 -speed 16 -framesize 1024
22 buffers required for 1km at 16G and framesize of 1024bytes
```

```
switch_6510:admin> portbuffercalc 1 -distance 1 -speed 16 -framesize 512
38 buffers required for 1km at 16G and framesize of 512bytes
```

```
switch_G620:admin> portbuffercalc 1 -distance 2 -speed 32 -framesize 2048
38 buffers required for 2km at 32G and framesize of 2048bytes
```

```
switch_G620:admin> portbuffercalc 1 -distance 2 -speed 32 -framesize 1024
70 buffers required for 2km at 32G and framesize of 1024bytes
```

```
switch_G620:admin> portbuffercalc 1 -distance 2 -speed 32 -framesize 512
134 buffers required for 2km at 32G and framesize of 512bytes
```

```
switch_G620:admin> portbuffercalc 1 -distance 1 -speed 32 -framesize 2048
22 buffers required for 1km at 32G and framesize of 2048bytes
```

```
switch_G620:admin> portbuffercalc 1 -distance 1 -speed 32 -framesize 1024
38 buffers required for 1km at 32G and framesize of 1024bytes
```

```
switch_G620:admin> portbuffercalc 1 -distance 1 -speed 32 -framesize 512
70 buffers required for 1km at 32G and framesize of 512bytes
```

## Allocating buffer credits for F\_Ports

The default configured F\_Port buffer credit is fixed at eight buffers. You can use the **portCfgFPortBuffers** command to configure a given port with the specified number of buffers.

1. Connect to the switch and log in using an account assigned to the admin role.
2. Enter the **portCfgFPortBuffers** command.

```
switch:admin> portcfgfportbuffers --enable 2/44 12
```

Note that in the sample commands provided in the following procedure, 12 buffers are configured for an F\_Port.

To disable the port buffer configuration and return to the default buffer allocation, use the **--disable** option.

```
switch:admin> portcfgfportbuffers --disable 2/44
```

**NOTE**

The configured number of buffers for a given port is stored in the configuration database and is persistent across reboots. The F\_Port buffer feature does not support EX\_Port, Long-Distance, L\_Port, FastWrite, QoS, and Trunk Area enabled ports. F\_Port Buffers are mutually exclusive to E\_Port Credits

## Monitoring buffers in a port group

Use the **portBufferShow** command to monitor the remaining buffers on a long-distance link and to monitor the average frame size and average buffer usage for a given port.

1. Connect to the switch and log in using an account assigned to the admin role.
2. Enter the **portBufferShow** command.

The average frame size in bytes is shown in parentheses with the average buffer usage for packet transmission and reception.

```
switch:admin> portbuffershow
```

User Port	Port Type	Lx Mode	Max/Resv Buffers	Avg Buffer Usage & FrameSize		Buffer Usage	Needed Buffers	Link Distance	Remaining Buffers
				Tx	Rx				
0		-	34	- ( - )	- ( - )	0	-	-	-
1	F	-	20	- ( - )	- ( - )	8	-	-	-
2	E	-	20	- ( - )	- ( - )	26	26	<2km	-
3	E	-	20	- ( - )	- ( - )	34	34	<2km	-
4	F	-	48	- ( - )	- ( - )	48	-	-	-
5	F	-	48	- ( - )	- ( - )	48	-	-	-
6	F	-	48	- ( - )	- ( - )	48	-	-	-
7	F	-	48	- ( - )	- ( - )	48	-	-	-
8	E	LS	1634	- ( - )	- ( - )	1634	1634	100km	-
9		-	20	- ( - )	- ( - )	0	-	-	-
10	E	-	34	- ( - )	- ( - )	8	8	<2km	-
11		-	20	- ( - )	- ( - )	0	-	-	-
12		-	20	- ( - )	- ( - )	0	-	-	-
13		-	20	- ( - )	- ( - )	0	-	-	-
14		-	20	- ( - )	- ( - )	0	-	-	-
15		-	20	- ( - )	- ( - )	0	-	-	-
16		-	20	- ( - )	- ( - )	0	-	-	-
17		-	20	- ( - )	- ( - )	0	-	-	-
18		-	20	- ( - )	- ( - )	0	-	-	-
19		-	20	- ( - )	- ( - )	0	-	-	-
20		-	20	- ( - )	- ( - )	0	-	-	-
21		-	20	- ( - )	- ( - )	0	-	-	-
22		-	20	- ( - )	- ( - )	0	-	-	-
23		-	20	- ( - )	- ( - )	0	-	-	-
24		-	20	- ( - )	- ( - )	0	-	-	-
25		-	20	- ( - )	- ( - )	0	-	-	-
26		-	20	- ( - )	- ( - )	0	-	-	-
27		-	20	- ( - )	- ( - )	0	-	-	-
28		-	20	- ( - )	- ( - )	0	-	-	-
29		-	20	- ( - )	- ( - )	0	-	-	-
32		-	20	- ( - )	- ( - )	0	-	-	-
33		-	20	- ( - )	- ( - )	0	-	-	-
34		-	20	- ( - )	- ( - )	0	-	-	-
35		-	20	- ( - )	- ( - )	0	-	-	-
36		-	20	- ( - )	- ( - )	0	-	-	-
37		-	20	- ( - )	- ( - )	0	-	-	-
38		-	20	- ( - )	- ( - )	0	-	-	-
39		-	20	- ( - )	- ( - )	0	-	-	-
40		-	20	- ( - )	- ( - )	0	-	-	-
41		-	20	- ( - )	- ( - )	0	-	-	-
42		-	20	- ( - )	- ( - )	0	-	-	-
43		-	20	- ( - )	- ( - )	0	-	-	-
44		-	20	- ( - )	- ( - )	0	-	-	-
45		-	20	- ( - )	- ( - )	0	-	-	-
46		-	20	- ( - )	- ( - )	0	-	-	-
47	E	-	20	- ( - )	- ( - )	26	26	<2km	-
48		-	20	- ( - )	- ( - )	0	-	-	-

49	-	20	- ( - )	- ( - )	0	-	-
50	-	20	- ( - )	- ( - )	0	-	-
51	-	20	- ( - )	- ( - )	0	-	-
52	-	20	- ( - )	- ( - )	0	-	-
53	-	20	- ( - )	- ( - )	0	-	-
54	-	20	- ( - )	- ( - )	0	-	-
55	-	20	- ( - )	- ( - )	0	-	-
56	E	20	- ( - )	- ( - )	70	70	<2km
57	E	20	- ( - )	- ( - )	70	70	<2km
58	E	20	- ( - )	- ( - )	70	70	<2km
59	E	20	- ( - )	- ( - )	70	70	<2km
60	E	20	- ( - )	- ( - )	70	70	<2km
61	E	20	- ( - )	- ( - )	70	70	<2km
62	E	20	- ( - )	- ( - )	105	105	<2km
63	E	20	- ( - )	- ( - )	105	105	<2km 11522

## Buffer credits per switch or blade model

The following table shows the total FC ports in a switch or blade, the number of user ports in a port group, and the unreserved buffer credits available per port group.

### Formula for Gen-6 32-Gbps devices

Remaining buffers = Total Buffers - [(Total FE Ports \* 20) + (Total BE/BI Ports \* Buffers for BE/BI Port) + Internal buffer usages (approximately 152)].

**TABLE 14** Total FC ports, ports per port group, and unreserved buffer credits per port group

Switch/blade model	Total FC ports (per switch/blade)	User port group size	Unreserved buffer credits per port group (with minimum buffer allocation)	Unreserved buffer credits per port group (with QoS)	Unreserved buffer credits per port group (without QoS)
G620	64	64	13928	8488	10728
FC32-48	48	24	8152	6112	6952
SX6	16	16	5432	4072	4632

### Formula for Gen-5 16-Gbps and older devices

Remaining buffers = Total Buffers - [(Total FE Ports \* 8) + (Total BE/BI Ports \* Buffers for BE/BI Port) + EMB Buffers + SAB Buffers].

**TABLE 15** Total FC ports, ports per port group, and unreserved buffer credits per port group

Switch/blade model	Total FC ports per switch/blade	User port group size	Unreserved buffer credits per port group (with minimum buffer allocation)	Unreserved buffer credits per port group (with QoS)	Unreserved buffer credits per port group (without QoS)
6505	24	24	7904	7280	7424
M6505	24	24	7904	7280	7424
6510	48	48	7712	6464	6752
6520	96	24	4784	4160	4304
6542	48	48	7712	6464	6752
6543	24	24	7904	7280	7424
6545	26	26	7888	7212	7368
6546	24	24	7904	7280	7424
6547	48	48	7712	6464	6752
6548	28	28	7872	7144	7312
6549	28	28	7904	7280	7424

**TABLE 15** Total FC ports, ports per port group, and unreserved buffer credits per port group (continued)

Switch/blade model	Total FC ports per switch/blade	User port group size	Unreserved buffer credits per port group (with minimum buffer allocation)	Unreserved buffer credits per port group (with QoS)	Unreserved buffer credits per port group (without QoS)
6558	48	48	7712	6464	6752
6559	48	48	7712	6464	6752
7840	24	24	5024	4400	4544
FC16-32	32	16	5408/2464	4992/2048	5088/2144
FC16-48	48	24	4960/2016	4336/1392	4480/1536
FC16-64	64	32	4288/1344	3456/512	3648/704
FX8-24	12	12	988	676	748

For the FC16-x port blades, the first number in the "Unreserved buffer credits per port group" column designates the number of unreserved buffers per port group without buffer optimized mode; the second number designates the unreserved buffers with buffer optimized mode enabled on the slot. Use the **bufOpMode** command to display or change the buffer optimized mode.

**TABLE 16** Minimum buffers allocated per port type

Port type	Minimum buffers allocated per port
32-Gbps Gen 6 / Condor 4 - F_Port	20
32-Gbps Gen 6 / Condor 4 - E_Port (non QoS) or F_Port trunk without QoS	70
32-Gbps Gen 6 / Condor 4 - E_Port with QoS, F_Port with AoQ, or F_Port trunk with QoS	105
16/10/8/4-Gbps Gen 6 / Condor 4 - F_Port	8
16/10/8/4-Gbps Gen 6 / Condor 4 - E_Port (non QoS), or F_Port trunk without QoS	28
16/10/8/4-Gbps Gen 6 / Condor 4 - E_Port with QoS, F_Port with AoQ, or F_Port trunk with QoS	34
16/10/8/4/2-Gbps Gen 5 / Condor 3 - F_Port	8
16/10/8/4/2-Gbps Gen 5 / Condor 3 - E_Port (non QoS), or F_Port trunk without QoS	28
16/10/8/4/2-Gbps Gen 5 / Condor 3 - E_Port with QoS, F_Port with AoQ, or F_Port trunk with QoS	34

## Maximum configurable distances for Extended Fabrics

The following table shows the maximum supported extended distances (in kilometers) that can be configured for one port on a specific switch or blade at different speeds.

### Formula for Gen-6 32-Gbps devices

The remaining buffers = (Total FE Ports \* 20) + (Total BE/BI Ports \* Buffers for BE/BI Port) + Internal buffer usages (approximately 152)

Long distance Calculation: Buffers = distance \* speed \* 0.5

Distance = (Buffers \* 2) / speed

**TABLE 17** Configurable distances for Extended Fabrics

Switch/blade model	Maximum distances (km) that can be configured (assuming a 2112-byte frame size)				
	4 Gbps	8 Gbps	10 Gbps	16 Gbps	32 Gbps
G620	6068	3034	2427	1517	758
FC32-48	4073	2036	1629	1018	509
SX6	2713	1356	1085	678	339

## Formula for Gen-5 16-Gbps and older devices

The remaining buffers = (Total FE Ports \* 8) + (Total BE/BI Ports \* Buffers for BE/BI Port) + EMB Buffers + SAB Buffers

**TABLE 18** Configurable distances for Extended Fabrics

Switch/blade model	Maximum distances (km) that can be configured (assuming a 2112-byte frame size)				
	2 Gbps	4 Gbps	8 Gbps	10 Gbps	16 Gbps
M6505	N/A	3949	1974	N/A	987
6505	7898	3949	1974	N/A	987
6510	7706	3853	1926	1541	963
6520	4778	2389	1194	955	597
6542	N/A	3853	1926	N/A	963
6543	N/A	3949	1974	N/A	987
6545	N/A	3941	1970	N/A	985
6546	N/A	3949	1974	N/A	987
6547	N/A	3853	1926	N/A	963
6548	N/A	3933	1966	N/A	983
6549	N/A	3949	1974	N/A	987
6558	N/A	3853	1926	N/A	963
6559	N/A	3853	1926	N/A	963
7840	5018	2509	1254	1003	627
FC16-32	5402/2458	2701/1229	1350/614	1080/491	675/307
FC16-48	4954/2010	2477/1005	1238/502	990/402	619/251
FC16-64	4282/1338	2141/669	1070/334	856/267	535/167
	*** Extended Fabrics is not recommended on this blade due to buffer limitations but can be configured. ***				
FX8-24	982	491	245	N/A	N/A

### NOTE

The distances in the above table assume that QoS is enabled. If QoS is disabled, the maximum supported distances are higher, because QoS requires an additional 20 buffer credits per active port.

*Estimated maximum equally distributed distance = 1-port maximum distance/Number of ports*

### NOTE

For the FC16-x port blades, the first number in the speed column designates the distance (km) supported at that speed without buffer optimized mode; the second number designates the distance (km) supported at that speed with buffer optimized mode enabled on the slot. Use the **bufOpMode** command to display or change the buffer optimized mode

For example, for three ports running at 2 Gbps on a Brocade 6505 switch, the maximum equally distributed distance is calculated as 7898 / 3 = 2633 km.

## Downgrade considerations

### NOTE

The downgrade from Fabric OS 7.3.0 to 7.2.0 or 7.1.0 is not affected by the conditions discussed in this section. These conditions are applicable only for downgrading from Fabric OS 7.1.0 to an earlier version.

When Fabric OS firmware is downgraded from version 7.1 to an earlier version, the effect depends on whether the number of buffer credits for the long-distance port is configured with the **-framesize** and **-distance** options or with the **-buffers** option.

### When a port is configured with **-framesize** and **-distance** options

In Fabric OS v7.1, if you configure the port by using the **-distance** option alone, the reserved buffers are calculated according to the distance. If you configure both the **-framesize** option and the **-distance** option, more buffers will be reserved, depending on the frame size.

With a firmware downgrade, those ports that were configured with more reserved buffers will keep the reserved buffers as long as the ports remain online. The next time the port is toggled, buffers will again be reserved on the basis of distance only.

### When a port is configured with the **-buffers** option

A firmware downgrade from Fabric OS 7.1.0 to any earlier version is blocked when a port is configured as a long-distance port by means of the **-buffers** option. The following warning message is displayed:

```
Downgrade to selected version is not allowed because few ports are configured with longdistance -buffers option. Please remove the configuration using portcfglongdistance <slot>/<port> L0 CLI or change the configuration with -distance option on the console.
```

#### NOTE

The downgrade from Fabric OS 7.3.0 to 7.2.0 or 7.1.0 is not blocked due to this reason.

## Configuring credits for a single VC

You can alter the default credit allocation for a normal distance E\_Port or EX\_Port so that a specific number of credits is allocated to a port. When you allocate a specific number of credits to an E\_Port or EX\_Port, the number of credits specified override the default credit allocation. When this feature is disabled, the default credit model is restored. Only a normal distance E\_Port and EX\_Port can utilize the new credit model, and the allocated credits are reserved only for that port.

When this feature is enabled, the E\_Port credit configuration is persistent across system reboots and High Availability (HA) failover.

This feature is supported on E\_Ports and EX\_Ports. It does not support ports configured as F\_Ports, Mirror Ports, L\_Ports, and Longdistance Ports. If E\_Port credits are configured on ports, you cannot move the ports from one logical switch to another. You can also allocate buffers for 2 km ICL ports.

### Increasing credits for normal distance E\_Ports

Use the following steps to allocate credits to an E\_Port.

1. Connect to the switch and log in using an account assigned to the admin role.
2. Enter the **portCfgEPortCredits --enable** command to allocate credits to an E\_Port. In the following example, 14 credits are allocated to each of the medium Virtual Channels (VCs) for non-QoS ports, and to both the medium and high VCs for QoS ports.

```
switch:admin> portcfgeportcredits --enable 12/6 14
Success
```

3. Enter the **portCfgEPortCredits --show** command to verify that the credits have been allocated to the E\_Port. In the following example, it is verified that 14 credits per VC have been allocated to the E\_Port.

```
switch:admin> portcfgeportcredits --show 12/6
E-Port Credit Configured : 14
Success.
```

## Buffer credit recovery

Buffer credit recovery allows links to recover after buffer credits are lost when the buffer credit recovery logic is enabled. The buffer credit recovery feature also maintains performance. If a credit is lost, a recovery attempt is initiated. During link reset, the frame and credit loss counters are reset without performance degradation.

Credit recovery is supported on E\_Ports, F\_Ports, and EX\_Ports. Buffer credit recovery is enabled automatically across any long-distance connection for which the E\_Port, F\_Port, or EX\_Port buffer credit recovery mechanism is supported.

For 16-Gbps and 32-Gbps FC devices and blades (Brocade 6505, 6510, 6520, G620, M6505, 6547, CR32-4, CR32-8, CR16-4, CR16-8, FC32-48, FC16-32, FC16-48, FC16-64):

- You can use the **portCfgCreditRecovery** command to disable or enable buffer credit recovery on a port.

### NOTE

The credit recovery mode is supported when a link is in ISL\_RDY mode and VC Init is off (only on VCO). If VC init is off, and ISL\_RDY mode is set, then VCO will support credit recovery.

## Buffer credit recovery over an E\_Port

To support buffer credit recovery, E\_Ports must be connected between devices that support 32 or 16 Gbps, or between devices that support 8 Gbps.

- Devices that support 32 Gbps
  - Brocade G620
  - FC32-48, SX6

If a device that supports 32 Gbps is connected to a device that supports only 16 Gbps, buffer credit recovery is disabled, even if both devices are running 16 Gbps.

- Devices that support 16 Gbps:
  - Brocade 6505, 6510, 6520, M6505, 6543, 6547
  - FC16-32, FC16-48, FC16-64

If a device that supports 16 Gbps is connected to a device that supports only 8 Gbps, buffer credit recovery is disabled, even if both devices are running 8 Gbps.

There is a limited amount of credit recovery that occurs between 32/16G platforms and 8G platforms.

The buffer credit recovery feature for E\_Ports is enabled for the following flow-control modes:

- Normal (R\_RDY)
- Virtual Channel (VC\_RDY)
- Extended VC (EXT\_VC\_RDY)

## Buffer credit recovery over an F\_Port

Buffer credit recovery for F\_Ports is supported for F\_Port-to-N\_Port links between a Brocade switch and Access Gateway, between a Brocade switch and an adapter, and between an Access Gateway and an adapter. For an F\_Port on a Brocade switch connected to an Access Gateway, the following conditions must be met:

- Both devices must run Fabric OS v7.1 or later.
- Fabric OS must support buffer credit recovery at either end of the link.
- If both devices support 16 Gbps, the flow-control mode can be either Normal mode (R\_RDY) or VC mode (VC\_RDY); otherwise the flow-control mode must be R\_RDY.

For an F\_Port on a Brocade switch or Access Gateway connected to an adapter, the following conditions must be met:

- The Brocade switch or Access Gateway must run Fabric OS v7.1 or later.
- Fabric OS must support buffer credit recovery at both ends of the link.
- The adapter must be running HBA v3.2 firmware or later.
- The adapter must operate at maximum speed.
- The flow-control mode must be R\_RDY.

The feature is enabled automatically during a link reset if the conditions are met. If the conditions for buffer credit recovery are not met, the link will come up, but buffer credit recovery will not be enabled.

## Buffer credit recovery over an EX\_Port

Buffer credit recovery is supported on a Fibre Channel router (FCR) EX\_Port that connects over an inter-fabric link (IFL) to an edge fabric E\_Port when the following conditions are met:

- The FCR and the switch at the other end of the IFL must both run Fabric OS v7.1 or later.
- The FCR and the switch at either end of the IFL must both support 32, 16, or 8 Gbps. Buffer credit recovery is not supported if the EX\_Ports do not support the same data rate.
- Either end of the IFL must support buffer credit recovery.
- If the inter-fabric link (IFL) connects devices that support 8 Gbps only, long-distance mode must also be enabled. Long-distance mode can be enabled or disabled on devices that support 16 and 32 Gbps.
- Virtual Channel flow control (VC\_RDY) or Extended VC flow control (EXT\_VC\_RDY) mode must be in use. Buffer credit recovery is not supported for EX\_Ports when normal (R\_RDY) flow control mode is in use.

The feature is enabled automatically during a link reset if the conditions are met. If the capabilities at either end of the EX\_Port-to-E\_Port link are not matched, the link will come up, but refer to the *Fabric OS Command Reference* for lists of devices and blades that support 32, 16, and 8 Gbps.

## Enabling and disabling buffer credit recovery

### NOTE

By default, buffer credit recovery is not enabled on any of the platforms.

1. To disable buffer credit recovery on a port, perform the following steps.
  - a) Connect to the switch and log in using an account assigned to the admin role.
  - b) Enter the **portCfgCreditRecovery** command and include the **-disable** option.

The following example disables buffer credit recovery on port 1/20.

```
switch:admin> portcfgcreditrecovery 1/20 -disable
```

2. To enable buffer credit recovery on a port for which it has been disabled, perform the following steps.
  - a) Connect to the switch and log in using an account assigned to the admin role.
  - b) Enter the **portCfgCreditRecovery** command and include the **enable** option.

The following example enables buffer credit recovery on port 1/20.

```
switch:admin > portcfgcreditrecovery 1/20 -enable
```



## Credit loss detection

Fabric OS 7.1.0 and later supports credit loss detection for back-end ports and core blades, and on the Brocade 5300 and 6520 switches, although the support is slightly different on each device. Refer to the following topics for information on credit loss detection for these devices; and the *Fabric OS Troubleshooting and Diagnostics Guide* for more general information on credit loss detection.

## Back-end credit loss detection and recovery support on Brocade 6520 switches

The following credit loss detection methods are supported for Brocade 6520 back-end ports:

- Per-port polling to detect credit loss. If credit loss is detected using this method, the RASlog C3-1012 message is displayed and recorded.
- Per-VC credit loss detection. If single-credit loss is detected using this method, it will be automatically recovered and the RASlog C3-1023 message is displayed and recorded. If multi-credit loss is detected using this method, the RASlog C3-1013 message is displayed and recorded. There is no automatic recovery for multi-credit loss.
- Complete VC credit loss detection. If credit loss is detected using this method, the RASlog C3-1011 message is displayed and recorded.

The following credit loss recovery methods are supported for Brocade 6520 back-end ports:

- For all the credit loss methods described previously, a link reset will automatically be performed, assuming that this option was enabled. Refer to [Enabling back-end credit loss detection and recovery for link reset thresholds](#) on page 141 for details on enabling this feature.
- A manual link reset option using the **creditRecovMode** command is also available. Refer to [Enabling back-end credit loss detection and recovery for link reset thresholds](#) on page 141 for instructions.

### NOTE

Whenever a link reset is performed on this switch, the RASlog C3-1014 message is displayed and recorded.

## Enabling back-end credit loss detection and recovery for link reset thresholds

Credit loss detection and recovery is enabled and disabled using the **creditrecovmode** command, which is only supported on the back-end ports of Brocade 6520, Brocade G620, and 16 and 32 Gbps-capable Fiber Channel blades in Brocade DCX 8510 Backbones, and X6 Directors chassis.

### ATTENTION

This command may be constrained by Virtual Fabric restrictions. Refer to the *Fabric OS Troubleshooting and Diagnostics Guide* for more information.

In versions of Fabric OS prior to 7.4.0, the fault option in **creditrecovmode** applied only if a link reset threshold is set. In Fabric OS 7.4.0 and later, **creditrecovmode --fault** makes this fault option applicable to all back-end link failures. Which blade fault is registered due to a back-end link failure will be decided by the blade fault option. If credit recovery mode is off and there are any back-end link failures, then Fabric OS will fault the core blade; if there is only one core blade, then Fabric OS will fault the edge blade. Refer to [Back-end credit loss detection and recovery for link faults](#) on page 143 for additional information on using **creditrecovmode --fault**.

To enable back-end credit loss detection and recovery, perform the following steps.

For more information on **creditrecovmode** command options, refer to the *Fabric OS Command Reference*.

1. Connect to the switch and log in using an account assigned to the admin role.
2. Enter **creditrecovmode --cfg** to enable credit recovery of back-end ports.

In the following example, back-end port credit loss recovery is enabled with the link reset only option.

```
switch:admin> creditrecovmode --cfg onLrOnly
```

3. Enter **creditrecovmode --show** to display information about the back-end port credit recovery configuration. In the following example, back-end port credit loss recovery is enabled with the "link reset only" option.

```
switch:admin> creditrecovmode --show
Internal port credit recovery is Enabled with LrOnly
C2 FE Complete Credit Loss Detection is Enabled
```

## Performing link reset for loss of sync from peer ports

You can perform link reset on all the 8-Gbps, 16-Gbps, and 32-Gbps ports backend ports if there is a loss of sync from peer ports. You can configure either or both of the following link resets.

1. Run the **creditrecovmode --be\_crdloss [off|on]** to configure the credit loss detection link reset. By default, it is off.
2. Run the **creditrecovmode --be\_losync [off|on]** to configure the loss of sync detection link reset. By default, it is off.

The link reset action is decided based on the **--lrthreshold**, **--crdLoss**, and **--losync** settings as per the following matrix.

Lrthreshold	crdloss	losync	Link reset action
On	Off	On	Link resets with threshold logic to fault blade.
Off	Off	On	Link resets with no threshold logic.
On	On	Off	Link resets with threshold logic to fault blade.
Off	On	Off	Link resets with no threshold logic.
On	On	On	Link resets with threshold logic to fault blade.
Off	On	On	Link resets with no threshold logic.
Off/On	Off	Off	No link reset.

For example, to activate both credit loss and loss of sync with link reset and NO threshold, use the following command:

```
switch:admin> creditrecovmode --cfg onLrOnly
```

For example, to activate both credit loss and loss of sync with link reset and threshold (10), use the following command:

```
switch:admin> creditrecovmode --cfg onLrThresh --lrthreshold 2
switch:admin> creditrecovmode -show
Internal port credit recovery is Enabled with LrThresh
Back end port Loss of Sync's Link Reset is Enabled with LrThresh
LR threshold (currently activated): 2
Fault Option : COREBLADE
C2 FE Complete Credit Loss Detection is Disabled
```

For example, to enable link reset for credit loss alone, use the following command.

```
switch:admin> creditrecovmode --be_crdloss on
switch:admin> creditrecovmode --show
Internal port credit recovery is Enabled with LrThresh
Back end port Loss of Sync's Link Reset is Disabled
LR threshold (currently activated): 2
Fault Option : COREBLADE
C2 FE Complete Credit Loss Detection is Disabled
```

For example, to disable link reset for credit loss alone, use the following command.

```
switch:admin> creditrecovmode --be_crdloss off
switch:admin> creditrecovmode --show
Internal port credit recovery is Disabled
Back end port Loss of Sync's Link Reset is Enabled with LrThresh
LR threshold (currently activated): 2
Fault Option : COREBLADE
C2 FE Complete Credit Loss Detection is Disabled
```

For example, to enable link reset for loss of sync alone, use the following command.

```
switch:admin> creditrecovmode --be_losync on
switch:admin> creditrecovmode --show
Internal port credit recovery is Enabled with LrThresh
Back end port Loss of Sync's Link Reset is Enabled with LrThresh
LR threshold (currently activated): 2
Fault Option : COREBLADE
C2 FE Complete Credit Loss Detection is Disabled
```

For example, to disable link reset for loss of sync alone, use the following command.

```
switch:admin> creditrecovmode --be_losync off
switch:admin> creditrecovmode --show
Internal port credit recovery is Disabled
Back end port Loss of Sync's Link Reset is Disabled
LR threshold (not currently activated): 2
Fault Option : COREBLADE
C2 FE Complete Credit Loss Detection is Disabled
```

## Back-end credit loss detection and recovery for link faults

The following table identifies the blade that is faulted based on the factors.

**TABLE 19** Blade fault scenarios

Fault Option	Back-end link failure location	Edge chip fault count	Core chip fault count	Faulted blade when director has single active core	Faulted blade when director has dual active cores
edgeblade	Edge Blade	N/A	N/A	Edge Blade	Edge Blade
edgeblade	Core Blade	N/A	N/A	Edge Blade	Edge Blade

TABLE 19 Blade fault scenarios (continued)

Fault Option	Back-end link failure location	Edge chip fault count	Core chip fault count	Faulted blade when director has single active core	Faulted blade when director has dual active cores
coreblade	Edge Blade	N/A	N/A	Edge Blade	Core Blade
coreblade	Core Blade	N/A	N/A	Edge Blade	Core Blade
edgecoreblade	Edge blade	N/A	<2	Edge blade	Edge blade
edgecoreblade	Edge blade	N/A	>2	Edge blade	Core Blade
edgecoreblade	Core blade	N/A	<2	Edge blade	Edge blade
edgecoreblade	Core blade	N/A	>2	Edge blade	Core blade

### Examples of credit recovery mode fault commands

The following examples illustrate the use of the `creditrecovmode --fault` command in various settings.

```
switch:admin> creditrecovmode --fault edgeblade
switch:admin> creditrecovmode -show
Internal port credit recovery is Disabled
Back end port Loss of Sync's Link Reset is Enabled with LrThresh
LR threshold (currently activated): 2
Fault Option : EDGEBLADE
C2 FE Complete Credit Loss Detection is Disabled
```

```
switch:admin> creditrecovmode --fault edgecoreblade
switch:admin> creditrecovmode --show
Internal port credit recovery is Disabled
Back end port Loss of Sync's Link Reset is Enabled with LrThresh
LR threshold (currently activated): 2
Fault Option : EDGECOREBLADE
C2 FE Complete Credit Loss Detection is Disabled
```

```
switch:admin> creditrecovmode --fault coreblade
switch:admin> creditrecovmode -show
Internal port credit recovery is Disabled
Back end port Loss of Sync's Link Reset is Enabled with LrThresh
LR threshold (currently activated): 2
Fault Option : COREBLADE
C2 FE Complete Credit Loss Detection is Disabled
```

# Managing User Accounts

---

• User accounts overview .....	145
• Local database user accounts.....	149
• Local user account database distribution.....	151
• Password policies.....	152
• The boot PROM password.....	157
• Remote authentication.....	160

## User accounts overview

In addition to the default permissions assigned to the roles of root, admin, and user, Fabric OS supports up to 252 additional user accounts on the chassis. These accounts expand your ability to track account access and audit administrative activities.

### NOTE

Upon new installation of Fabric OS, the root user must be enabled.

Each user account is associated with the following:

- Permissions — Associate roles with each user account to determine the functional access levels.
- Virtual Fabric list — Specifies the Virtual Fabric a user account is allowed to log in to.
- Home Virtual Fabric — Specifies the Virtual Fabric that the user is logged in to, if available. The home Virtual Fabric must be a member of the user's Virtual Fabric list. If the fabric ID is not available, the next-lower valid fabric ID is used.
- LF Permission List — Determines functional access levels within the bounds of the user's Virtual Fabrics.
- Chassis role — Similar to switch-level roles, but applies to a different subset of commands.

For more information about Virtual Fabrics, refer to [Managing Virtual Fabrics](#) on page 267.

Fabric OS provides four options for authenticating users: remote RADIUS service, remote LDAP service, remote TACACS+ service, and the local-switch user database. All options allow users to be managed centrally by means of the following methods:

- Remote RADIUS service — Users are managed in a remote RADIUS server. All switches in the fabric can be configured to authenticate against the centralized remote database.
- Remote LDAP service — Users are managed in a remote LDAP server. All switches in the fabric can be configured to authenticate against the centralized remote database. The remote LDAP server can run Microsoft Active Directory or OpenLDAP.
- Remote TACACS+ service — Users are managed in a remote TACACS+ server. All switches in the fabric can be configured to authenticate against the centralized remote database.
- Local user database — Users are managed by means of the local user database. The local user database is manually synchronized by means of the **distribute** command to push a copy of the switch's local user database to all other switches in the fabric running Fabric OS v5.3.0 and later, but the **distribute** command is blocked if users with user-defined roles exist on the sending switch or on any remote, receiving switch.

## Role-Based Access Control

Role-Based Access Control (RBAC) specifies the permissions that a user account has on the basis of the role the account has been assigned. For each role, a set of predefined permissions determines the jobs and tasks that can be performed on a fabric and its associated fabric elements. Fabric OS uses RBAC to determine which commands a user is allowed to access.

When you log in to a switch, your user account is associated with a predefined role or a user-defined role. The role that your account is associated with determines the level of access you have on that switch and in the fabric. The chassis role can also be associated with user-defined roles; it has permissions for RBAC classes of commands that are configured when user-defined roles are created. The chassis role is similar to a switch-level role, except that it affects a different subset of commands. You can use the **userConfig** command to add this permission to a user account.

The following table outlines the Fabric OS predefined (default) roles.

**TABLE 20** Default Fabric OS roles

Role name	Duties	Description
Admin	All administration	All administrative commands
BasicSwitchAdmin	Restricted switch administration	Mostly monitoring with limited switch (local) commands
FabricAdmin	Fabric and switch administration	All switch and fabric commands, excluding user management commands
Operator	General switch administration	Routine switch-maintenance commands.
SecurityAdmin	Security administration	All switch security and user management functions
SwitchAdmin	Local switch administration	Most switch (local) commands, excluding security, user management, and zoning commands
User	Monitoring only	Nonadministrative use, such as monitoring system activity
ZoneAdmin	Zone administration	Zone management commands only

## Role permissions

The following table describes the types of permissions that are assigned to roles.

**TABLE 21** Permission types

Abbreviation	Definition	Description
O	Observe	The user can run commands by using options that display information only, such as running <b>userConfig --show -a</b> to show all users on a switch.
M	Modify	The user can run commands by using options that create, change, and delete objects on the system, such as running the <b>userConfig --change</b> command with the <b>-r</b> option to change a user's role.
OM	Observe and Modify	The user can run commands by using both observe and modify options; if a role has modify permissions, it almost always has observe permissions.
N	None	The user is not allowed to run commands in a given category.

To view the permission type for categories of commands, use the **classConfig** command.

- Enter the **classConfig --show -classlist** command to list all command categories.
- Enter the **classConfig --showroles** command with the command category of interest as the argument.

This command shows the permissions that apply to all commands in a specific category.

```
switch:admin> classconfig --showroles authentication
Roles that have access to the RBAC Class 'authentication' are:
  Role name      Permission
  -----      -
  Admin          OM
  Root           OM
  Security Admin OM
```

You can also use the `classConfig --showcli` command to show the permissions that apply to a specific command.

## Management channel

The management channel is the communication established between the management workstation and the switch. The following table shows the number of simultaneous login sessions allowed for each role when authenticated locally. The roles are displayed in alphabetic order, which does not reflect their importance.

**TABLE 22** Maximum number of simultaneous sessions

Role name	Maximum sessions
Admin	4
BasicSwitchAdmin	4
FabricAdmin	4
Operator	4
SecurityAdmin	4
SwitchAdmin	4
User	4
ZoneAdmin	4

### NOTE

The total number of sessions on a switch cannot exceed 32.

## Managing user-defined roles

Fabric OS provides an extensive toolset for managing user-defined roles:

- The `roleConfig` command is available for defining new roles, deleting created roles, or viewing information about user-defined roles.
- The `classConfig` command is available for displaying RBAC information about each category or class of commands, and includes an option to show all roles associated with a given RBAC command category.
- The `userConfig` command can be used to assign a user-defined role to a user account.



### CAUTION

Brocade recommends that you do not add more than 150 user defined roles as Fabric OS and other management applications such as Brocade Network Advisor and Web Tools might encounter performance issues.

## Creating a user-defined role

You can define a role as long as it has a unique name that is not the same as any of the Fabric OS default roles, any other user-defined role, or any existing user account name.

The following conditions also apply:

- A role name is case-insensitive and contains only letters.
- The role name should have a minimum of 4 letters and can be up to 16 letters long.
- The maximum number of user-defined roles that are allowed on a chassis is 150.

The **roleConfig** command can be used to define unique roles. You must have chassis-level access and permissions to execute this command. The following example creates a user-defined role called `mysecurityrole`. The RBAC class `Security` is added to the role, and the `Observe` permission is assigned:

```
switch:admin> roleconfig --add mysecurityrole -class security -perm O
Role added successfully
```

The assigned permissions can be no higher than the admin role permission assigned to the class. The admin role permission for the `Security` class is `Observe/Modify`. Therefore, the `Observe` permission is valid.

The **roleConfig --show** command is available to view the permissions assigned to a user-defined role. You can also use the **classConfig --showroles** command to see that the role was indeed added with `Observe` permission for the `security` commands.

```
switch:admin> classConfig --showroles security
Roles that have access to RBAC Class 'security' are:
  Role Name                Permissions
  -----                -
  User                     O
  Admin                    OM
  Root                     OM
  SwitchAdmin              O
  FabricAdmin              OM
  BasicSwitchAdmin        O
  SecurityAdmin            OM
  mysecurityrole           O
```

To delete a user-defined role, use the **roleConfig --delete** command.

## Assigning a user-defined role to a user

The **userConfig** command allows you to assign a user-defined role to a user.

To assign a user-defined role to a user, complete the following steps.

1. Connect to the device and log in using an account with admin permissions.
2. You have multiple options for assigning a user-defined role to a user:
  - To create a new user account and assign a role: **userConfig --add** *user\_account* -r *role\_name*.
  - To change a user-defined role or add a new one to an existing user account: **userConfig --change** *user\_account* -r *role\_name*
  - To create a new user account and assign a chassis role: **userConfig --add** *user\_account* -c *chassis\_role\_name*.
  - To add a chassis role to an account: **userConfig --change** *user\_account* -c *chassis\_role\_name*.

The commands can be combined; the following example assigns the “`mysecurityrole`” role to the existing “`anewuser`” account and also adds the admin chassis role.

```
switch:admin> userConfig --change anewuser -r mysecurityrole -c admin
```

For more information on **userConfig** command options, refer to the *Fabric OS Command Reference*.

## Configuring time-based access

You can also restrict the access for a user to a specified time of the day. The restriction applies for Telnet, SSH, console, and Web access for a user on all days.



Run the `userConfig --add todUser` command to add time-based users.

```
switch:admin> userconfig --add toduser -r user -l 1-128 -h 128 -c user -d "Time of day User" -at
hh:mm-hh:mm
```

The first instance of hh:mm after the "-at" option indicates the start time and the second instance indicates the end time. To downgrade to a previous Fabric OS version, you need to remove the time-based user configuration.



**WARNING**

The time of access must not be configured for switch default accounts such as root or admin user as it can lock you out of the switch access completely. To provide accessibility to the switch, you must have at least one account without the time of access configured.

## Local database user accounts

User **add**, **change**, and **delete** operations are subject to the *subset* rule: an admin with LFlist 1-10 cannot perform operations on an *admin*, *user*, or any role with LFlist 11-128. The user account being changed must have an LFlist that is a subset of the account that is making the change.

In addition to the default administrative and user accounts, Fabric OS supports up to 252 user-defined accounts in each switch (domain). These accounts expand your ability to track account access and audit administrative activities.

## Default accounts

The following table lists the predefined accounts offered by Fabric OS that are available in the local-switch user database. The password for all default accounts should be changed during the initial installation and configuration of each switch.

**TABLE 23** Default local user accounts

Account name	Role	Logical Fabric	Description
admin	Admin	LF1-128 home: 128	Most commands have <i>observe/modify</i> permission
root	Root	LF1-128 home: 128	Reserved
user	User	LF-128 home: 128	Most commands have <i>observe-only</i> permission

**Virtual Fabrics considerations:** Administrators can act on other accounts only if that account has a Logical Fabric list that is a subset of the administrator.

Root user access settings:

- Root access is disabled by default and restricted to the console only. To enable the root account use the `userconfig --change root -e yes` command.
- Root access is allowed only through the console. Use the `rootAccess --set <none|consoleonly|all>` command to change the root access settings.
- The default root password must be changed in the first login.

For all users, an asterix (\*) is displayed next to the username if the password is still at default, when you run `userConfig -show` command.

**WARNING**

Do not use the `passwdDefault` command that is supported only on root because it deletes all user defined accounts and resets the passwords of root, admin, and user to the default passwords. It also deletes factory account, resets the root access back to console only, and disables the root account.

## Displaying account information

1. Connect to the switch and log in using an account with admin permissions, or an account associated with a user-defined role with permissions for the UserManagement class of commands.
2. Enter the appropriate **show** operands for the account information you want to display:
  - `userConfig --show -a` to show all account information for a switch

**NOTE**

A \* is displayed next to the user names that still have the default password set.

- `userConfig --show username` to show account information for the specified account
- `userConfig --showlf -l logicalFabric_ID` for each LF in an LF\_ID\_list, displays a list of users that include that LF in their LF permissions.

## Creating an account

1. Connect to the switch and log in using an account with admin permissions, or an account associated with a user-defined role with permissions for the UserManagement class of commands.
2. Enter the `userConfig --add` command.

```
> userconfig --add metoo -l 1-128 -h 128 -r admin -c admin
```

This example creates a user account for the user metoo with the following properties:

- Access to Virtual Fabrics 1 through 128
  - Default home logical switch to 128
  - Admin role permissions
  - Admin chassis role permissions
3. In response to the prompt, enter a password for the account.

The password is not displayed when you enter it on the command line.

## Deleting an account

This procedure can be performed on local user accounts.

1. Connect to the switch and log in using an account with admin permissions, or an account associated with a user-defined role with permissions for the UserManagement class of commands.
2. Enter the `userConfig --delete` command.

You cannot delete the default accounts. An account cannot delete itself. All active CLI sessions for the deleted account are logged out.

3. At the prompt for confirmation, enter **y**.

## Changing account parameters

This procedure can be performed on local user accounts.

1. Connect to the switch and log in using an account with admin permissions, or an account associated with a user-defined role with permissions for the UserManagement class of commands.
2. Enter the **userConfig --change** command.

## Local account passwords

The following rules apply to changing passwords:

- Users can change their own passwords.
- To change the password for another account requires admin permissions or an account associated with a user-defined role with Modify permissions for the LocalUserEnvironment RBAC class of commands. When changing an admin account password, you must provide the current password.
- An admin with ADlist 0-10 or LFlist 1-10 cannot change the password on an account with admin, user, or any permission with an ADlist 11-25 or LFlist 11-128. The user account being changed must have an ADlist that is a subset of the account that is making the change.
- A new password must have at least one character different from the previous password.
- You cannot change passwords by using SNMP.

## Changing the password for the current login account

1. Connect to the switch and log in using an account with admin permissions.
2. Enter the **passwd** command.
3. Enter the requested information at the prompts.

## Changing the password for a different account

1. Connect to the switch and log in using an account with admin permissions.
2. Enter the **passwd** command specifying the name of the account for which the password is being changed.
3. Enter the requested information at the prompts.

## Local user account database distribution

Fabric OS allows you to distribute the user database and passwords to other switches in the fabric. When the switch accepts a distributed user database, it replaces the local user database with the user database it receives.

By default, switches accept the user databases and passwords distributed from other switches. The "Locked" status of a user account is not distributed as part of local user database distribution.

When the user database is distributed, it may be rejected by a switch for one of the following reasons:

- One of the target switches does not support local account database distribution.
- One of the target switch's user databases is protected.
- One of the remote switches has logical switches defined.
- Either the local switch or one of the remote switches has user accounts associated with user-defined roles.

## Distributing the local user database

When the local user database is distributed, all user-defined accounts residing in the receiving switches are logged out of any active sessions.

1. Connect to the switch and log in using an account with admin permissions.
2. Enter the **distribute -p PWD -d** command.

**NOTE**

If Virtual Fabrics mode is enabled and there are logical switches defined other than the default logical switch, then distributing the password database to switches is not supported. Distributing the password database to switches is not allowed if there are users associated with user-defined roles in either the sending switch or the remote switch

**NOTE**

The passwords are distributed only to switches running Fabric OS 8.0.1 if the receiving switch password has is MD5. Otherwise, the password has enforcement is applied and the passwords have to be changed before login.

## Accepting distributed user databases on the local switch

1. Connect to the switch and log in using an account with admin permissions.
2. Enter the **fddCfg --localaccept PWD** command.

## Rejecting distributed user databases on the local switch

1. Connect to the switch and log in using an account with admin permissions.
2. Enter the **fddCfg --localreject PWD** command.

## Password policies

The password policies described in this section apply to the local-switch user database only. Configured password policies (and all user account attribute and password state information) are synchronized across CPs and remain unchanged after an HA failover. Password policies can also be manually distributed across the fabric (refer to [Local user account database distribution](#) on page 151).

## Password strength policy

The password strength policy is enforced across all user accounts, and enforces a set of format rules to which new passwords must adhere. The password strength policy is enforced only when a new password is defined. The total of the other password strength policy parameters (lowercase, uppercase, digits, and punctuation) must be less than or equal to the value of the MinLength parameter.

Use the following attributes to the **passwdCfg** command to set the password strength policy:

- Lowercase  
Specifies the minimum number of lowercase alphabetic characters that must appear in the password. The default value is zero. The maximum value must be less than or equal to the MinLength value.
- Uppercase  
Specifies the minimum number of uppercase alphabetic characters that must appear in the password. The default value is zero. The maximum value must be less than or equal to the MinLength value.
- Digits  
Specifies the minimum number of numeric digits that must appear in the password. The default value is zero. The maximum value must be less than or equal to the MinLength value.
- Punctuation

Specifies the minimum number of punctuation characters that must appear in the password. All printable, non-alphanumeric punctuation characters except the colon ( : ) are allowed. The default value is zero. The maximum value must be less than or equal to the MinLength value.

- MinLength

Specifies the minimum length of the password. The minimum can be from 8 through 40 characters. New passwords must be between the minimum length specified and 40 characters. The default value is 8. The maximum value must be greater than or equal to the MinLength value.

- CharSet

Specifies the minimum length of the character set. Character set includes alphabets and special characters. The default value is 0. For example, if the **-charset** option is set to 3, then the password should contain at least 3 characters (can be 2 alphabets and 1 special character, or 3 alphabets or any other combination). However, there can be more than three characters and include digits as part of the password. But the password cannot have less than three characters.

- AllowUser

Specifies whether to allow username to be included in the password either in the forward or reverse order of characters. The default value is set to "yes" for "-allowusername" option. If the option is set to "no", the username both in forward and reverse direction is not allowed to be part of the password.

- Repeat

Specifies the length of repeated character sequences that will be disallowed. For example, if the "repeat" value is set to 3, a password "passAAword" is disallowed because it contains the repeated sequence "AAA". A password of "passAAword" would be allowed because no repeated character sequence exceeds two characters. The range of allowed values is from 1 through 40. The default value is 1.

- Sequence

Specifies the length of sequential character sequences that will be disallowed. A sequential character sequence is defined as a character sequence in which the ASCII value of each contiguous character differs by one. The ASCII value for the characters in the sequence must all be increasing or decreasing. For example, if the "sequence" value is set to 3, a password "passABCword" is disallowed because it contains the sequence "ABC". A password of "passABword" would be allowed because it contains no sequential character sequence exceeding two characters. The range of allowed values is from 1 through 40. The default value is 1. When set to 1, sequential characters are not enforced.

- Reverse

Activates or deactivates the validation check to determine whether the password is an exact reverse string of the user name. This option is disabled by default.

#### Example of a password strength policy

The following example shows a password strength policy that requires passwords to contain at least 3 uppercase characters, 4 lowercase characters, and 2 numeric digits; the minimum length of the password is 9 characters. The password cannot be an exact reverse string of the username.

```
switch:admin> passwdcfg --set -uppercase 3 -lowercase 4 -digits 2 -minlength 9 -reverse 1
```

## Password history policy

The password history policy prevents users from recycling recently used passwords, and is enforced across all user accounts when users are setting their own passwords. The password history policy is enforced only when a new password is defined.

Specify the number of past password values that are disallowed when setting a new password. Allowable password history values range from 0 through 24. If the value is set to 0, the new password cannot be set to the current password, but can be set to the most recent

password. The default value is 1, which means the current and one previous password cannot be reused. The value 2 indicates that the current and the two previous passwords cannot be used (and so on, up to 24 passwords).

This policy does not verify that a new password meets a minimal standard of difference from prior passwords; rather, it only determines whether or not a newly specified password is identical to one of the specified number (1-24) of previously used passwords.

The password history policy is not enforced when an administrator sets a password for another user; instead, the user's password history is preserved and the password set by the administrator is recorded in the user's password history.

#### NOTE

You can also use the `-oldpasswd` option to enable or disable old password check while changing the root password.

## Password expiration policy

The password expiration policy forces the expiration of a password after a configurable period of time. The expiration policy can be enforced across all user accounts or on specified users only. A warning that password expiration is approaching is displayed when the user logs in. When a password expires, the user must change the password to complete the authentication process and open a user session. You can specify the number of days prior to password expiration during which warnings will commence. Password expiration does not disable or lock out the account.

Use the following attributes to the `passwdCfg` command to set the password expiration policy:

- **MinPasswordAge**  
Specifies the minimum number of days that must elapse before a user can change a password. `MinPasswordAge` values range from 0 through 999. The default value is zero. Setting this parameter to a nonzero value discourages users from rapidly changing a password in order to circumvent the password history setting to select a recently used password. The `MinPasswordAge` policy is not enforced when an administrator changes the password for another user.
- **MaxPasswordAge**  
Specifies the maximum number of days that can elapse before a password must be changed, and is also known as the password expiration period. `MaxPasswordAge` values range from 0 through 999. The default value is zero. Setting this parameter to zero disables password expiration.
- **Warning**  
Specifies the number of days prior to password expiration that a warning about password expiration is displayed. `Warning` values range from 0 through 999. The default value is 0 days.

#### NOTE

When `MaxPasswordAge` is set to a nonzero value, `MinPasswordAge` and `Warning` must be set to a value that is less than or equal to `MaxPasswordAge`.

#### Example of password expiration policies

The following example configures a password expiration policy for the `metoo` user account. This user must change the password within 90 days of setting the current password and no sooner than 10 days after setting the current password. The user will start to receive warning messages 3 days before the 90-day limit, if the password is not already changed.

```
switch:admin> passwdcfg --setuser metoo -minpasswordage 10 -maxpasswordage 90 -warning 3
```

The following example configures a password expiration policy for all users.

```
switch:admin> passwdcfg --set -minpasswordage 5 -maxpasswordage 30 -warning 5
```

## Account lockout policy

The account lockout policy disables a user account when that user exceeds a specified number of failed login attempts, and is enforced across all user accounts. You can configure this policy to keep the account locked until explicit administrative action is taken to unlock it, or the locked account can be automatically unlocked after a specified period. Administrators can unlock a locked account at any time.

A failed login attempt counter is maintained for each user on each switch instance. The counters for all user accounts are reset to zero when the account lockout policy is enabled. The counter for an individual account is reset to zero when the account is unlocked after a lockout duration period expires, or when the account user logs in successfully.

The admin account can also have the lockout policy enabled on it. The admin account lockout policy is disabled by default and uses the same lockout threshold as the other permissions. It can be automatically unlocked after the lockout duration passes or when it is manually unlocked by either a user account that has a securityAdmin or other admin permissions.

**Virtual Fabrics considerations:** The home logical fabric context is used to validate user enforcement for the account lockout policy.

Note that the account-locked state is distinct from the account-disabled state.

Use the following attributes to set the account lockout policy:

- **LockoutThreshold**

Specifies the number of times a user can attempt to log in using an incorrect password before the account is locked. The number of failed login attempts is counted from the last successful login. LockoutThreshold values range from 0 through 999, and the default value is 0. Setting the value to 0 disables the lockout mechanism.

- **LockoutDuration**

Specifies the time, in minutes, after which a previously locked account is automatically unlocked. LockoutDuration values range from 0 through 99999, and the default value is 30. Setting the value to 0 disables lockout duration, and requires a user to seek administrative action to unlock the account. The lockout duration begins with the first login attempt after the LockoutThreshold has been reached. Subsequent failed login attempts do not extend the lockout period.

## Enabling the admin lockout policy

1. Log in to the switch using an account that has admin or securityAdmin permissions.
2. Enter the `passwdCfg --enableadminlockout` command.

## Unlocking an account

1. Log in to the switch using an account that has admin or securityAdmin permissions.
2. Enter the `userConfig --change account_name -u` command, specifying the `-u` option to unlock the account.

## Disabling the admin lockout policy

1. Log in to the switch using an account that has admin or securityAdmin permissions.
2. Enter the `passwdCfg --disableadminlockout` command.

## Denial of service implications

The account lockout mechanism may be used to create a denial of service condition when a user repeatedly attempts to log in to an account by using an incorrect password. Selected privileged accounts are exempted from the account lockout policy to prevent users from being locked out from a denial of service attack. However, these privileged accounts may then become the target of password-guessing attacks. Audit logs should be examined to monitor if such attacks are attempted.

## Changing the root password without the old password

Starting with Fabric OS 7.4.0, in environments where switch account passwords are controlled by password management appliances, you can configure an option to not verify the old password while changing the root password. By default, this option is disabled, which means that you must provide the old password to change the root password.

To disable verification of the old password, complete the following steps:

1. Use the **passwdcfg --set -oldpasswd {1 | 0}** command.
  - 1 enables the option; the old password is not required to change the root password.
  - 0 disables the option; the old password is required to change the root password.

```
switch:root> passwdcfg --set -oldpasswd 1
```

2. Enter the **passwd** command to change the root password.

```
Switch:root> passwd
Warning: Access to the Root account may be required for
Proper support of the switch. Please ensure the Root Passwords
are documented in a secure location. Recovery of a lost Root
password will result in fabric downtime.
Changing password for root
Enter new password:
```

The **-oldpasswd** configuration is discarded when you downgrade to any version prior to Fabric OS 7.4.0. The **-oldpasswd** configuration is retained when you upload the switch configuration or upgrade to a later version of Fabric OS.

## Configuring the password hash type

Fabric OS prior to 8.0.1 uses MD5 hash type for storing the local user passwords. Starting with Fabric OS 8.0.1, SHA256 and SHA512 hash types are also supported. Whenever you change the hash type, you will be prompted to change the password in the next log in. You can also use the **manual** option to manually trigger a password change immediately after the hash type configuration.

After a new password hash configuration, by default, you are forced to change the password in the next login. When the **-manual** option is used, you can change the password using the **password** command.

To change the password hash type, complete the following steps:

1. Login with the device using the username and password.
2. Enter the **passwdcfg --hash {md5/sha256/sha512} [-manual]** command to configure the hash type for the logged in user's password.
3. Enter the new password and confirm the same.
4. Use the following commands to display the password hash type for the current user, any user, or all users configured in the device.
  - Use the **passwdcfg -showhash** command to display the configured hash type on the switch.
  - Use the **passwdcfg -showhash username** command to display the current password hash for the username.
  - Use the **passwdcfg -showhash -all** to display the current password has for all the users on the switch.

Sample output:

```
switch(mode)# passwdcfg --hash sha256 -manual
switch(mode)# Enter the new password:
Confirm the new password:
switch(mode)# passwdcfg -showhash -all
<Command output>
```



- When a password database update is received, the hash type is not reset if the received hash configuration is weaker than existing hash configuration. For example, if the switch is currently using SHA512, and the configuration request is for SHA256 by **distribute** command, then the hash type is retained as SHA512.
- When you upgrade the switch to Fabric OS 8.0.1 or later, the MD5 hash type configuration is retained.
- When you downgrade the switch from Fabric OS 8.0.1, the downgrade is blocked unless the following two conditions are met.
  - The password hash type for all the users are changed to MD5.
  - The switch hash type is changed to MD5.

If the above two conditions are met but the password history consists of non-MD5 for any user, then the following message is prompted during firmware downgrade.

```
" WARNING !!!!! Password hash in the history contains non-MD5 hash for user(s) which must be cleared
to proceed with downgrade. Please confirm with [Y/N] to proceed further, when prompted for.
System settings check passed.
```

```
You can run firmwaredownloadstatus to get the status of this command.
```

```
This command will cause a warm/non-disruptive boot but will require that existing telnet, secure
telnet or SSH sessions be restarted.
```

```
Do you want to continue (Y/N) [Y]:"
```

- When you do a net install, all the password hash types are set to SHA512.



#### WARNING

You can use the **passwddefault** to reset all the password hash types to SHA512 and reset all the passwords to default.

## The boot PROM password

The boot PROM password provides an additional layer of security by protecting the boot PROM from unauthorized use. Setting a recovery string for the boot PROM password enables you to recover a lost boot PROM password by contacting your switch service provider. Without the recovery string, a lost boot PROM password cannot be recovered.

Although you can set the boot PROM password without also setting the recovery string, it is strongly recommended that you set both the password and the recovery string. If your site procedures dictate that you set the boot PROM password without the recovery string, refer to [Setting the boot PROM password for a switch without a recovery string](#) on page 159.

To set the boot PROM password with or without a recovery string, refer to the section that applies to your switch or Backbone model.



#### CAUTION

Setting the boot PROM password requires accessing the boot prompt, which stops traffic flow through the switch until the switch is rebooted. Perform this procedure during a planned downtime.

## Setting the boot PROM password for a switch with a recovery string

This procedure applies to the fixed-port switch models. The password recovery instructions provided within this section are only for the switches listed in supported hardware section. If your switch is not listed, contact your switch support provider for instructions.

1. Connect to the serial port interface as described in [Connecting to Fabric OS through the serial port](#) on page 38.
2. Reboot the switch.
3. Press **Esc** within four seconds after the message "Press escape within 4 seconds..." is displayed.
4. When prompted, enter **2** to select the recovery password option.

- If no password was previously set, the following message is displayed:

```
Recovery password is NOT set. Please set it now.
```

- If a password was previously set, the following messages is displayed:

```
Send the following string to Customer Support for password recovery:
afHTpyLsDo1Pz0Pk5GzhIw==
Enter the supplied recovery password.
Recovery Password:
```

5. Enter the recovery password (string).

The recovery string must be from 8 through 40 alphanumeric characters in length. A random string that is 15 characters or longer is recommended for higher security. The firmware prompts for this password only once. It is not necessary to remember the recovery string, because it is displayed the next time you enter the command shell.

The following prompt is displayed:

```
New password:
```

6. Enter the boot PROM password, and then re-enter it when prompted. The password must be eight alphanumeric characters long (any additional characters are not recorded). Record this password for future use.

The new password is automatically saved.

7. Reboot the switch by entering the **reset** command at the prompt.

## Setting the boot PROM password for a Backbones and Directors with a recovery string

This procedure applies to the Brocade DCX 8510 Backbones and X6 Directors. The boot PROM and recovery passwords must be set for each CP blade.

1. Connect to the serial port interface on the standby CP blade, as described in [Connecting to Fabric OS through the serial port](#) on page 38.
2. Connect to the active CP blade over a serial or Telnet connection and enter the **haDisable** command to prevent failover during the remaining steps.
3. Reboot the standby CP blade by sliding the On/Off switch on the ejector handle of the standby CP blade to **Off**, and then back to **On**.
4. Press **Esc** within four seconds after the message "Press escape within 4 seconds..." is displayed.
5. When prompted, enter **2** to select the recovery password option.

- If no password was previously set, the following message is displayed:

```
Recovery password is NOT set. Please set it now.
```

- If a password was previously set, the following messages are displayed:

```
Send the following string to Customer Support for password recovery:
afHTpyLsDo1Pz0Pk5GzhIw==
Enter the supplied recovery password.
Recovery Password:
```

6. Enter the recovery password (string).

The recovery string must be from 8 through 40 alphanumeric characters in length. A random string that is 15 characters or longer is recommended for higher security. The firmware only prompts for this password once. It is not necessary to remember the recovery string because it is displayed the next time you enter the command shell.

The following prompt is displayed:

```
New password:
```

7. Enter the boot PROM password, and then re-enter it when prompted. The password must be eight alphanumeric characters long (any additional characters are not recorded). Record this password for future use.

The new password is automatically saved (the **saveEnv** command is not required).

8. Connect to the active CP blade over a serial or Telnet connection and enter the **haEnable** command to restore high availability, and then fail over the active CP blade by entering the **haFailover** command.

Traffic flow through the active CP blade resumes when the failover is complete.

9. Connect the serial cable to the serial port on the new standby CP blade (previously the active CP blade).
10. Repeat step 2 through step 7 for the new standby CP blade (each CP blade has a separate boot PROM password).
11. Connect to the active CP blade over a serial or Telnet connection and enter the **haEnable** command to restore high availability.

Although you can set the boot PROM password without also setting the recovery string, it is strongly recommended that you set both the password and the string as described in [Setting the boot PROM password for a switch with a recovery string](#) on page 157. If your site procedures dictate that you must set the boot PROM password without the string, follow the procedure that applies to your switch model.

## Setting the boot PROM password for a switch without a recovery string

This procedure applies to fixed-port switches.

The password recovery instructions provided within this section are only for the switches listed in the supported hardware section. If your switch is not listed, contact your switch support provider for instructions.

1. Create a serial connection to the switch as described in [Connecting to Fabric OS through the serial port](#) on page 38.
2. Reboot the switch by entering the **reboot** command.
3. Press **Esc** within four seconds after the message "Press escape within 4 seconds..." is displayed.
4. When prompted, enter **3** to enter the command shell.
5. At the shell prompt, enter the **passwd** command.

The **passwd** command only applies to the boot PROM password when it is entered from the boot interface.

6. Enter the boot PROM password at the prompt, and then re-enter it when prompted. The password must be eight alphanumeric characters long (any additional characters are not recorded). Record this password for future use.
7. Enter the **saveEnv** command to save the new password.
8. Reboot the switch by entering the **reset** command.

## Setting the boot PROM password for a Backbone or Director without a recovery string

This procedure applies to the Brocade DCX 8510 Backbones and X6 Directors.

On the Brocade DCX 8510 Backbones, set the password on the standby CP blade, fail over, and then set the password on the previously active (now standby) CP blade to minimize disruption to the fabric.

1. Determine the active CP blade by opening a Telnet session to either CP blade, connecting as admin, and entering the **haShow** command.
2. Connect to the active CP blade over a serial or Telnet connection and enter the **haDisable** command to prevent failover during the remaining steps.

3. Create a serial connection to the standby CP blade as described in [Connecting to Fabric OS through the serial port](#) on page 38.
4. Reboot the standby CP blade by sliding the On/Off switch on the ejector handle of the standby CP blade to **Off**, and then back to **On**.

This causes the blade to reset.

5. Press **Esc** within four seconds after the message "Press escape within 4 seconds..." is displayed.
6. When prompted, enter **3** to enter the command shell.
7. Enter the **passwd** command at the shell prompt.

The **passwd** command applies only to the boot PROM password when it is entered from the boot interface.

8. Enter the boot PROM password at the prompt, and then re-enter it when prompted. The password must be eight alphanumeric characters long (any additional characters are not recorded). Record this password for future use.
9. Enter the **saveEnv** command to save the new password.
10. Reboot the standby CP blade by entering the **reset** command.
11. Connect to the active CP blade over a serial or Telnet connection and enter the **haEnable** command to restore high availability, and then fail over the active CP blade by entering the **haFailover** command.

Traffic resumes flowing through the newly active CP blade after it has completed rebooting.

12. Connect the serial cable to the serial port on the new standby CP blade (previously the active CP blade).
13. Repeat step 3 through step 10 for the new standby CP blade.
14. Connect to the active CP blade over a serial or Telnet connection and enter the **haEnable** command to restore high availability.

#### NOTE

To recover lost passwords, refer to the *Fabric OS Troubleshooting and Diagnostics Guide*.

## Remote authentication

Fabric OS supports user authentication through the local user database or one of the following external authentication services:

- Remote authentication dial-in user service (RADIUS)
- Lightweight Directory Access Protocol (LDAP) using Microsoft Active Directory in Windows or OpenLDAP in Linux.
- LDAP is supported with Windows 2008-2012 running LDAP 2003-2008 schema.
- Terminal Access Controller Access-Control System Plus (TACACS+)

## Remote authentication configuration

A switch can be configured to try one of the supported remote authentication services (RADIUS, LDAP, or TACACS+) and local switch authentication. The switch can also be configured to use only a remote authentication service, or only local switch authentication.

### Client/server model

When configured to use one of the supported remote authentication services, the switch acts as a Network Access Server (NAS) and RADIUS, LDAP, or TACACS+ client. The switch sends all authentication, authorization, and accounting (AAA) service requests to the authentication server. The authentication server receives the request, validates the request, and sends its response back to the switch.

The supported management access channels that integrate with RADIUS, LDAP, and TACACS+ include serial port, Telnet, SSH, and Web Tools. All these access channels require the switch IP address or name to connect. RADIUS, LDAP, and TACACS+ servers accept both IPv4 and IPv6 address formats. For accessing both the active and standby CP blades, and for the purpose of HA failover, both CP IP addresses of a Backbone should be included in the authentication server configuration.

**NOTE**

For systems such as the Brocade DCX Backbone, the switch IP addresses are aliases of the physical Ethernet interfaces on the CP blades. When specifying client IP addresses for the logical switches in such systems, make sure that the CP IP addresses are used.

## Authentication server data

When configured for remote authentication, a switch becomes a RADIUS, LDAP, or TACACS+ client. In any of these configurations, authentication records are stored in the authentication host server database. Login and logout account name, assigned permissions, and time-accounting records are also stored on the authentication server for each user.

## Switch configuration

By default, the remote authentication services are disabled, so AAA services default to the switch's local database.

To enable remote authentication, it is strongly recommended that you access the CLI through an SSH connection so that the shared secret is protected. Multiple login sessions can configure simultaneously, and the last session to apply a change leaves its configuration in effect. After a configuration is applied, it persists after a reboot or an HA failover.

To enable the secure LDAP service, you must install a certificate from the Microsoft Active Directory server or the OpenLDAP server. By default, the LDAP service does not require certificates.

The configuration applies to all switches. On a Backbone, the configuration replicates itself on a standby CP blade if one is present. It is saved in a configuration upload and applied in a configuration download.

Brocade recommends configuring at least two authentication servers, so that if one fails, the other will assume service. Up to five servers are supported.

You can set the configuration with any one of the supported authentication services and local authentication enabled, so that if the authentication servers do not respond because of a power failure or network problems, the switch uses local authentication.

Consider the effects of the use of a remote authentication service on other Fabric OS features. For example, when a remote authentication service is enabled, all account passwords must be managed on the authentication server. The Fabric OS mechanisms for changing switch passwords remain functional; however, such changes affect only the involved switches locally. They do not propagate to the authentication server, nor do they affect any account on the authentication server. Authentication servers also support notifying users of expiring passwords.

When RADIUS, LDAP, or TACACS+ is set up for a fabric that contains a mix of switches with and without RADIUS, LDAP, and TACACS+ support, the way a switch authenticates users depends on whether a RADIUS, LDAP, or TACACS+ server is set up for that switch. For a switch with remote authentication support and configuration, authentication bypasses the local password database. For a switch without remote authentication support or configuration, authentication uses the switch's local account names and passwords.

## Supported LDAP options

The following table summarizes the various LDAP options and Brocade support for each.

**TABLE 24** LDAP options

Protocol	Description	Channel type	Default port	URL	Brocade supported?
LDAPv3	LDAP over TCP	Unsecured	389	ldap://	No
LDAPv3 with TLS extension	LDAPv3 over TLS	Secured	389	ldap://	Yes
LDAPv3 with TLS and Certificate	LDAPv3 over TLS channel and	Secured	389	ldap://	Yes

**TABLE 24** LDAP options (continued)

Protocol	Description	Channel type	Default port	URL	Brocade supported?
	authenticated using a certificate				
LDAPv2 with SSL <sup>1</sup>	LDAPv2 over SSL. Port 636 is used for SSL. Port 389 is for connecting to LDAP.	Secured	636 and 389	ldaps://	No

## Command options

The following table outlines the *aaaConfig* command options used to set the authentication mode.

**TABLE 25** Authentication configuration options

aaaConfig options	Description
--authspec "local"	Default setting. Authenticates management connections against the local database only. If the password does not match or the user is not defined, the login fails.
--authspec "radius"	Authenticates management connections against any RADIUS databases only. If the RADIUS service is not available or the credentials do not match, the login fails.
--authspec "radius:local"	Authenticates management connections against any RADIUS databases first. If RADIUS fails <i>for any reason</i> , authenticates against the local user database.
--authspec "radius:local" --backup	Authenticates management connections against any RADIUS databases. If RADIUS fails because the service is not available, it then authenticates against the local user database. The <b>--backup</b> option directs the service to try the secondary authentication database only if the primary authentication database is not available.
--authspec "ldap"	Authenticates management connections against any LDAP databases only. If LDAP service is not available or the credentials do not match, the login fails.
--authspec "ldap; local"	Authenticates management connections against any LDAP databases first. If LDAP fails for any reason, it then authenticates against the local user database.
--authspec "ldap; local" -backup	Authenticates management connections against any LDAP databases first. If LDAP fails for any reason, it then authenticates against the local user database. The <b>--backup</b> option states to try the secondary authentication database only if the primary authentication database is not available.
--authspec "tacacs+"	Authenticates management connections against any TACACS+ databases only. If TACACS+ service is not available or the credentials do not match, the login fails.
--authspec "tacacs+; local"	Authenticates management connections against any TACACS+ databases first. If TACACS+ fails for any reason, it then authenticates against the local user database.

<sup>1</sup> This protocol was deprecated in 2003 when LDAPv3 was standardized.

**TABLE 25** Authentication configuration options (continued)

aaaConfig options	Description
--authspec "tacacs+; local" --backup	Authenticates management connections against any TACACS+ databases first. If TACACS+ fails for any reason, it then authenticates against the local user database. The <b>--backup</b> option states to try the secondary authentication database only if the primary authentication database is not available.
--authspec -nologout	Prevents users from being logged out when you change authentication. Default behavior is to log out users when you change authentication.

## Setting the switch authentication mode

1. Connect to the switch and log in using an account with admin permissions.
2. Enter the **aaaConfig --authspec** command.

## Fabric OS user accounts

RADIUS, LDAP, and TACACS+ servers allow you to set up user accounts by their true network-wide identities rather than by the account names created on a Fabric OS switch. With each account name, assign the appropriate switch access permissions. For LDAP servers, you can use the **ldapCfg --maprole** command to map LDAP server permissions.

RADIUS, LDAP, and TACACS+ support all the defined RBAC roles described in [Role-Based Access Control](#) on page 145.

Users must enter their assigned RADIUS, LDAP, or TACACS+ account name and password when logging in to a switch that has been configured with remote authentication. After the remote authentication (RADIUS, LDAP, or TACACS+) server authenticates a user, it responds with the assigned switch role in a *Brocade Vendor-Specific Attribute* (VSA). If the response does not have a VSA permissions assignment, the user role is assigned.

You can set a user password expiration date and add a warning for RADIUS login and TACACS+ login. The password expiry date must be specified in UTC and in MM/DD/YYYY format. The password warning specifies the number of days prior to the password expiration that a warning of password expiration notifies the user. You either specify both attributes or none. If you specify a single attribute or there is a syntax error in the attributes, the password expiration warning will not be issued. If your RADIUS server maintains its own password expiration attributes, you must set the exact date *twice* to use this feature, once on your RADIUS server and once in the VSA. If the dates do not match, then the RADIUS server authentication fails.

[Table 26](#) describes the syntax used for assigning VSA-based account switch roles on a RADIUS server.

**TABLE 26** Syntax for VSA-based account roles

Item	Value	Description
Type	26	1 octet
Length	7 or higher	1 octet, calculated by the server
Vendor ID	1588	4 octet, Brocade SMI Private Enterprise Code
Vendor type	1	1 octet, Brocade-Auth-Role; valid attributes for the Brocade-Auth-Role are:  Admin  BasicSwitchAdmin  FabricAdmin  Operator  SecurityAdmin  SwitchAdminUser

TABLE 26 Syntax for VSA-based account roles (continued)

Item	Value	Description
		ZoneAdmin
	2	<i>Optional:</i> Specifies the Virtual Fabric member list. For more information on Virtual Fabrics, refer to <a href="#">RADIUS configuration with Virtual Fabrics</a> on page 166. Brocade-AVPairs1
	3	Brocade-AVPairs2
	4	Brocade-AVPairs3
	5	Brocade-AVPairs4
	6	Brocade Password ExpiryDate
	7	Brocade Password ExpiryWarning
Vendor length	2 or higher	1 octet, calculated by server, including vendor-type and vendor-length
Attribute-specific data	ASCII string	Multiple octet, maximum 253, indicating the name of the assigned role and other supported attribute values.

## Fabric OS users on the RADIUS server

All existing Fabric OS mechanisms for managing local-switch user accounts and passwords remain functional when the switch is configured to use RADIUS. Changes made to the local switch database do not propagate to the RADIUS server, nor do the changes affect any account on the RADIUS server.

## Windows 2012 IAS

To configure a Windows 2012 Internet authentication service (IAS) server to use VSA to pass the admin role to the switch in the dial-in profile, the configuration specifies the Vendor code (1588), Vendor-assigned attribute number (1), and attribute value (admin), as shown in the below figure.



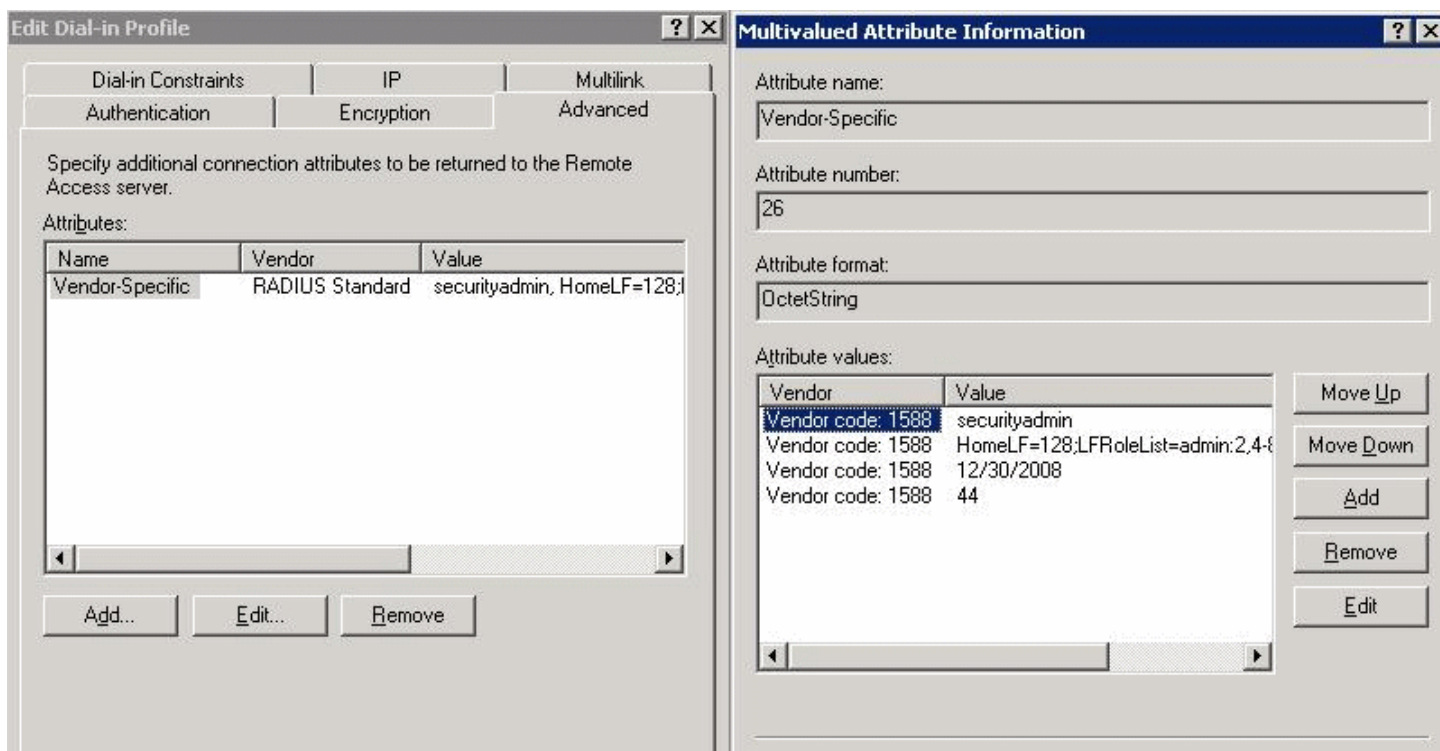

Windows 2012 VSA configuration

### Linux FreeRADIUS server

For the configuration on a Linux FreeRADIUS server, define the values outlined in [Table 27](#) in a vendor dictionary file called dictionary.brocade.

**TABLE 27** Entries in dictionary.brocade file

Include	Key	Value
VENDOR	Brocade	1588
ATTRIBUTE	Brocade-Auth-Role	1 string Brocade
	Brocade-AVPairs1, 2, 3, 4	2, 3, 4, 5 string Virtual Fabric member list
	Brocade-Passwd-ExpiryDate	6 string MM/DD/YYYY in UTC
	Brocade-Passwd-WarnPeriod	7 integer in days

After you have completed the dictionary file, define the permissions for the user in a configuration file. For example, to grant the user admin permissions, you would add the following statement to the configuration file:

```
swladmin      Auth-Type := Local, User-Password == "myPassword"
              Brocade-Auth-Role = "admin",
              Brocade-AVPairs1 = "HomeLF=70",
              Brocade-AVPairs2 = "LFRoleList=admin:2,4-8,70,80,128;ChassisRole=admin",
              Brocade-Passwd-ExpiryDate = "11/10/2011",
              Brocade-Passwd-WarnPeriod = "30"
```

## RADIUS configuration with Virtual Fabrics

When configuring users with Virtual Fabrics, you must also include the Virtual Fabric member list. This section describes the way that you configure attribute types for this configuration.

The values for these attribute types use the syntax `key=val[:key=val]`, where `key` is a text description of attributes, `val` is the attribute value for the given key, the equal sign (=) is the separator between key and value, and the semicolon (;) is an optional separator for multiple key-value pairs.

Multiple key-value pairs can appear for one Vendor-Type code. Key-value pairs with the same key name may be concatenated across multiple Vendor-Type codes. You can use any combination of the Vendor-Type codes to specify key-value pairs. Note that a switch always parses these attributes from *Vendor-Type code 2* to *Vendor-Type code 4*.

Only the following keys are accepted; all other keys are ignored.

- **HomeLF** is the designated home Virtual Fabric for the account. The valid values are from 1 through 128 and chassis context. The first valid HomeLF key-value pair is accepted by the switch; additional HomeLF key-value pairs are ignored.
- **LFRoleList** is a comma-separated list of Virtual Fabric ID numbers of which this account is a member. Valid numbers range from 1 through 128. A dash between two numbers specifies a range. Multiple Virtual Fabric list key-value pairs within the same or across different Vendor-Type codes are concatenated. Multiple occurrences of the same Virtual Fabric ID number are ignored.
- **ChassisRole** is the account access permission at the chassis level. The chassis role allows the user to execute chassis-related commands in a Virtual Fabrics-enabled environment. Valid chassis roles include the default roles and any of the user-defined roles.

RADIUS authentication requires that the account have valid permissions through the attribute type Brocade-Auth-Role. The additional attribute values HomeLF and LFRoleList are optional. If they are unspecified, the account can log in with VF128 as its member list and home Virtual Fabric. If there is an error in the LFRoleList or HomeLF specification, the account cannot log in until the Virtual Fabric list is corrected; an error message is displayed.

In the next example, on a Linux FreeRADIUS Server, the user has the "zoneAdmin" permissions, with VFlist 2, 4, 5, 6, 7, 8, 10, 11, 12, 13, 15, 17, 19, 22, 23, 24, 25, 29, 31 and HomeLF 1.

```
user300 Auth-Type := Local, User-Password == "password"
Brocade-Auth-Role = "zoneadmin",
Brocade-AVPairs1 = "HomeLF=1;LFRoleList=securityadmin:2,4-8,10"
Brocade-AVPairs2 = "LFRoleList=admin:11-13, 15, 17, 19;user:22-25,29,31"
Brocade-AVPairs3 = "ChassisRole=switchadmin"
```

## Setting up a RADIUS server

### NOTE

To set up the RADIUS server, you must know the switch IP address (in either IPv4 or IPv6 notation) or the name to connect to switches. Use the **ipAddrShow** command to display a switch IP address.

For Brocade Backbones, the switch IP addresses are aliases of the physical Ethernet interfaces on the CP blades. When specifying client IP addresses for the logical switches in these systems, make sure the CP blade IP addresses are used. For accessing both the active and standby CP blades, and for the purpose of HA failover, both of the CP blade IP addresses must be included in the RADIUS server configuration.

User accounts should be set up by their true network-wide identities rather than by the account names created on a Fabric OS switch. Along with each account name, the administrator must assign appropriate switch access permissions. To manage a fabric, set these permissions to user, admin, and securityAdmin.

**NOTE**

The combination of "peap-mschapv2" and IPv6 when used together, rejects RADIUS authentication. PEAP with IPv4 succeeds. Combination of PEAP-MSCHAPv2 and IPv6 is not supported and hence blocked during configuration.

## Configuring RADIUS server support with Linux

The following procedures work for FreeRADIUS on Solaris and Red Hat Linux. FreeRADIUS is a freeware RADIUS server that you can find at the following website:

<http://www.freeradius.org>

Follow the installation instructions at the website. FreeRADIUS runs on Linux (all versions), FreeBSD, NetBSD, and Solaris. If you make a change to any of the files used in this configuration, you must stop the server and restart it for the changes to take effect.

FreeRADIUS installation places the configuration files in `$PREFIX/etc/raddb`. By default, the PREFIX is `/usr/local`.

Configuring RADIUS service on Linux consists of the following tasks:

- Adding the Brocade attributes to the server
- Creating the user
- Enabling clients

### Adding the Brocade attributes to the server

1. Create and save the file `$PREFIX/etc/raddb/dictionary.brocade` with the following information:

```
# dictionary.brocade
#
VENDOR Brocade 1588
#
# attributes
#
ATTRIBUTE      Brocade-Auth-Role      1      string  Brocade
ATTRIBUTE      Brocade-AVPairs1        2      string  Brocade
ATTRIBUTE      Brocade-AVPairs2        3      string  Brocade
ATTRIBUTE      Brocade-AVPairs3        4      string  Brocade
ATTRIBUTE      Brocade-AVPairs4        5      string  Brocade
ATTRIBUTE      Brocade-Passwd-ExpiryDate 6      string  Brocade
ATTRIBUTE      Brocade-Passwd-WarnPeriod 7      string  Brocade
```

This information defines the Brocade vendor ID as 1588, Brocade attribute 1 as Brocade-Auth-Role, Brocade attribute 6 as Brocade-Passwd-ExpiryDate, and Brocade attribute 7 as Brocade-Passwd-WarnPeriod.

2. Open the file `$PREFIX/etc/raddb/dictionary` in a text editor and add the line:

```
$INCLUDE dictionary.brocade
```

As a result, the file `dictionary.brocade` is located in the RADIUS configuration directory and loaded for use by the RADIUS server.

### Creating the user

1. Open the `$PREFIX/etc/raddb/user` file in a text editor.
2. Add the user names and their permissions for users accessing the switch and authenticating through RADIUS.

The user logs in using the permissions specified with Brocade-Auth-Role. The valid permissions include root, admin, switchAdmin, zoneAdmin, securityAdmin, basic SwitchAdmin, fabricAdmin, operator, and user. You must use quotation marks around "password" and "role".

### Example of adding a user name to the RADIUS authentication

For example, to set up an account called JohnDoe with admin permissions with a password expiry date of May 28, 2008 and a warning period of 30 days:

```
JohnDoe Auth-Type := Local
User-Password == "johnPassword",
Brocade-Auth-Role = "admin",
Brocade-Passwd-ExpiryDate = "05/28/08",
Brocade-Passwd-WarnPeriod = "30"
```

### Example of using the local system password to authenticate users

The following example uses the local system password file to authenticate users.

```
Auth-Type := System
Brocade-Auth-Role = "admin",
Brocade-AVPairs1 = "HomeLF=70",
Brocade-AVPairs2 = "LFRoleList=admin:2,4-8,70,80,128",
Brocade-AVPairs3 = "ChassisRole=switchadmin",
Brocade-Passwd-ExpiryDate = "11/10/2008",
Brocade-Passwd-WarnPeriod = "30"
```

When you use network information service (NIS) for authentication, the only way to enable authentication with the password file is to force the Brocade switch to authenticate using Password Authentication Protocol (PAP); this requires the **-a pap** option with the **aaaConfig** command.

## Enabling clients

Clients are the switches that will use the RADIUS server; each client must be defined. By default, all IP addresses are blocked.

The Brocade Backbones send their RADIUS requests using the IP address of the active CP. When adding clients, add both the active and standby CP IP addresses so that, in the event of a failover, users can still log in to the switch.

1. Open the `$(PREFIX)/etc/raddb/client.config` file in a text editor and add the switches that are to be configured as RADIUS clients.

For example, to configure the switch at IP address 10.32.170.59 as a client:

```
client 10.32.170.59
secret      = Secret
shortname   = Testing Switch
nastype     = other
```

In this example, *shortname* is an alias used to easily identify the client. *Secret* is the shared secret between the client and server. Make sure the shared secret matches that configured on the switch (refer to [Adding an authentication server to the switch configuration](#) on page 182).

2. Save the file `$(PREFIX)/etc/raddb/client.config`, and then start the RADIUS server as follows:

```
$(PREFIX)/sbin/radiusd
```

## Configuring RADIUS server support with Windows 2012

The instructions for setting up RADIUS on a Windows 2012 server are listed here for your convenience but are not guaranteed to be accurate for your network environment. Always check with your system administrator before proceeding with setup.

### NOTE

All instructions involving Microsoft Windows 2012 can be obtained from [www.microsoft.com](http://www.microsoft.com) or your Microsoft documentation. Confer with your system or network administrator prior to configuration for any special needs your network environment may have.

Configuring RADIUS service on Windows 2012 consists of the following steps:

1. Installing Internet Authentication Service (IAS)

For more information and instructions on installing IAS, refer to the Microsoft website.

2. Enabling the Challenge Handshake Authentication Protocol (CHAP)

If CHAP authentication is required, then Windows must be configured to store passwords with reversible encryption. Reverse password encryption is not the default behavior; it must be enabled.

#### NOTE

If a user is configured prior to enabling reverse password encryption, then the user's password is stored and cannot utilize CHAP. To use CHAP, the password must be re-entered after encryption is enabled. If the password is not re-entered, then CHAP authentication will not work and the user will be unable to authenticate from the switch. Alternatives to using CHAP are Password Authentication Protocol (PAP), or PEAP-MSCHAPv2.

3. Configuring a user

IAS is the Microsoft implementation of a RADIUS server and proxy. IAS uses the Windows native user database to verify user login credentials; it does not list specific users, but instead lists *user groups*. Each user group should be associated with a specific switch role. For example, you should configure a user group for root, admin, switchAdmin, and user, and then add any users whose logins you want to associate to the appropriate group.

4. Configuring the server

For more information and instructions on configuring the server, refer to the Microsoft website. You will need the following information to configure the RADIUS server for a Brocade switch. A client is the device that uses the RADIUS server; in this case, it is the switch.

5. **Check if Active Directory Users and Computers tool is available.** If not, select Server Manager > Manager tab > Add Roles and Feature.

The Add Role and Feature wizard is displayed. Follow these steps to install Active Directory Users and Computers.

- a) Select Installation Type from the left pane and choose the Role-based or feature-based Installation option
- b) Select Server Selection from the left pane and choose the Select a server from the server pool option
- c) Select the server from the list displayed and click Next.  
The Features tab is displayed.
- d) From the Features tab, select all the checkboxes starting from the Remote Server Administration Tools checkbox till the AD DS Snap-Ins and Command-Line Tools element checkbox in the navigation tree.
- e) From the Feature tab, select the Group Policy Management checkbox, and then click Next.  
The Confirmation tab is displayed.
- f) Select the Restart the destination server automatically if required checkbox and click Finish.

6. **Check if the switch is part of RADIUS client.** If not, select Administrative tools > Network policy server > Radius clients and Servers > Radius client from the menu. Right click and add the switch IP address as Radius client.

Client address (IP or DNS) -- Enter the IP address of the switch.

Client-Vendor -- Select **RADIUS Standard**.

Shared secret -- Provide a password. Shared secret is a password used between the client device and server to prevent IP address spoofing by unwanted clients. Keep your shared secret password in a safe place. You will need to enter this password in the switch configuration.

After clicking **Finish**, add a new client for all switches on which RADIUS authentication will be used.

- a) In the Internet Authentication Service window, right-click the Remote Access Policies folder, and then select **New Remote Access Policy** from the pop-up window.  
A remote access policy must be created for each group of Brocade login permissions (root, admin, switchAdmin, and user) for which you want to use RADIUS. Apply this policy to the user groups that you already created.
  - b) In the Vendor-Specific Attribute Information window, enter the vendor code value **1588** . Click the **Yes, It conforms** option, and then click **Configure Attribute** .
  - c) In the Configure VSA (RFC compliant) window, enter the following values, and then click **OK** .  
Vendor-assigned attribute number -- Enter the value **1** .  
Attribute format -- Enter **String** .  
Attribute value -- Enter the login role (root, admin, switchAdmin, user, and so on) that the user group must use to log in to the switch.
  - d) After returning to the Internet Authentication Service window, add additional policies for all Brocade login types for which you want to use the RADIUS server. After this is done, you can configure the switch.
7. **Add Admin group and CHAP/PAP/PEAP group before adding the user.** To add Admin group in Active Directory User and Computers, follow these steps:
- a) In Server Manager, open AD DS tab and then open Active Directory User and Computers.
  - b) Right-click on the left panel tab and select New > Group from the menu.  
The New Object - Group dialog box is displayed.
  - c) Enter the Group name as "admin". Select the Group scope as Global and Group type as Security and then click OK.  
The admin Properties window displayed.
  - d) Enter the Description as "FOS admin role" and click Apply.
- i
8. **Add CHAP group in Active Directory Users and Computers.** To add CHAP group, follow these steps:
- a) In Server Manager, open AD DS tab and then open Active Directory User and Computers.
  - b) Right-click on the left panel tab and select New > Group from the menu.  
The New Object - Group dialog box is displayed.
  - c) Enter the Group name as "chap". Select the Group scope as Global and Group type as Security and then click OK.  
The chap Properties window displayed.
  - d) Enter the Description as "FOS chap group" and click Apply.
9. **Define a CHAP policy for CHAP group users.** To define the CHAP policy, follow these steps:
- a) Open the Administrative tools > Network policy server > Policies > Network Policies from the menu bar.
  - b) Right-click and select New.  
The New Network Policy dialog box is displayed.
  - c) Enter the policy name as "swchap". Select the Type of network access server as Unspecified and click Next.
  - d) Click Add and then select the Windows Groups from the list.  
The Select Group dialog box is displayed.
  - e) Enter the object name to select as "chap" and then click OK. Click Next.  
The Specify Access Permission window is displayed.
  - f) Select the Access granted option and click Next.  
The Configure Authentication Methods window is displayed.
  - g) Select the Encrypted authentication (CHAP) check box and click Next.

The Configure Settings window is displayed.

- h) Select the Vendor Specific option from the left pane and click Add.  
The Add Vendor Specific Attribute dialog box is displayed.
  - i) Select RADIUS Standard from the list and click Add.  
The Vendor Specific Attribute Information dialog box is displayed.
  - j) Select RADIUS Standard from the list and choose the Yes, it confirms option. Click Ok.  
The Configure VSA (RFC Compliant) dialog box is displayed.
  - k) Select the Vendor assigned attribute number, Attribute format as String, and Attribute value as "admin" and then click OK.
  - l) Click Finish.
10. **Add new Radius user with CHAP authentication.** To add a Radius user follow these steps:
- a) In Server Manager, open AD DS tab and then open Active Directory User and Computers.
  - b) Right-click on the left panel tab and select New > User from the menu.  
The New Object - User dialog box is displayed.
  - c) Enter First name and User Logon name as "swchap", select the server from the list and click Next.
  - d) Enter a password, confirm the password, and then click Next.
  - e) Click Finish, select the added user from the list.
  - f) Right-click and select Properties.  
The swchap Properties dialog box is displayed.
  - g) Select the Account tab and complete the details.
  - h) Select the Member of tab, click Add, and then add the user Role as admin. Apply changes and click Ok.
11. **Add new Radius user with PAP authentication.** To add a Radius user follow these steps:
- a) In Server Manager, open AD DS tab and then open Active Directory User and Computers.
  - b) Right-click on the left panel tab and select New > User from the menu.  
The New Object - User dialog box is displayed.
  - c) Enter First name and User Logon name as "swpap", select the server from the list and click Next.
  - d) Enter a password, confirm the password, and then click Next.
  - e) Click Finish, select the added user from the list.
  - f) Right-click and select Properties.  
The swpap Properties dialog box is displayed.
  - g) Select the Account tab and complete the details.
  - h) Select the Member of tab, click Add, Add the user Role as admin and PAP group member. Apply changes and click Ok.
12. Configure client for added user server and try to login with added user from client machine.

## RSA RADIUS server

Traditional password-based authentication methods are based on *one-factor* authentication, where you confirm your identity using a memorized password. Two-factor authentication increases the security by using a second factor to corroborate identification. The first factor is either a PIN or password and the second factor is the RSA SecurID token.

RSA SecurID with an RSA RADIUS server is used for user authentication. The Brocade switch does not communicate directly with the RSA Authentication Manager, so the RSA RADIUS server is used in conjunction with the switch to facilitate communication.

To learn more about how RSA SecurID works, visit [www.rsa.com](http://www.rsa.com) for more information.

## Setting up the RSA RADIUS server

For more information on how to install and configure the RSA Authentication Manager and the RSA RADIUS server, refer to your documentation or visit [www.rsa.com](http://www.rsa.com).

1. Create user records in the RSA Authentication Manager.
2. Configure the RSA Authentication Manager by adding an agent host.
3. Configure the RSA RADIUS server.

Setting up the RSA RADIUS server involves adding RADIUS clients, users, and vendor-specific attributes to the RSA RADIUS server.

- a) Add the following data to the `vendor.ini` file:

```
vendor-product = Brocade
dictionary = brocade
ignore-ports = no
port-number-usage = per-port-type
help-id = 2000
```

- b) Create a `brocade.dct` file that must be added into the `dictiona.dcm` file located in the following path:

```
C:\Program Files\RSA Security\RSA RADIUS\Service
```

Example of a `brocade.dct` file

```
#####
# brocade.dct -- Brocade Dictionary
#
# (See readme.dct for more details on the format of this file)
#####
#
# Use the Radius specification attributes in lieu of the Brocade one:
#
@radius.dct
MACRO Brocade-VSA(t,s) 26 [vid=1588 type1=%t len1=+2 data=%s]
ATTRIBUTE Brocade-Auth-Role Brocade-VSA(1,string) r
ATTRIBUTE Brocade-Passwd-ExpiryDate Brocade-VSA(6,string) r
ATTRIBUTE Brocade-Passwd-WarnPeriod Brocade-VSA(7,integer) r
#####
# brocade.dct -- Brocade Dictionary
#####
```

Example of the `dictiona.dcm` file

```
#####
# dictiona.dcm
#####
# Generic Radius
@radius.dct
#
# Specific Implementations (vendor specific)
#
@3comsw.dct
@aat.dct
@acc.dct
@accessbd.dct
@agere.dct
@agns.dct
@airespace.dct
@alcatel.dct
@altiga.dct
@annex.dct
```



```
@aptis.dct
@ascend.dct
@ascndvsa.dct
@axc.dct
@bandwagn.dct
@brocade.dct <-----
```

Example of a `brocade.dct` file shows what the `brocade.dct` file should look like and Example of the `dictionary.dcm` file shows what needs to be modified in the `dictionary.dcm` file.

#### NOTE

The dictionary files for the RSA RADIUS server must remain in the installation directory. Do not move the files to other locations on your computer.

- c) Add *Brocade-VSA macro* and define the attributes as follows:
  - vid (Vendor-ID): 1588
  - type1 (Vendor-Type): 1
  - len1 (Vendor-Length): >=2
- d) When selecting items from the **Add Return List Attribute**, select **Brocade-Auth-Role** and type the string **Admin**. The string you type equals the role on the switch.
- e) Add the Brocade profile.
- f) In **RSA Authentication Manager**, edit the user records that will be authenticated using RSA SecurID.

## Obfuscation of RADIUS shared secret

Starting with Fabric OS 7.4.0, you can store and display the RADIUS server shared secret either as plain text or in an encrypted format. For encrypting the RADIUS server shared secret, both the CPs in a chassis must be running Fabric OS 7.4.0 or later. If you choose to encrypt the RADIUS server shared secret, it is applied during the following operations:

- Set the configuration
- Upload configuration
- Download configuration
- Upload supportSave information
- Download supportSave information
- Upgrade firmware
  - When you upgrade to Fabric OS 7.4.0 or later, the RADIUS shared secret remains as plain text. You must explicitly set the encryption on.
  - When you downgrade to Fabric OS 7.3.0 or earlier, and then back to Fabric OS 7.4.0 or later, the encryption setting is unchanged.
- Downgrade firmware
  - If the shared secret encryption is set to on and you downgrade to an earlier version of Fabric OS 7.4.0, then you are prompted to set the encryption to either **none** or **aes256** before downgrading. You are also prompted to remove radius configurations and set the encryption level to none.
- The **show** command output

To enable encryption, use the **-e** or **-encr\_type** option in the following commands.

```
aaaconfig --add server -conf radius|ldap|tacacs+ [-p port] [-s secret] [-t timeout] [-d domain-name] [-a chap|pap|peap-mschapv2] [-e -encr_type encryption_level]
```

```
--change server -conf radius|ldap|tacacs+ [-p port] [-s secret] [-t timeout] [-a chap|pap|peap-
mschapv2] [-d domain-name] [-e -encr_type encryption_level]
```

#### NOTE

For **-conf ldap**, **-a**, **-s** and **-e** options are not applicable. For **-conf tacacs+**, **-e** option is not applicable.

## LDAP configuration and Microsoft Active Directory

LDAP provides user authentication and authorization using the Microsoft Active Directory service or using OpenLDAP in conjunction with LDAP on the switch. This section discusses authentication and authorization using Microsoft Active Directory. For information about authentication and authorization using OpenLDAP, refer to [LDAP configuration and OpenLDAP](#) on page 176.

Two operational modes exist in LDAP authentication, FIPS mode and non-FIPS mode. This section discusses LDAP authentication in non-FIPS mode. For more information on LDAP in FIPS mode, refer to [Configuring Security Policies](#) on page 215. The following are restrictions when using LDAP in non-FIPS mode:

- There is no password change through Active Directory.
- There is no automatic migration of newly created users from the local switch database to Active Directory. This is a manual process explained later.
- Only IPv4 is supported for LDAP on Windows 2000 and LDAP on Windows Server 2003. For LDAP on Windows Server 2008, both IPv4 and IPv6 are supported.
- LDAP authentication is used on the local switch only and not for the entire fabric.
- You can use the User-Principal-Name and not the Common-Name for AD LDAP authentication.

To provide backward compatibility, authentication based on the Common Name is still supported for Active Directory LDAP 2000 and 2003. Common Name-based authentication is not recommended for new installations.

- A user can belong to multiple groups as long as one of the groups is the primary group. The primary group in the AD server should not be set to the group corresponding to the switch role. You can choose any other group.
- A user can be part of any Organizational Unit (OU).

When authentication is performed by User-Principal-Name, in Fabric OS 71.0 and later releases, the suffix part of the name (the `@domain-name` part) can be omitted when the user logs in. If the suffix part of the User-Principal-Name name is omitted, the domain name configured for the LDAP server (in the `aaaConfig --add` command) is added and used for authentication purposes.

Roles for Brocade-specific users can be added through the Microsoft Management Console. Groups created in Active Directory must correspond directly to the RBAC user roles on the switch. Role assignments can be achieved by including the user in the respective group. A user can be assigned to multiple groups such as Switch Admin and Security Admin. For LDAP servers, you can use the `ldapCfg --maprole` command to map LDAP server permissions to one of the default roles available on a switch. For more information on RBAC roles, refer to [Role-Based Access Control](#) on page 145.

#### NOTE

All instructions involving Microsoft Active Directory can be obtained from [www.microsoft.com](http://www.microsoft.com) or your Microsoft documentation. Confer with your system or network administrator prior to configuration for any special needs your network environment may have.

## Configuring Microsoft Active Directory LDAP service

The following is an overview of the process used to set up LDAP.

1. If your Windows Active Directory server for LDAP needs to be verified by the LDAP client (that is, the Brocade switch), then you must install a Certificate Authority (CA) certificate on the Windows Active Directory server for LDAP.

Follow Microsoft instructions for generating and installing CA certificates on a Windows server.

2. Create a user in Microsoft Active Directory server.

For instructions on how to create a user, refer to [www.microsoft.com](http://www.microsoft.com) or Microsoft documentation to create a user in your Active Directory.

3. Create a group name that uses the switch's role name so that the Active Directory group's name is the same as the switch's role name.

or

Use the `ldapCfg --maprole ldap_role_name switch_role` command to map an LDAP server role to one of the default roles available on the switch.

4. Associate the user to the group by adding the user to the group.
5. Add the user's Virtual Fabrics to the CN\_list by either editing the `adminDescription` value or adding the `brcdAdvfData` attribute to the existing Active Directory schema.

This action maps the Virtual Fabrics to the user name. Virtual Fabrics are added as a string value separate by a comma ( , ) and entered as a range.

## Creating a user

To create a user in Active Directory, refer to [www.microsoft.com](http://www.microsoft.com) or Microsoft documentation. There are no special attributes to set. You can use a fully qualified name for logging in; for example, you can log in as "user@domain.com".

## Creating a group

To create a group in Active Directory, refer to [www.microsoft.com](http://www.microsoft.com) or Microsoft documentation. You must verify that the group has the following attributes:

- The name of the group must match the RBAC role.
- The Group Type must be **Security**.
- The Group Scope must be **Global**.
- The primary group in the AD server should not be set to the group corresponding to the switch role. You can choose any other group.
- If the user you created is not a member of the Users OU, then the User Principal Name, in the format of "user@domain", is required to log in.

## Assigning the group (role) to the user

To assign the user to a group in Active Directory, refer to [www.microsoft.com](http://www.microsoft.com) or Microsoft documentation. If you have a user-defined group, use the `ldapCfg --maprole` command to map LDAP server permissions to one of the default roles available on a switch.

Alternatively, update the `memberOf` field with the login permissions (root, admin, switchAdmin, user, and so on) that the user must use to log in to the switch.

## Adding a Virtual Fabric list

1. From the Windows Start menu, select **Programs > Administrative Tools > ADSI.msc**.

ADSI is a Microsoft Windows Resource Utility. This utility must be installed to proceed with the rest of the setup. For Windows 2003, this utility comes with Service Pack 1 or you can download this utility from the Microsoft website.

2. Go to **CN=Users**.

3. Select **Properties**. Click the **Attribute Editor** tab.
4. Double-click the **adminDescription** attribute.

The String Attribute Editor dialog box displays.

#### NOTE

The attribute can be added to user objects only.

5. Enter the values of the logical fabrics separated by a semi-colon ( ; ) into the **Value** field.

Example for adding Virtual Fabrics:

```
HomeLF=10;LFRoleList=admin:128,10;ChassisRole=admin
```

In this example, the logical switch that would be logged in to by default is 10. If 10 is not available, then the lowest FID available will be chosen. You would have permission to enter logical switch 128 and 10 in an admin role and you would also have the chassis role permission of admin.

#### NOTE

You can perform batch operations using the `ldifde.exe` utility. For more information on importing and exporting schemas, refer to your Microsoft documentation or visit [www.microsoft.com](http://www.microsoft.com).

## Adding attributes to the Active Directory schema

To create a group in Active Directory, refer to [www.microsoft.com](http://www.microsoft.com) or Microsoft documentation. You must:

- Add a new attribute **brcdAdvfData** as Unicode String.
- Add **brcdAdvfData** to the person's properties.

## LDAP configuration and OpenLDAP

Fabric OS provides user authentication and authorization by means of OpenLDAP or the Microsoft Active Directory service in conjunction with LDAP on the switch. This section discusses authentication and authorization using OpenLDAP. For information about authentication and authorization using Microsoft Active Directory, refer to [LDAP configuration and Microsoft Active Directory](#) on page 174.

Two operational modes exist in LDAP authentication: FIPS mode and non-FIPS mode. This section discusses LDAP authentication in non-FIPS mode. For information on LDAP in FIPS mode, refer to [Configuring Security Policies](#) on page 215. When using OpenLDAP in non-FIPS mode, you must use the Common-Name for OpenLDAP authentication. User-Principal-Name is not supported in OpenLDAP. OpenLDAP 2.4.23 is supported.

When a user is authenticated, the role of the user is obtained from the **memberOf** attribute, which determines group membership. This feature is supported in OpenLDAP through the **memberOf** overlay. You must use this overlay on the OpenLDAP server to assign membership information.

For OpenLDAP servers, you can use the `ldapCfg --maprole` command to map LDAP server permissions to one of the default roles available on a switch. For more information on RBAC roles, see [Role-Based Access Control](#) on page 145.

## OpenLDAP server configuration overview

For complete details about how to install and configure an OpenLDAP server, refer to the OpenLDAP user documentation at <http://www.openldap.org/doc/>. A few key steps for the Brocade environment are outlined here.

1. If your OpenLDAP server needs to be verified by the LDAP client (that is, the Brocade switch), then you must install a Certificate Authority (CA) certificate on the OpenLDAP server.

Follow OpenLDAP instructions for generating and installing CA certificates on an OpenLDAP server.

2. Enable group membership through the memberOf mechanism by including the memberOf overlay in the slapd.conf file.
3. Create entries (users) in the OpenLDAP Directory.
4. Assign users to groups by using the **member** attribute.
5. Use the `ldapCfg --maprole ldap_role_name switch_role` command to map an LDAP server role to one of the default roles available on the switch.
6. Add the user's Virtual Fabrics to the user entry.
  - a) Add the **brcdAdvfData** attribute to the existing OpenLDAP schema,
  - b) Add the **brcdAdvfData** attribute to the user entry in the LDAP directory with a value that identifies the Virtual Fabrics with which to associate the user.

## Enabling group membership

Group membership in OpenLDAP is specified by an overlay called memberOf. Overlays are helpful in customizing the back-end behavior without requiring changes to the back-end code. The memberOf overlay updates the **memberOf** attribute whenever changes occur to the membership attribute of entries of the groupOfNames objectClass. To include this overlay, add "overlay memberof" to the slapd.conf file, as shown in the following example.

```
overlay memberof
Example file:
include /usr/local/etc/openldap/schema/core.schema
include /usr/local/etc/openldap/schema/cosine.schema
include /usr/local/etc/openldap/schema/local.schema
#####
TLSCACertificateFile /root/sachin/ldapcert/cacert.pem
TLSCertificateFile /root/sachin/ldapcert/serverCert.pem
TLSCertificateKeyFile /root/sachin/ldapcert/serverKey.pem
TLSVerifyClient never
pidfile /usr/local/var/run/slapd.pid
argsfile /usr/local/var/run/slapd.args
database bdb
suffix "dc=mybrocade,dc=com"
rootdn "cn=Manager,dc=mybrocade,dc=com"
rootpw {SSHA}HL8uT5hPaWyIdcP6yAheMT8n0GoWubr3
# The database directory MUST exist prior to running slapd AND
# should only be accessible by the slapd and slap tools.
# Mode 700 recommended.
directory /usr/local/var/openldap-data
# Indices to maintain
index objectClass eq
overlay memberof
```

## Adding entries to the directory

To add entries in the OpenLDAP directory, perform the following steps.

1. Using a text editor of your choice, create a .ldif file and enter the information for the entry.

The following example defines an organizational role for the Directory Manager in a .ldif file for an organization with the domain name mybrocade.com.

```
# Organization for mybrocade Corporation
dn: dc=mybrocade,dc=com
objectClass: dcObject
objectClass: organization
dc: mybrocade
o: Mybrocade Corporation
description: Mybrocade Corporation
#####
# Organizational Role for Directory Manager
```

```
dn: cn=Manager,dc=mybrocade,dc=com
objectClass: organizationalRole
cn: Manager
description: Directory Manager
```

2. Enter the **ldapadd** command to add the contents of the .ldif file to the Directory, where test.ldif is the file you created in step 1.

```
switch:admin> ldapadd -D cn=Manager,dc=mybrocade,dc=com -x -w secret -f test.ldif
```

## Assigning a user to a group

Before you can assign a user to a group, the `memberOf` overlay must be added to the `slapd.conf` file. Refer to [Enabling group membership](#) on page 177 for details.

1. In a .ldif file, create a "groupOfNames" objectClass entry with the name of the group, for example, "admin," to create a group.
2. Set a "member" attribute for the group instance to identify the member, as in this example:  
"cn=Sachin,cn=Users,dc=mybrocade,dc=com"

Automatically, the "memberOf" attribute of the entry Sachin will have the value "cn=admin,ou=groups,dc=mybrocade,dc=com", which assigns Sachin to the admin group.

3. Enter the **ldapadd** command.

For example, the .ldif file might contain information similar to the following:

```
#Groups in organization
dn: ou=groups,dc=mybrocade,dc=com
objectclass:organizationalunit
ou: groups
description: generic groups branch
dn: cn=admin,ou=groups,dc=mybrocade,dc=com
objectclass: groupofnames
cn: admin
description: Members having admin permission
#Add members for admin group
member: cn=sachin,cn=Users,dc=mybrocade,dc=com
```

## Assigning the LDAP role to a switch role

Use the **ldapCfg --maprole** command to map LDAP server permissions to one of the default roles available on a switch.

## Modifying an entry

To modify a directory entry, perform the following steps.

1. Create a .ldif file containing the information to be modified.
2. Enter the **ldapmodify** command with the **-f** option specifying the .ldif file you created in step 1.

to delete a user attribute

## Adding a Virtual Fabric list

Use the **brcdAdVfData** attribute to map a role to a Virtual Fabric. To perform this operation, you must modify the schema to include the definition of the **brcdAdVfData** attribute and the definition of a user class that can use this attribute. You can then add this attribute to user entries in the LDAP directory.

1. In a schema file, assign the **brcdAdVfData** attribute to a user class.

The following sample schema file defines a new objectClass named "user" with optional attributes "brcdAdvfData" and "description".

```
#New attr brcdAdvfData
attributetype ( 1.3.6.1.4.1.8412.100
  NAME ( 'brcdAdvfData' )
  DESC 'Brocade specific data for LDAP authentication'
  EQUALITY caseIgnoreIA5Match
  SUBSTR caseIgnoreIA5SubstringsMatch
  SYNTAX 1.3.6.1.4.1.1466.115.121.1.26{256} )
objectclass ( 1.3.6.1.4.1.8412.110 NAME 'user'
  DESC 'Brocade switch specific person'
  SUP top AUXILIARY
  MAY ( brcdAdvfData $ description ) )
```

2. Include the schema file in the slapd.conf file.

The following example slapd.conf line assumes that local.schema contains the attribute definition provided in [Adding a Virtual Fabric list](#).

```
include /usr/local/etc/openldap/schema/local.schema
```

3. Include the **brcdAdvfData** attribute in a user entry in the LDAP directory.

- If you are using Virtual Fabrics, enter the value of the logical fabrics to which the user has access. Up to three value fields can be specified, separated by an semicolons (;):
  - The HomeLF field specifies the user's home Logical Fabric.
  - The LFRole list field specifies the additional Logical Fabrics to which the user has access and the user's access permissions for those Logical Fabrics. Logical Fabric numbers are separated by commas (,). A hyphen (-) indicates a range.
  - The ChassisRole field designates the permissions that apply to the ChassisRole subset of commands.

#### Example for adding Virtual Fabrics

In the following example, the logical switch that would be logged in to by default is 10. If 10 is not available, then the lowest FID available will be chosen. The user is given permission to enter logical switches 1 through 128 in an admin role and is also given the chassis role permission of admin.

```
brcdAdvfData: HomeLF=10;LFRoleList=admin:1-128;ChassisRole=admin
```

The following fragment from a file named test4.ldif provides an entry for a user with Virtual Fabric access roles.

```
# Organizational Role for Users
dn: cn=Users,dc=mybrocade,dc=com
objectClass: organizationalRole
cn: Users
description: User
# User entries
dn: cn=Sachin,cn=Users,dc=mybrocade,dc=com
objectClass: user
objectClass: person
objectClass: uidObject
cn: Sachin
sn: Mishra
description: First user
brcdAdvfData: HomeLF=30;LFRoleList=admin:1-128;ChassisRole=admin
userPassword: pass
uid: mishras@mybrocade.com
```

The following command adds the user to the LDAP directory.

```
switch:admin> ldapadd -D cn=Sachin,dc=mybrocade,dc=com -x -w secret -f test4.ldif
```

## TACACS+ service

Fabric OS can authenticate users with a remote server using the Terminal Access Controller Access-Control System Plus (TACACS+) protocol. TACACS+ is a protocol used in AAA server environments consisting of a centralized authentication server and multiple Network Access Servers or clients. Once configured to use TACACS+, a Brocade switch becomes a Network Access Server (NAS).

The following authentication protocols are supported by the TACACS+ server for user authentication:

- Password Authentication Protocol (PAP)
- Challenge Handshake Authentication Protocol (CHAP)

TACACS+ is not a FIPS-supported protocol, so you cannot configure TACACS+ in FIPS mode. To enable FIPS, any TACACS+ configuration must be removed.

The TACACS+ server can be a Microsoft Windows server or a Linux server. For Linux servers, use TACACS+ 4.0.4 or later from Cisco. For Microsoft Windows servers, use any TACACS+ freeware that uses TACACS+ protocol v1.78 or later.

## TACACS+ configuration overview

Configuration is required on both the TACACS+ server and the Brocade switch. On the TACACS+ server, you should assign a role for each user and, provide lists of Virtual Fabrics to which the user should have access. For details, refer to [The tac\\_plus.cfg file](#) on page 180.

On the Brocade switch, use the **aaaConfig** command to configure the switch to use TACACS+ for authentication. The **aaaConfig** command also allows you to specify up to five TACACS+ servers. When a list of servers is configured, failover from one server to another server happens only if a TACACS+ server fails to respond. It does not happen when user authentication fails.

Failover to another TACACS+ server is achieved by means of a timeout. You can configure a timeout value for each TACACS+ server, so that the next server can be used in case the first server is unreachable. The default timeout value is 5 seconds.

Retry, the number of attempts to authenticate with a TACACS+ server, is also allowed. The default value is 5 attempts. If authentication is rejected or times out, Fabric OS will try again. The retry value can also be customized for each user.

Refer to [Remote authentication configuration on the switch](#) on page 182 for details about configuring the Brocade switch for authenticating users with a TACACS+ server.

## Configuring the TACACS+ server on Linux

Fabric OS software supports TACACS+ authentication on a Linux server running the Open Source TACACS+ LINUX package v4.0.4 from Cisco. To install and configure this software, perform the following steps.

1. Download the TACACS+ software from <http://www.cisco.com> and install it.
2. Configure the TACACS+ server by editing the `tac_plus.cfg` file.  
Refer to [The tac\\_plus.cfg file](#) on page 180 for details.
3. Run the **tac\_plus** daemon to start and enable the TACACS+ service on the server.

```
switch:admin> tac_plus -d 16 /usr/local/etc/mavis/sample/tac_plus.cfg
```

## The tac\_plus.cfg file

The TACACS+ server is configured in the `tac_plus.cfg` file. Open the file by using the editor of your choice and customize the file as needed.

You must add users into this file and provide some attributes specific to the Brocade implementation. [Table 28](#) lists and defines attributes specific to Brocade.



TABLE 28 Brocade custom TACACS+ attributes

Attribute	Purpose
brcd-role	Role assigned to the user account
brcd-AV-Pair1	The Virtual Fabric member list, and chassis role
brcd-AV-Pair2	The Virtual Fabric member list, and chassis role
brcd-passwd-expiryDate	The date on which the password expires
brcd-passwd-warnPeriod	The time before expiration for the user to receive a warning message

### Adding a user and assigning a role

When adding a user to the `tac_plus.cfg` file, you should at least provide the **brcd-role** attribute. The value assigned to this attribute should match a role defined for the switch. When a login is authenticated, the role specified by the **brcd-role** attribute represents the permissions granted to the account. If no role is specified, or if the specified role does not exist on the switch, the account is granted user role permissions only.

Refer to [Role-Based Access Control](#) on page 145 for details about roles.

The following fragment from a `tac_plus.cfg` file adds a user named `fosuser1` and assigns the `securityAdmin` role to the account.

```
user = fosuser1 {
    chap = cleartext "my$chap$pswrd"
    pap = cleartext "pap-password"
    service = exec {
        brcd-role = securityAdmin;
    }
}
```

### Configuring Virtual Fabric lists

If your network uses Virtual Fabrics, you should create Virtual Fabric lists for each user to identify the Virtual Fabrics to which the account has access.

Assign the following key-value pairs to the **brcd-AV--Pair1** and, optionally, **brcd-AV-Pair2** attributes to grant the account access to the Virtual Fabrics:

- **HomeLF** is the designated home Virtual Fabric for the account. The valid values are from 1 through 128 and chassis context. The first valid HomeLF key-value pair is accepted by the switch. Additional HomeLF key-value pairs are ignored.
- **LFRoleList** is a comma-separated list of Virtual Fabric ID numbers to which this account is a member, and specifies the role the account has on those Virtual Fabrics. Valid numbers range from 1 through 128. A - between two numbers specifies a range.

The following example sets the home Virtual Fabric for the `userVF` account to 30 and allows the account `admin` role access to Virtual Fabrics 1, 3, and 4 and `securityAdmin` access to Virtual Fabrics 5 and 6.

```
user = userVF {
    pap = clear "password"
    service = shell {
        set brcd-role = zoneAdmin
        set brcd-AV-Pair1 = "homeLF=30;LFRoleList=admin:1,3,4;securityAdmin:5,6"
        set brcd-AV-Pair2 = "chassisRole=admin"
    }
}
```

### Configuring the password expiration date

FabricOS allows you to configure a password expiration date for each user account and to configure a warning period for notifying the user that the account password is about to expire. To configure these values, set the following attributes:

- **brcd-passwd-expiryDate** sets the password expiration date in *mm/dd/yyyy* format.

- **brcd-passwd-warnPeriod** sets the warning period as a number of days.

The following example sets the password expiration date for the fosuser5 account. It also specifies that a warning be sent to the user 30 days before the password is due to expire.

```
user = fosuser5 {
  pap = clear "password"
  chap = clear "password"
  password = clear "password"
  service = shell {
    set brcd-role = securityAdmin
    set brcd-passwd-expiryDate = 03/21/2014;
    set brcd-passwd-warnPeriod = 30;
  }
}
```

## Configuring a Windows TACACS+ server

Fabric OS is compatible with any TACACS+ freeware for Microsoft Windows that uses TACACS+ protocol version v1.78. Refer to the vendor documentation for configuration details.

## Remote authentication configuration on the switch

At least one RADIUS, LDAP, or TACACS+ server must be configured before you can enable a remote authentication service. You can configure the remote authentication service even if it is disabled on the switch. You can configure up to five RADIUS, LDAP, or TACACS+ servers. You must be logged in as admin or switchAdmin to configure the RADIUS service.

### NOTE

On DCX 8510 Backbones and X6 Directors, the switch sends its RADIUS, LDAP, or TACACS+ request using the IP address of the active CP. When adding clients, add both the active and standby CP IP addresses so that users can still log in to the switch in the event of a failover.

RADIUS, LDAP, or TACACS+ configuration is chassis-based configuration data. On platforms containing multiple switch instances, the configuration applies to all instances. The configuration is persistent across reboots and firmware downloads. On a chassis-based system, the command must replicate the configuration to the standby CP.

Multiple login sessions can invoke the **aaaConfig** command simultaneously. The last session that applies the change is the one whose configuration is in effect. This configuration is persistent after an HA failover.

The authentication servers are contacted in the order they are listed, starting from the top of the list and moving to the bottom.

## Adding an authentication server to the switch configuration

1. Connect to the switch and log in using an account with admin permissions.
2. Enter the **aaaConfig --add** command.

At least one authentication server must be configured before you can enable the RADIUS, LDAP, or TACACS+ service.

If no RADIUS, LDAP, or TACACS+ configuration exists, turning on the authentication mode triggers an error message. When the command succeeds, the event log indicates that the configuration is enabled or disabled.

## Enabling and disabling remote authentication

1. Connect to the switch and log in using an account with admin permissions.
2. Enter the **aaaConfig --authspec** command to enable or disable RADIUS, LDAP, or TACACS+.

You must specify the type of service as one of RADIUS, LDAP, or TACACS+. Local is used for local authentication if the user authentication fails on the authentication server.

Example for enabling RADIUS

```
switch:admin> aaaconfig --authspec "radius;local" -backup
```

Example for enabling LDAP

```
switch:admin> aaaconfig --authspec "ldap;local" -backup
```

Example for enabling TACACS+

```
switch:admin> aaaconfig --authspec "tacacs+;local" -backup
```

### Deleting an authentication server from the configuration

1. Connect to the switch and log in using an account with admin permissions.
2. Enter the **aaaConfig --remove** command.

When the command succeeds, the event log indicates that the server is removed.

### Changing an authentication server configuration

1. Connect to the switch and log in using an account with admin permissions.
2. Enter the **aaaConfig --change** command.

### Changing the order in which authentication servers are contacted for service

1. Connect to the switch and log in using an account with admin permissions.
2. Enter the **aaaConfig --move** command.

When the command succeeds, the event log indicates that a server configuration is changed.

### Displaying the current authentication configuration

1. Connect to the switch and log in using an account with admin permissions.
2. Enter the **aaaConfig --show** command.

If a configuration exists, its parameters are displayed. If the RADIUS, LDAP, or TACACS+ service is not configured, only the parameter heading line is displayed. Parameters include:

Position	The order in which servers are contacted to provide service.
Server	The server names or IPv4 or IPv6 addresses. IPv6 is not supported when using PEAP authentication.
Port	The server ports.
Secret	The shared secrets.
Timeouts	The length of time servers have to respond before the next server is contacted.
Authentication	The type of authentication being used on servers.

## Configuring local authentication as backup

It is useful to enable local authentication, so that the switch can take over authentication locally if the RADIUS or LDAP servers fail to respond because of power outage or network problems.

1. Connect to the switch and log in using an account with admin permissions.
2. Enter the **aaaConfig --authspec** command to enable or disable RADIUS, LDAP, or TACACS+ with local authentication as a backup authentication mechanism.

You must specify the type of service as one of RADIUS, LDAP, or TACACS+. Local is used for local authentication if the user authentication fails on the authentication server.

### Example for RADIUS

Example of enabling local authentication as a backup for RADIUS.

```
switch:admin> aaaconfig --authspec "radius;local" -backup
```

### Example for LDAP

```
switch:admin> aaaconfig --authspec "ldap;local" -backup
```

### Example for TACACS+

```
switch:admin> aaaconfig --authspec "tacacs+;local" -backup
```

For details about the **aaaConfig** command refer to [Command options](#) on page 162.

When local authentication is enabled and the authentication servers fail to respond, you can log in to the default switch accounts (admin and user) or any user-defined account. You must know the passwords of these accounts.

When the **aaaConfig** command succeeds, the event log indicates that local database authentication is disabled or enabled.

# Configuring Protocols

- Security protocols.....185
- Secure Copy.....186
- Secure Shell protocol.....187
- Configuring the ciphers, KEX, and MAC algorithms.....194
- Secure Sockets Layer protocol .....195
- Simple Network Management Protocol.....200
- Telnet protocol.....211
- Listener applications.....213
- Ports and applications used by switches.....213

## Security protocols

Security protocols provide endpoint authentication and communications privacy using cryptography.

Typically, you are authenticated to the switch while the switch remains unauthenticated to you. This means that you can be sure with what you are communicating. The next level of security, in which both ends of the conversation are sure with whom they are communicating, is known as two-factor authentication. Two-factor authentication requires public key infrastructure (PKI) deployment to clients.

Fabric OS supports the secure protocols shown in the following table.

**TABLE 29** Secure protocol support

Protocol	Description
CHAP	Challenge Handshake Authentication Protocol (CHAP) uses shared secrets to authenticate switches.
HTTPS	HTTPS is a Uniform Resource Identifier scheme used to indicate a secure HTTP connection. Web Tools supports the use of Hypertext Transfer Protocol over SSL (HTTPS).
IPsec	Internet Protocol Security (IPsec) is a framework of open standards for providing confidentiality, authentication and integrity for IP data transmitted over untrusted links or networks.
LDAP	Lightweight Directory Access Protocol with TLS uses a certificate authority (CA). By default, LDAP traffic is transmitted unsecured. With the import of signed certificates, you can make LDAP traffic confidential and secure by using Secure Sockets Layer (SSL) / Transport Layer Security (TLS) technology in conjunction with LDAP.
SCP	Secure Copy (SCP) is a means of securely transferring computer files between a local and a remote host or between two remote hosts, using the Secure Shell (SSH) protocol. Configuration upload and download support the use of SCP.
Secure Syslog	Secure syslog requires importing syslog CA certificates using the <b>secCerUtil</b> command.
SFTP	Secure File Transfer Protocol (SFTP) is a network protocol for securely transferring files on a network. Configuration upload and download support the use of SFTP.
SNMP	Simple Network Management Protocol (SNMP) is used in network management systems to monitor network-attached devices for conditions that warrant administrative attention. Supports SNMPv1 and v3.
SSH	Secure Shell (SSH) is a network protocol that allows data to be exchanged over a secure channel between two computers. Encryption provides confidentiality and integrity of data. SSH uses public-key cryptography to

**TABLE 29** Secure protocol support (continued)

Protocol	Description
	authenticate the remote computer and allow the remote computer to authenticate the user, if necessary.
SSL	Fabric OS uses Secure Socket Layer (SSL) to support HTTPS. A certificate must be generated and installed on each switch to enable SSL. Supports SSLv3, 128-bit encryption by default. Also supports TLSv1.0, TLSv1.1, and TLSv1.2.

**NOTE**

Challenge Response Authentication (CRA) is supported in SCP and SSH sessions.

[Table 30](#) describes additional software or certificates that you must obtain to deploy secure protocols.

**TABLE 30** Items needed to deploy secure protocols

Protocol	Host side	Switch side
SSHv2	Secure shell client	None
HTTPS	No requirement on host side except a browser that supports HTTPS	Switch IP certificate for SSL
SCP	SSH daemon, SCP server	None
SNMPv3	None	None

The security protocols are designed with the four main use cases described in [Table 31](#).

**TABLE 31** Main security scenarios

Fabric	Management interfaces	Comments
Nonsecure	Nonsecure	No special setup is needed to use Telnet or HTTP.
Nonsecure	Secure	Secure protocols may be used. An SSL switch certificate must be installed if HTTPS is used.
Secure	Secure	Switches running earlier Fabric OS versions can be part of the secure fabric, but they do not support secure management.  Secure management protocols must be configured for each participating switch. Nonsecure protocols may be disabled on nonparticipating switches.  If SSL is used, then certificates must be installed. For more information on installing certificates, refer to <a href="#">Installing a switch certificate</a> on page 198.
Secure	Nonsecure	You must use SSH because Telnet is not allowed with some features.

## Secure Copy

The Secure Copy protocol (SCP) runs on port 22. It encrypts data during transfer, thereby avoiding packet sniffers that attempt to extract useful information during data transfer. SCP relies on SSH to provide authentication and security.

## Setting up SCP for configuration uploads and downloads

Use the following procedure to configure SCP for configuration uploads and downloads.

1. Connect to the switch and log in using an account with admin permissions.
2. Enter one of the following commands:
  - If Virtual Fabrics is enabled, enter the **configurechassis** command.
  - If Virtual Fabrics is not enabled, enter the **configure** command.
3. Enter **y** at the **cfgload attributes** prompt.
4. Enter **y** at the **Enforce secure configUpload/Download** prompt.

Example of setting up SCP for configUpload/download

```
switch:admin# configure

Not all options will be available on an enabled switch.
To disable the switch, use the "switchDisable" command.
Configure...
System services (yes, y, no, n): [no] n
ssl attributes (yes, y, no, n): [no] n
http attributes (yes, y, no, n): [no] n
snmp attributes (yes, y, no, n): [no] n
rpcd attributes (yes, y, no, n): [no] n
cfgload attributes (yes, y, no, n): [no] y
Enforce secure config Upload/Download (yes, y, no, n): [no]# y
Enforce signature validation for firmware (yes, y, no, n): [no]#
```

## Secure Shell protocol

To ensure security, Fabric OS supports Secure Shell (SSH) encrypted sessions. SSH encrypts all messages, including the client transmission of the password during login.

The SSH package contains a daemon (sshd), which runs on the switch. The daemon supports a wide variety of encryption algorithms, such as Digital Encryption Standard (DES) and Advanced Encryption Standard (AES).

### NOTE

To maintain a secure network, you should avoid using Telnet or any other unprotected application when you are working on the switch.

Commands that require a secure login channel must originate from an SSH session. If you start an SSH session, and then use the **login** command to start a nested SSH session, commands that require a secure channel will be rejected.

Fabric OS supports OpenSSH version 6.2p2 and OpenSSL version 1.0.1e with the heartbeat feature disabled .

If you set up a message of the day (MOTD), the MOTD displays either before or after the login prompt, depending on the SSH client implementation. Fabric OS does not control when the message displays.

## SSH public key authentication

OpenSSH public key authentication provides password-less logins, known as SSH authentication, that uses public and private key pairs for incoming and outgoing authentication.

This feature allows only one *allowed-user* to be configured to utilize outgoing OpenSSH public key authentication. Any admin user can perform incoming Open SSH public key authentication.

Using OpenSSH RSA, DSA, and ECDSA, the authentication protocols are based on a pair of specially generated cryptographic keys, called the private key and the public key. The advantage of using these key-based authentication systems is that in many cases, it is possible to establish secure connections without having to depend on passwords for security. RSA and ECDSA asynchronous algorithms are FIPS-compliant.

Incoming authentication is used when the remote host needs to authenticate to the switch. Outgoing authentication is used when the switch needs to authenticate to a server or remote host, such as when running the **configUpload** or **configDownload** commands, or performing firmware download. Both password and public key authentication can coexist on the switch.

#### NOTE

SSH is supported only with local user accounts.

### Allowed-user

For outgoing authentication, the default admin user must set up the allowed-user with admin permissions. By default, the admin is the configured allowed-user. While creating the key pair, the configured allowed-user can choose a passphrase with which the private key is encrypted. Then the passphrase must always be entered when authenticating to the switch. The allowed-user must have admin permissions to perform OpenSSH public key authentication, import and export keys, generate a key pair for an outgoing connection, and delete public and private keys.

#### NOTE

There are no special privileges required for the incoming allowed user.

### Configuring incoming SSH authentication

1. Log in to your remote host.
2. Generate a key pair for host-to-switch (incoming) authentication by verifying that SSH v2 is installed and working (refer to your host's documentation as necessary) by entering the following command:

```
ssh-keygen -t rsa
```

The following example generates RSA/DSA key pair.

```
anyuser@mymachine: ssh-keygen -t rsa
Generating public/private rsa key pair.
Enter file in which to save the key (/users/anyuser/.ssh/id_rsa
):
Enter passphrase (empty for no passphrase):
Enter same passphrase again:
Your identification has been saved in /users/anyuser/.ssh/id_rsa.
Your public key has been saved in /users/anyuser/.ssh/id_rsa.pub.
The key fingerprint is:
32:9f:ae:b6:7f:7e:56:e4:b5:7a:21:f0:95:42:5c:d1 anyuser@mymachine
```

3. Import the public key to the switch by logging in to the switch as any user with the admin role and entering the **sshUtil importpubkey** command to import the key.

The following example adds the public key to the switch.

```
switch:anyuser> sshutil importpubkey
Enter user name for whom key is imported: aswitchuser
Enter IP address:192.168.38.244
Enter remote directory:~auser/.ssh
Enter public key name(must have .pub suffix):id_rsa.pub
Enter login name:auser
Password:
Public key is imported successfully.
```

4. Test the setup by logging in to the switch from a remote device, or by running a command remotely using SSH.



## Configuring outgoing SSH authentication

After the `allowed-user` is configured, the remaining setup steps must be completed by the `allowed-user`.

Use the following procedure to configure outgoing SSH authentication.

1. Log in to the switch as the default admin.
2. Change the `allowed-user`'s permissions to admin, if applicable.

```
switch:admin> userconfig --change username -r admin
```

The `username` variable is the name of the user who can perform SSH public key authentication, and who can import, export, and delete keys.

3. Set up the `allowed-user` by typing the following command:

```
switch:admin> sshutil allowuser username
```

The `username` variable is the name of the user who can perform SSH public key authentication, and who can import, export, and delete keys.

4. Generate a key pair for switch-to-host (outgoing) authentication by logging in to the switch as the `allowed-user` and entering the `sshUtil genkey` command.

You may enter a passphrase for additional security.

Example of generating a key pair on the switch

```
switch:alloweduser> sshutil genkey
Enter passphrase (empty for no passphrase):
Enter same passphrase again:
Key pair generated successfully.
```

5. Export the public key to the host by logging in to the switch as the `allowed-user` and entering the `sshUtil exportpubkey` command to export the key.

Example of exporting a public key from the switch

```
switch:alloweduser> sshutil exportpubkey

Enter IP address:192.168.38.244

Enter remote directory:~auser/.ssh

Enter login name:auser

Password:
public key out_going.pub is exported successfully.
```

6. Append the public key to a remote host by logging in to the remote host, locating the directory where authorized keys are stored, and appending the public key to the file.

You may need to refer to the host's documentation to locate where the authorized keys are stored.

7. Test the setup by using a command that uses SCP and authentication, such as `firmwareDownload` or `configUpload`.

## Deleting public keys on the switch

Use the following procedure to delete public keys from the switch.

1. Connect to the switch and log in using an account with admin permissions.
2. Use the `sshUtil delpubkeys` command to delete public keys.

You will be prompted to enter the name of the user whose the public keys you want to delete. Enter **all** to delete public keys for all users.

For more information on IP filter policies, refer to [Configuring Security Policies](#) on page 215.

## Deleting private keys on the switch

Use the following procedure to delete private keys from the switch.

1. Log in to the switch as the allowed-user.
2. Use the **sshUtil delprivkey** command to delete the private key.

For more information on IP filter policies, refer to [Configuring Security Policies](#) on page 215.

## Generate and install hostkey on a switch

You can generate, install, display, delete SSH hostkeys on a switch.

1. Log in to the switch as the allowed-user.
2. Run the **sshUtil genHostKey -[rsa|dsa|ecdsa ]** command to generate and install the SSH hostkey.
3. Run the **sshUtil showHostKey** command to display current SSH hostkeys installed on the switch.
4. Run the **sshUtil deleteHostKey** command to delete the selected SSH hostkeys on the switch.

## Managing SecCryptoCfg templates

SecCryptoCfg templates provide granularity in choosing, verifying, and confirming the switch cipher configurations as per the requirement, for example Certificate Authorities. Templates can be used to configure the ciphers based on the requirement. Currently, templates are supported for TLS, SSH and FIPS configuration. You can use the secCryptoCfg CLI to configure ciphers and FIPS mode through a template file. Templates consists of key value pairs for configuring ciphers such as for RADIUS, LDAP, HTTPS, SSH ciphers, SSH key exchange algorithms, and SSH MAC.

The following default templates are available and supported:

- Default Configuration (default\_generic)
- Secured configuration (default\_strong)
- FIPS configuration (default\_fips)
- CC configuration (default\_cc)

A default template can be specific to the requirements of a certification or based on the definition of security configurations for various security levels. For example, high security configuration template can enforce high security strengths that are not FIPS approved too. You cannot overwrite the default configurations but can upload the configurations, edit, and then download it with a different name. You can create a new template similar to default templates, download, and apply. Only a maximum of eight templates including the default templates are supported.

## Format and rule of the template

- The templates must be organized into the following groups and options:

Group	Option
SSH	Kex, Mac, Enc
HTTPS	Ciphers
AAA	RAD_Ciphers, LDAP_Ciphers

Group	Option
FIPS	Enable, Zeroize, selfTests

- The version must be specified to identify the version type.
- If an option is mentioned multiple times, the last value is considered.
- Lines starting with /\* are considered to be comments and must be terminated with \*/
- Configuration upload/download does not include these template files. You must use the commands to import, export, apply, and delete templates.

Use the following commands to manage the template files:

1. Run the **secCryptoCfg -apply** command to set a template file.

```
switch:admin> seccryptocfg -apply <template filename>
```

2. Run the **secCryptoCfg -import** command to import a template file.

```
switch:admin> seccryptocfg -import <template filename> [-server <ipaddr> -name <user> -proto <ftp|
scp> -file <remotefilename>]
<Interactive Prompt comes up to provide server details>
```

3. Run the **secCryptoCfg -export** command to export a template file.

```
switch:admin> seccryptocfg -export <template filename> [-server <ipaddr> -name <user> -mode <ftp|
scp>]
```

4. Run the **secCryptoCfg -verify** command to verify the running configuration against a required configuration specified in the template file.

```
switch:admin> seccryptocfg -verify <Template name>
```

5. Run the **secCryptoCfg -show** command to displays the existing ciphers, Kex, and Mac, or configuration contents in the template file if you provide a template name.

```
switch:admin> seccryptocfg -show <template name>
switch:admin> seccryptocfg --show
```

6. Run the **secCryptoCfg -delete** command to delete a template file.
7. Run the **secCryptoCfg --ltemplates** command to list all the template files.

## Default secCryptoCfg templates

The following default secCryptoCfg templates are available and supported:

### Default\_generic

```

/*****
* Brocade - Generic Template for Security Crypto Configuration
*
* Desc:
*
* Default values for security crypto configurations for operation in
* generic mode
*
*****/

[Ver] 0.1

/*
```

```

* Group : SSH
* Rules : Comma Separated
* Example : aes128-ctr,aes192-ctr -> Note, no space before and after comma.
* Valid options: Kex, Mac, Enc
*/
[SSH]
Enc:aes128-ctr,aes192-ctr,aes256-ctr,aes128-cbc,3des-cbc,aes192-cbc,aes256-cbc
Kex:ecdh-sha2-nistp256,ecdh-sha2-nistp384,ecdh-sha2-nistp521,diffie-hellman-group-exchange-sha256,diffie-
hellman-group-exchange-sha1,diffie-hellman-group14-sha1,diffie-hellman-group1-sha1
Mac:hmac-md5,hmac-sha1,hmac-sha2-256,hmac-sha2-512

/*
* Group : AAA
* Rules : Textual openssl cipherlist (colon,comma and space separated)
* Example: ALL:-MD5:!PSK
* Valid options: RAD_Ciphers, LDAP_Ciphers
*/
[AAA]
RAD_Ciphers:!ECDH:!DH:HIGH:-MD5:!CAMELLIA:!SRP:!PSK:!AESGCM
LDAP_Ciphers:!ECDH:!DH:HIGH:-MD5:!CAMELLIA:!SRP:!PSK:!AESGCM

/*
* Group : HTTPS
* Rules : Textual openssl cipherlist (colon,comma and space separated)
* Example: ALL:-MD5:!PSK
* Valid options: Ciphers
*/
[HTTPS]
Ciphers:!ECDH:!DH:HIGH:-MD5:!CAMELLIA:!SRP:!PSK:!AESGCM

```

### Default\_strong

Strong configuration consist of TLSv1.2 and SHA above 256.

```

/*****
* Brocade - Template for High Security Crypto Configuration
*
* Desc:
*
* Default values for security crypto configurations for high security
*
*****/

[Ver] 0.1

/*
* Group : SSH
* Rules : Comma Separated
* Example : aes128-ctr,aes192-ctr -> Note, no space before and after comma.
* Valid options: Kex, Mac, Enc
*/
[SSH]
Enc:aes128-ctr,aes192-ctr,aes256-ctr,aes128-cbc,3des-cbc,aes192-cbc,aes256-cbc
Kex:ecdh-sha2-nistp256,ecdh-sha2-nistp384,ecdh-sha2-nistp521,diffie-hellman-group-exchange-sha256
Mac:hmac-sha2-256,hmac-sha2-512

/*
* Group : AAA
* Rules : Textual openssl cipherlist (colon,comma and space separated)
* Example: ALL:-MD5:!PSK
* Valid options: RAD_Ciphers, LDAP_Ciphers
*/
[AAA]
RAD_Ciphers:!ECDH:!DH:HIGH:-MD5:!CAMELLIA:!SRP:!PSK:!AESGCM:!SSLv3
LDAP_Ciphers:!ECDH:!DH:HIGH:-MD5:!CAMELLIA:!SRP:!PSK:!AESGCM:!SSLv3

/*

```

```

* Group : HTTPS
* Rules : Textual openssl cipherlist (colon,comma and space separated)
* Example: ALL:-MD5:!PSK
* Valid options: Ciphers
*/
[HTTPS]
Ciphers:!ECDH:!DH:HIGH:-MD5:!CAMELLIA:!SRP:!PSK:!AESGCM:!SSLv3

```

## Default\_fips

FIPS template has the ciphers that are certified for Brocade products.

```

/*****
* Brocade - FIPS Template for Security Crypto Configuration
*
* Desc:
*
* Default values for security crypto configurations for FIPS compliance
*
*****/

[Ver] 0.1

/*
* Group : SSH
* Rules : Comma Separated
* Example : aes128-ctr,aes192-ctr -> Note, no space before and after comma.
* Valid options: Kex, Mac, Enc
*/
[SSH]
Enc:aes128-ctr,aes192-ctr,aes256-ctr,aes128-cbc,3des-cbc,aes192-cbc,aes256-cbc
Kex:ecdh-sha2-nistp256,ecdh-sha2-nistp384,ecdh-sha2-nistp521,diffie-hellman-group-exchange-sha256
Mac:hmac-sha1,hmac-sha2-256,hmac-sha2-512

/*
* Group : AAA
* Rules : Textual openssl cipherlist (colon,comma and space separated)
* Example: ALL:-MD5:!PSK
* Valid options: RAD_Ciphers, LDAP_Ciphers
*/
[AAA]
RAD_Ciphers:!ECDH:!DH:HIGH:-MD5:!CAMELLIA:!SRP:!PSK:!AESGCM
LDAP_Ciphers:!ECDH:!DH:HIGH:-MD5:!CAMELLIA:!SRP:!PSK:!AESGCM

/*
* Group : HTTPS
* Rules : Textual openssl cipherlist (colon,comma and space separated)
* Example: ALL:-MD5:!PSK
* Valid options: Ciphers
*/
[HTTPS]
Ciphers:!ECDH:!DH:HIGH:-MD5:!CAMELLIA:!SRP:!PSK:!AESGCM

/*
* Group : FIPS
* Rules : Applicable only to FIPS mode configuration. "yes" for configuration enabled and "no" for disabled
* Example: "yes" OR "no"
* Valid options: SelfTests, BootProm, Enable
*/
[FIPS]
SelfTests:yes
BootProm:no
Zeroize:yes
Enable:yes

```

## Default\_cc

```

/*****
* Brocade - Common Criteria (CC) Template for Security Crypto Configuration
*
* Desc:
*
* Default values for security crypto configurations for CC compliance
*
*****/

[Ver] 0.1

/*
* Group : SSH
* Rules : Comma Separated
* Example : aes128-ctr,aes192-ctr -> Note, no space before and after comma.
* Valid options: Kex, Mac, Enc
*/
[SSH]
Enc:aes128-cbc,aes256-cbc
Kex:diffie-hellman-group14-sha1,ecdh-sha2-nistp256,ecdh-sha2-nistp384,ecdh-sha2-nistp521
Mac:hmac-sha1,hmac-sha2-256,hmac-sha2-512

/*
* Group : AAA
* Rules : Textual openssl cipherlist (colon,comma and space separated)
* Example: ALL:-MD5:!PSK
* Valid options: RAD_Ciphers, LDAP_Ciphers
*/
[AAA]
RAD_Ciphers:!ECDH:!DH:HIGH:-MD5:!CAMELLIA:!SRP:!PSK:!AESGCM:!SSLv3
LDAP_Ciphers:!ECDH:!DH:HIGH:-MD5:!CAMELLIA:!SRP:!PSK:!AESGCM:!SSLv3

/*
* Group : HTTPS
* Rules : Textual openssl cipherlist (colon,comma and space separated)
* Example: ALL:-MD5:!PSK
* Valid options: Ciphers
*/
[HTTPS]
Ciphers:!ECDH:!DH:HIGH:-MD5:!CAMELLIA:!SRP:!PSK:!AESGCM:!3DES:!DES

```

## Configuring the ciphers, KEX, and MAC algorithms

Starting with Fabric OS 7.4.0, you can configure the ciphers, key exchange (KEX), and message authentication code (MAC) algorithms dictated by your security policies.

1. To configure the ciphers, KEX and MAC algorithm for SSH, use the **secCryptoCfg** command.

```
secCryptoCfg --replace -type SSH [-cipher cipher string|-kex value|-mac value] -force
```

The following example configures the ciphers, and KEX and MAC algorithms.

```
secCryptoCfg --replace -type SSH -cipher 3des-cbc,aes128-cbc,aes192-cbc -kex diffie-hellman-group-
exchange-sha1 -mac hmac-sha2-256
```

To enforce the default algorithm, use the following command.

```
secCryptoCfg --default -type SSH -force
```

2. To display the configured algorithm, use the following command.

```
secCryptoCfg --show
```

## Secure Sockets Layer protocol

Secure Sockets Layer (SSL) protocol provides secure access to a fabric through web-based management tools such as Web Tools. SSL support is a standard Fabric OS feature.

Switches configured for SSL grant access to management tools through Hypertext Transfer Protocol over SSL links (which begin with *https://*) instead of standard links (which begin with *http://*).

SSL uses public key infrastructure (PKI) encryption to protect data transferred over SSL connections. PKI is based on digital certificates obtained from an Internet Certificate Authority (CA) that acts as the trusted key agent.

Certificates are based on the switch IP address or fully qualified domain name (FQDN), depending on the issuing CA. If you change a switch IP address or FQDN after activating an associated certificate, you may have to obtain and install a new certificate. Check with the CA to verify this possibility, and plan these types of changes accordingly.

## Browser and Java support

Fabric OS supports the following web browsers for SSL connections:

- Internet Explorer v7.0 or later (Microsoft Windows)
- Mozilla Firefox v2.0 or later (Solaris and Red Hat Linux)

### NOTE

Review the release notes for the latest information and to verify if your platform and browser are supported.

In countries that allow the use of 128-bit encryption, you should use the latest version of your browser. For example, Internet Explorer 7.0 and later supports 128-bit encryption by default. You can display the encryption support (called "cipher strength") using the Internet Explorer **Help** > **About** menu option. If you are running an earlier version of Internet Explorer, you may be able to download an encryption patch from the Microsoft website at <http://www.microsoft.com>.

You should upgrade to the Java 1.6.0 plug-in on your management workstation. To find the Java version that is currently running, open the Java console and look at the first line of the window. For more details on levels of browser and Java support, refer to the *Web Tools Administrator's Guide*.

Enabling TLS 1.2 for the entire Web Tools session requires you to also enable TLS 1.2 in the Java Control Panel.

## SSL configuration overview

You configure SSL access for a switch by obtaining, installing, and activating digital certificates. Certificates are required on all switches that are to be accessed through SSL.

Also, you must install a certificate in the Java plug-in on the management workstation, and you may need to add a certificate to your web browser.

Configuring for SSL involves these main steps, which are shown in detail in the next sections.

1. Choose a certificate authority (CA).
2. Generate the following items on each switch:
  - a) A public and private key by using the **secCertUtil genkey** command.
  - b) A certificate signing request (CSR) by using the **secCertUtil gencsr** command.
3. Store the CSR on a file server by using the **secCertUtil export** command.
4. Obtain the certificates from the CA.

You can request a certificate from a CA through a web browser. After you request a certificate, the CA either sends certificate files by e-mail (public) or gives access to them on a remote host (private).

5. On each switch, install the certificate. Once the certificate is loaded on the switch, HTTPS starts automatically.
6. If necessary, install the root certificate to the browser on the management workstation.
7. Add the root certificate to the Java plug-in keystore on the management workstation.

## Certificate authorities

To ease maintenance and allow secure out-of-band communication between switches, consider using one certificate authority (CA) to sign all management certificates for a fabric. If you use different CAs, management services operate correctly, but the Web Tools **Fabric Events** button is unable to retrieve events for the entire fabric.

Each CA (for example, Verisign or GeoTrust) has slightly different requirements; for example, some generate certificates based on IP address, while others require an FQDN, and most require a 1024-bit public/private key pair while some may accept a 2048-bit key. Consider your fabric configuration, check CA websites for requirements, and gather all the information that the CA requires.

## Generating a public/private key pair

Use the following procedure to generate a public/private key pair.

### NOTE

You must perform this procedure on each switch.

1. Connect to the switch and log in using an account with admin permissions.
2. Enter the **secCertUtil genkey** command to generate a public/private key pair.

The system reports that this process will disable secure protocols, delete any existing CSR, and delete any existing certificates.

3. Respond to the prompts to continue and select the key size.

The following example generates a key pair

```
Continue (yes, y, no, n): [no] y
Select key size [1024 or 2048]: 1024
Generating new rsa public/private key pair
Done.
```

## Generating and storing a Certificate Signing Request

After generating a public/private key pair, you must generate and store a certificate signing request (CSR).

1. Connect to the switch and log in using an account with admin permissions.
2. Enter **secCertUtil gencsr**.
3. Enter the requested information.

The following example generates a CSR.

```
Country Name (2 letter code, eg, US):US
State or Province Name (full name, eg, California):California
Locality Name (eg, city name):San Jose
Organization Name (eg, company name):Brocade
Organizational Unit Name (eg, department name):Eng
Common Name (Fully qualified Domain Name, or IP address): 192.1.2.3

Generating CSR, file name is: 192.1.2.3.csr
Done.
```



Your CA may require specific codes for Country, State or Province, Locality, Organization, and Organizational Unit names. Make sure that your spelling is correct and matches the CA requirements. If the CA requires that the Common Name be specified as an FQDN, make sure that the fully qualified domain name is set on the domain name switch/director. The IP address or FQDN is the switch where the certificate gets installed.

You can also specify the hash type using the **-hash <sha1 | sha256>** option while generating the CSR. For example,

```
switch:admin> seccertutil gencsr -hash sha256 -country IN -state Kar -locality Bng -org brocade -
orgunit fos -cn switchip
```

4. Enter **secCertUtil export** to store the CSR.
5. Enter the requested information. You can use either FTP or SCP.

If you are set up for Secure Copy Protocol (SCP), you can select it; otherwise, select FTP. Enter the IP address of the switch on which you generated the CSR. Enter the remote directory name of the FTP server to which the CSR is to be sent. Enter your account name and password on the server.

The following example exports a CSR.

```
Select protocol [ftp or scp]: ftp
Enter IP address: 192.1.2.3
Enter remote directory: path_to_remote_directory
Enter Login Name: your account
Enter Password: your password
Success: exported CSR.
```

## Obtaining certificates

Once you have generated a CSR, you will need to follow the instructions on the website of the certificate issuing authority that you want to use; and then obtain the certificate.

Fabric OS and HTTPS support the following types of files from the Certificate Authority(CA):

- .cer (binary)
- .crt (binary)
- .pem (text)

Typically, the CA provides the certificate files listed in the following table.

**TABLE 32** SSL certificate files

Certificate file	Description
<i>name</i> .pem	The switch certificate.
<i>name</i> Root.pem	The root certificate. Typically, this certificate is already installed in the browser, but if not, you must install it.
<i>name</i> CA.pem	The CA certificate. It must be installed in the browser to verify the validity of the server certificate or server validation fails.

### NOTE

You must perform this procedure for each switch.

Use the following procedure to obtain a security certificate.

1. Generate and store the CSR as described in [Generating and storing a Certificate Signing Request](#) on page 196.
2. Open a web browser window on the management workstation and go to the CA website. Follow the instructions to request a certificate. Locate the area in the request form into which you are to paste the CSR.
3. Through a Telnet window, connect to the switch and log in using an account with admin permissions.

4. Enter the **secCertUtil showcscr** command. The contents of the CSR are displayed.
5. Locate the section that begins with "BEGIN CERTIFICATE REQUEST" and ends with "END CERTIFICATE REQUEST".
6. Copy and paste this section (including the BEGIN and END lines) into the area provided in the request form; then, follow the instructions to complete and send the request.

It may take several days to receive the certificates. If the certificates arrive by e-mail, save them to an FTP server. If the CA provides access to the certificates on an FTP server, make note of the path name and make sure you have a login name and password on the server.

## Installing a switch certificate

Before you import a switch certificate, be aware of the following:

- Certificate Authorities may provide their certificates in different encodings and different extensions. Be sure to save the certificate with the applicable file extension before you import the certificate to the switch.

For example, certificates that contain lines similar to the following are usually .pem encoded:

```
"-----BEGIN REQUEST-----" and "-----END REQUEST-----" (and may include the strings "x509" or "certificate")
```

- For Certificate Authorities that request information regarding the type of web server, Fabric OS uses the Apache web server running on Linux.
- If you try to import certificates of different sizes for a given switch, the import fails. If this happens, remove the previous certificate and then import the new certificate.

Use the following procedure to install a security certificate on a switch.

### NOTE

You must perform this procedure on each switch.

1. Connect to the switch and log in using an account with admin permissions.
2. Enter the **secCertUtil import** command.
3. Select a protocol, enter the IP address of the host on which the switch certificate is saved, and enter your login name and password.

### Example of installing a switch certificate in interactive mode

```
switch:admin> seccertutil import -config swcert -enable https
Select protocol [ftp or scp]: ftp
Enter IP address: 192.10.11.12
Enter remote directory: path_to_remote_directory
Enter certificate name (must have ".crt", ".cer", \
".pem" or ".psk" suffix): 192.1.2.3.crt
Enter Login Name: your_account
Enter Password: *****
Success: imported certificate [192.1.2.3.crt].
```

### Example of installing a switch certificate in noninteractive mode

```
switch:admin> seccertutil import -config swcert -enable https \
  -protocol ftp -ipaddr 192.10.11.12 -remotedir path_to_remote_directory \
  -certname 192.1.2.3.crt -login your_account -password passwd
Success: imported certificate [192.1.2.3.crt].
Certificate file in configuration has been updated.
Secure http has been enabled.
```

### Example of installing a common certificate in non-interactive mode

```
switch:admin> seccertutil import -commonswcert -config swcert -enable https -protocol scp -ipaddr
192.10.11.12 -remotedir
path_to_remote_directory -login cert -certname 192.1.2.3.pem
```

### Generating self-signed certificates

You can use the `secCertUtil Generate` command to generate a new key pair, sign the generated certificate with the private key, install the self-signed identity certificate within the switch for HTTPS, and enable the HTTPS service. You can also configure notification period for certificate(s) expiry through MAPS.

#### NOTE

Using this feature to generate self-signed certificates for FCAP is not supported.

1. Login to the device
2. Run the `secCertUtil generate -https` command.

```
switch:admin> seccertutil generate -https -keysize <1024|2048|4096|8192> -type <rsa|dsa> -hash
<sha1|sha256|sha512> -years <x >[-nowarn]
```

### The browser

The root certificate may already be installed on your browser, if not, you must install it. To see whether it is already installed, check the certificate store on your browser.

The next procedures are guides for installing root certificates to Internet Explorer and Mozilla Firefox browsers. For more detailed instructions, refer to the documentation that came with the certificate.

### Checking and installing root certificates on Internet Explorer

Use the following procedure to check and install a root security certificate on a switch using IE:

1. Select **Tools > Internet Options**.
2. Click the **Content** tab.
3. Click **Certificates**.
4. Click the **Intermediate** or **Trusted Root** tab and scroll the list to see if the root certificate is listed. Take the appropriate following action based on whether you find the certificate:
  - If the certificate is listed, you do not need to install it. You can skip the rest of this procedure.
  - If the certificate is not listed, click **Import**.
5. Follow the instructions in the Certificate Import wizard to import the certificate.

### Checking and installing root certificates on Mozilla Firefox

Use the following procedure to check and install a root security certificate on a switch using Firefox:

1. Select **Tools > Options**.
2. Click **Advanced**.
3. Click the **Encryption** tab.
4. Click **View Certificates > Authorities** and scroll the list to see if the root certificate is listed. For example, its name may have the form `nameRoot.crt`. Take the appropriate following action based on whether you find the certificate:

- If the certificate is listed, you do not need to install it. You can skip the rest of this procedure.
  - If the certificate is not listed, click **Import**.
5. Browse to the certificate location and select the certificate. For example, select *nameRoot.crt*.
  6. Click **Open** and follow the instructions to import the certificate.

## Root certificates for the Java plugin

For information on Java requirements, refer to [Browser and Java support](#) on page 195.

This procedure is a guide for installing a root certificate to the Java plugin on the management workstation. If the root certificate is not already installed to the plugin, you should install it. For more detailed instructions, refer to the documentation that came with the certificate and to the Oracle Corporation website ([www.oracle.com](http://www.oracle.com)).

## Installing a root certificate to the Java plugin

Use the following procedure to install a root certificate to the Java plugin.

1. Copy the root certificate file from its location on the FTP server to the Java plugin bin directory. For example, the bin location may be:

```
C: \program files\java\j2re1.6.0\bin
```

2. Open a Command Prompt window and change the directory to the Java plugin bin directory.
3. Enter the **keyTool** command and respond to the prompts.

### Example of installing a root certificate

```
C:\Program Files\Java\j2re1.6.0\bin> keytool -import -alias RootCert -file RootCert.crt -keystore ..\lib
\security\RootCerts
```

```
Enter keystore password: changeit
```

```
Owner: CN=Brocade, OU=Software, O=Brocade Communications, L=San Jose, ST=California, C=US
Issuer: CN=Brocade, OU=Software, O=Brocade Communications, L=San Jose, ST=California, C=US
Serial number: 0
Valid from: Thu Jan 15 16:27:03 PST 2007 until: Sat Feb 14 16:27:03 PST 2007
Certificate fingerprints:
    MD5: 71:E9:27:44:01:30:48:CC:09:4D:11:80:9D:DE:A5:E3
    SHA1: 06:46:C5:A5:C8:6C:93:9C:FE:6A:C0:EC:66:E9:51:C2:DB:E6:4F:A1
Trust this certificate? [no]: yes
```

```
Certificate was added to keystore
```

In the example, **changeit** is the default password and **RootCert** is an example root certificate name.

## Simple Network Management Protocol

Simple Network Management Protocol (SNMP) is a set of protocols for managing complex networks. SNMP protocols are application layer protocols. Using SNMP, devices within a network send messages, called protocol data units (PDUs), to different parts of a network. Network management using SNMP requires three components:

- SNMP Manager
- SNMP Agent
- Management Information Base (MIB)

## SNMP Manager

The SNMP Manager can communicate to the devices within a network using the SNMP protocol. Typically, SNMP Managers are network management systems (NMS) that manage networks by monitoring the network parameters, and optionally, setting parameters in managed devices. Normally, the SNMP Manager sends read requests to the devices that host the SNMP Agent, to which the SNMP Agent responds with the requested data. In some cases, the managed devices can initiate the communication, and send data to the SNMP Manager using asynchronous events called traps.

## SNMP Agent

The SNMP agent is a software that resides in the managed devices in the network, and collects data from these devices. Each device hosts an SNMP Agent. The SNMP Agent stores the data, and sends these when requested by an SNMP Manager. In addition, the Agent can asynchronously alert the SNMP Manager about events, by using special PDUs called traps.

## Management Information Base

SNMP Agents in the managed devices store the data about these devices in a database called a Management Information Base (MIB). The MIB is a hierarchical database, which is structured on the standard specified in the RFC 2578 (Structure of Management Information Version 2 (SMIv2)).

The MIB is a database of objects that can be used by a network management system to manage and monitor devices on the network. The MIB can be retrieved by a network management system that uses SNMP. The MIB structure determines the scope of management access allowed by a device. By using SNMP, a manager application can issue read or write operations within the scope of the MIB.

## Basic SNMP operation

Every Brocade device carries an agent and management information base (MIB). The agent accesses information about a device and makes it available to an SNMP network management station.

FIGURE 10 SNMP structure

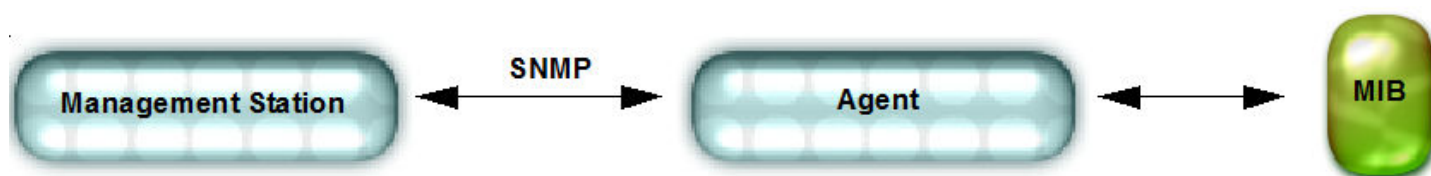

When active, the management station can get information or set information when it queries an agent. SNMP commands, such as **get**, **set**, and **getnext** are sent from the management station, and the agent replies once the value is obtained or modified. Agents use variables to report such data as the number of bytes and packets in and out of the device, or the number of broadcast messages sent and received. These variables are also known as *managed objects*. All managed objects are contained in the MIB.

FIGURE 11 SNMP query

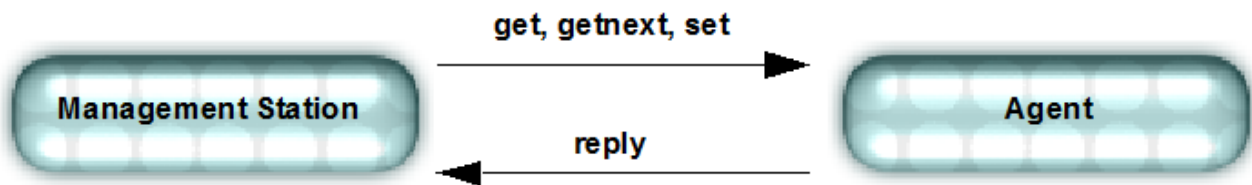

The management station can also receive *traps*, unsolicited messages from the switch agent if an unusual event occurs.

FIGURE 12 SNMP trap



The agent can receive queries from one or more management stations and can send traps to up to six management stations.

## Configuring SNMP using CLI

For information about Fabric OS commands for configuring SNMP, refer to the *Fabric OS Command Reference*.

### Configuring SNMP security level

The following example sets the SNMP security level to 1 (authentication only). This setting allows all SNMPv1 users to perform GET and SET operations on MIBs, but creates an exception for SNMPv3 users that do not have authentication and privacy privileges (noAuthnoPriv).

```
switch:admin> snmpconfig --set secLevel -snmpget 0 -snmpset 3
```

Select SNMP GET Security Levels are 0 = No security, 1 = Authentication only, 2 = Authentication and Privacy, 3 = No Access

Select SNMP SET Security Levels are 0 = No security, 1 = Authentication only, 2 = Authentication and Privacy, 3 = No Access

#### NOTE

The default options are **No security** for GET and **No access** for SET.

The following table shows the security level options.

TABLE 33 Security level options

Security level	Protocol	Query behavior	Traps
No security [0] (noAuthnoPriv)	SNMPv1	Allowed.	Sent.
	SNMPv3	Allowed.	Sent.

**TABLE 33** Security level options (continued)

Security level	Protocol	Query behavior	Traps
Authentication only [1] (authNoPriv)	SNMPv1	Allowed.	Sent.
	SNMPv3	All SNMPv3 users allowed except noAuthNoPriv users.	Sent for all SNMPv3 users except noAuthNoPriv users.
Authentication and Privacy [2] (authPriv)	SNMPv1	Not allowed.	Not Sent.
	SNMPv3	Only SNMPv3 users with authPriv privilege are allowed.	Sent only for authPriv users.
No Access [3]	SNMPv1	Not allowed.	Not Sent.
	SNMPv3		

## Supported protocol configurations for SNMPv3 users

The following table shows the authentication and privacy protocols supported for configuring SNMPv3 users.

**TABLE 34** Supported protocol options

Protocol	Options
Auth protocols	MD5 SHA noAuth
Priv protocols	DES noPriv AES128 AES256

## Configuring SNMPv3 user/traps

The following examples list how to configure SNMPv3 users/traps.

1. Create a user on the switch in non-VF Context using the **userconfig** command with the required role.

```
switch:admin> userconfig --add fa_adm -r fabricadmin -h0 -a 0-255
Setting initial password for fa_adm
Enter new password:*****
Re-type new password:*****
Account fa_adm has been successfully added.
```

Create a user on the switch in VF Context using the **userconfig** command with the required role.

```
switch:admin> userconfig --add sa_user -r switchadmin -l 1-128 -h1 -c admin
Setting initial password for sa_user
Enter new password:*****
Re-type new password:*****
Account sa_user has been successfully added.
```

2. Enter **snmpconfig --set snmpv3** to create the SNMPv3 user.

```
switch:admin> snmpconfig --set snmpv3

SNMP Informs Enabled (true, t, false, f): [true]

SNMPv3 user configuration(snmp user not configured in FOS user database will have physical AD and
admin role as the default):
User (rw): [password]
Auth Protocol [MD5(1)/SHA(2)/noAuth(3)]: (1..3) [1]
```

```

New Auth Passwd:
Priv Protocol [DES(1)/noPriv(2)/AES128(3)/AES256(4)]: (1..4) [3]
New Priv Passwd:
Engine ID: [80:00:05:23:01:ac:1a:1a:ac]
User (rw): [passpass]
Auth Protocol [MD5(1)/SHA(2)/noAuth(3)]: (1..3) [1]
New Auth Passwd:
Priv Protocol [DES(1)/noPriv(2)/AES128(3)/AES256(4)]: (1..4) [4]
New Priv Passwd:
Engine ID: [80:00:05:23:01:ac:1a:1a:ac]
User (rw): [snmpadmin3] password1
Auth Protocol [MD5(1)/SHA(2)/noAuth(3)]: (1..3) [3] 1
New Auth Passwd:
Verify Auth Passwd:
Priv Protocol [DES(1)/noPriv(2)/AES128(3)/AES256(4)]: (1..4) [2] 3
New Priv Passwd:
Verify Priv Passwd:
Engine ID: [00:00:00:00:00:00:00:00:00] 80:00:05:23:01:ac:1a:1a:ac]
User (ro): [snmpuser1]
Auth Protocol [MD5(1)/SHA(2)/noAuth(3)]: (1..3) [1]
New Auth Passwd:
Priv Protocol [DES(1)/noPriv(2)/AES128(3)/AES256(4)]: (1..4) [3]
New Priv Passwd:
Engine ID: [00:00:00:00:00:00:00:00:00]
User (ro): [snmpuser2]
Auth Protocol [MD5(1)/SHA(2)/noAuth(3)]: (1..3) [2]
New Auth Passwd:
Priv Protocol [DES(1)/noPriv(2)/AES128(3)/AES256(4)]: (1..4) [3]
New Priv Passwd:
Engine ID: [00:00:00:00:00:00:00:00:00]
User (ro): [admin]
Auth Protocol [MD5(1)/SHA(2)/noAuth(3)]: (1..3) [3]
Priv Protocol [DES(1)/noPriv(2)/AES128(3)/AES256(4)]: (2..2) [2]
Engine ID: [80:00:06:34:03]

```

```

SNMPv3 trap/inform recipient configuration:
Trap Recipient's IP address : [172.26.26.172]

```

```

Notify Type [TRAP(1)/INFORM(2)]: (1..2) [1] 2
UserIndex: (1..6) [1] 1
Trap recipient Severity level : (0..5) [4]
Trap recipient Port : (0..65535) [162]
Trap Recipient's IP address : [172.26.26.172]

```

```

Notify Type [TRAP(1)/INFORM(2)]: (1..2) [2] 1
UserIndex: (1..6) [1]
Trap recipient Severity level : (0..5) [5]
Trap recipient Port : (0..65535) [1000]
Trap Recipient's IP address : [172.26.26.172]

```

```

Notify Type [TRAP(1)/INFORM(2)]: (1..2) [1]
UserIndex: (1..6) [1]
Trap recipient Severity level : (0..5) [4]

```

```

SNMPv3 trap recipient configuration:
Trap Recipient's IP address : [0.0.0.0] 10.35.52.33
UserIndex: (1..6) [1]
Trap recipient Severity level : (0..5) [0] 5
Trap recipient Port : (0..65535) [162]
Trap Recipient's IP address : [0.0.0.0] 10.35.52.27
UserIndex: (1..6) [2]
Trap recipient Severity level : (0..5) [0] 5
Trap recipient Port : (0..65535) [162]
Trap Recipient's IP address : [0.0.0.0]
Trap Recipient's IP address : [0.0.0.0]
Trap Recipient's IP address : [0.0.0.0]
Trap Recipient's IP address : [0.0.0.0]
Committing configuration.....done.

```

```

Spike-7800:FID128:root> snmpconfig --show snmpv3

```

```

SNMP Informs = 1 (ON)

```



```

SNMPv3 USM configuration:
User 1 (rw): password
    Auth Protocol: MD5
    Priv Protocol: AES128
    Engine ID: 80:00:05:23:01:ac:1a:1a:ac
User 2 (rw): passpass
    Auth Protocol: MD5
    Priv Protocol: AES256
    Engine ID: 80:00:05:23:01:ac:1a:1a:ac
User 3 (rw): password1
    Auth Protocol: MD5
    Priv Protocol: AES128
    Engine ID: 80:00:05:23:01:ac:1a:1a:ac
User 4 (ro): snmpuser1
    Auth Protocol: MD5
    Priv Protocol: AES128
    Engine ID: 00:00:00:00:00:00:00:00:00
User 5 (ro): snmpuser2
    Auth Protocol: SHA
    Priv Protocol: AES128
    Engine ID: 00:00:00:00:00:00:00:00:00
User 6 (ro): admin
    Auth Protocol: noAuth
    Priv Protocol: noPriv
    Engine ID: 80:00:06:34:03

```

```

SNMPv3 Trap/Informs configuration:
Trap Entry 1: 172.26.26.172
    Trap Port: 162
    Trap User: password
    Trap recipient Severity level: 4
    Notify Type: INFORM(2)
Trap Entry 2: 172.26.26.172
    Trap Port: 1000
    Trap User: password
    Trap recipient Severity level: 5
    Notify Type: TRAP(1)
Trap Entry 3: 172.26.26.172
    Trap Port: 1000
    Trap User: password
    Trap recipient Severity level: 4
    Notify Type: TRAP(1)
Trap Entry 4: No trap recipient configured yet
    Notify Type: TRAP(1)
Trap Entry 5: No trap recipient configured yet
    Notify Type: TRAP(1)
Trap Entry 6: No trap recipient configured yet
    Notify Type: TRAP(1)

```

An example of the SNMPv3 user trap recipients configured with DNS names and IPv6 addresses:

```

switch:admin> snmpconfig --set snmpv3

SNMP Informs Enabled (true, t, false, f): [true]

SNMPv3 user configuration(snmp user not configured in FOS user database will have physical AD and
admin role as the default):
User (rw): [password]
Auth Protocol [MD5(1)/SHA(2)/noAuth(3)]: (1..3) [1]
New Auth Passwd:
Priv Protocol [DES(1)/noPriv(2)/AES128(3)/AES256(4)]: (1..4) [3]
New Priv Passwd:
Engine ID: [80:00:05:23:01:ac:1a:1a:ac]
User (rw): [passpass]
Auth Protocol [MD5(1)/SHA(2)/noAuth(3)]: (1..3) [1]
New Auth Passwd:
Priv Protocol [DES(1)/noPriv(2)/AES128(3)/AES256(4)]: (1..4) [4]
New Priv Passwd:
Engine ID: [80:00:05:23:01:ac:1a:1a:ac]
User (rw): [password1]

```

```

Auth Protocol [MD5(1)/SHA(2)/noAuth(3)]: (1..3) [1]
New Auth Passwd:
Priv Protocol [DES(1)/noPriv(2)/AES128(3)/AES256(4)]: (1..4) [3]
New Priv Passwd:
Engine ID: [80:00:05:23:01:ac:1a:1a:ac]
User (ro): [snmpuser1]
Auth Protocol [MD5(1)/SHA(2)/noAuth(3)]: (1..3) [1]
New Auth Passwd:
Priv Protocol [DES(1)/noPriv(2)/AES128(3)/AES256(4)]: (1..4) [3]
New Priv Passwd:
Engine ID: [00:00:00:00:00:00:00:00:00]
User (ro): [snmpuser2]
Auth Protocol [MD5(1)/SHA(2)/noAuth(3)]: (1..3) [2]
New Auth Passwd:
Priv Protocol [DES(1)/noPriv(2)/AES128(3)/AES256(4)]: (1..4) [3]
New Priv Passwd:
Engine ID: [00:00:00:00:00:00:00:00:00]
User (ro): [admin]
Auth Protocol [MD5(1)/SHA(2)/noAuth(3)]: (1..3) [3]
Priv Protocol [DES(1)/noPriv(2)/AES128(3)/AES256(4)]: (2..2) [2]
Engine ID: [80:00:06:34:03]

SNMPv3 trap/inform recipient configuration:
Trap Recipient's IP address : [172.26.26.172] fe80::224:1dff:fef6:3f98

Notify Type [TRAP(1)/INFORM(2)]: (1..2) [2]
UserIndex: (1..6) [1]
Trap recipient Severity level : (0..5) [4]
Trap recipient Port : (0..65535) [162]
Trap Recipient's IP address : [172.26.26.172] HCL0389U.corp.brocade.com

Notify Type [TRAP(1)/INFORM(2)]: (1..2) [1]
UserIndex: (1..6) [1]
Trap recipient Severity level : (0..5) [5]
Trap recipient Port : (0..65535) [1000]
Trap Recipient's IP address : [172.26.26.172]

Notify Type [TRAP(1)/INFORM(2)]: (1..2) [1]
Committing configuration.....done.
Spike-7800:FID128:root> snmpconfig --show snmpv3

SNMP Informs = 1 (ON)

SNMPv3 USM configuration:
User 1 (rw): password
    Auth Protocol: MD5
    Priv Protocol: AES128
    Engine ID: 80:00:05:23:01:ac:1a:1a:ac
User 2 (rw): passpass
    Auth Protocol: MD5
    Priv Protocol: AES256
    Engine ID: 80:00:05:23:01:ac:1a:1a:ac
User 3 (rw): password1
    Auth Protocol: MD5
    Priv Protocol: AES128
    Engine ID: 80:00:05:23:01:ac:1a:1a:ac
User 4 (ro): snmpuser1
    Auth Protocol: MD5
    Priv Protocol: AES128
    Engine ID: 00:00:00:00:00:00:00:00:00
User 5 (ro): snmpuser2
    Auth Protocol: SHA
    Priv Protocol: AES128
    Engine ID: 00:00:00:00:00:00:00:00:00
User 6 (ro): admin
    Auth Protocol: noAuth
    Priv Protocol: noPriv
    Engine ID: 80:00:06:34:03

SNMPv3 Trap/Informs configuration:
Trap Entry 1:      fe80::224:1dff:fef6:3f98
Trap Port: 162

```

```

Trap User: password
Trap recipient Severity level: 4
Notify Type: INFORM(2)
Trap Entry 2:      HCL0389U.corp.brocade.com
Trap Port: 1000
Trap User: password
Trap recipient Severity level: 5
Notify Type: TRAP(1)
Trap Entry 3:      172.26.26.172
Trap Port: 1000
Trap User: password
Trap recipient Severity level: 4
Notify Type: TRAP(1)
Trap Entry 4:      No trap recipient configured yet
Notify Type: TRAP(1)
Trap Entry 5:      No trap recipient configured yet
Notify Type: TRAP(1)
Trap Entry 6:      No trap recipient configured yet
Notify Type: TRAP(1)

```

To display the test traps associated with the real MIBs supported in Fabric OS:

```

switch:admin> snmptraps --show

# |Mib Name          |Supported Traps
---|-----|-----
001|SW-MIB            |sw-fc-port-scen
|                  |sw-ip-v6-change-trap
|                  |sw-pmgr-event-trap
|                  |sw-event-trap
|                  |sw-fabric-reconfig-trap
|                  |sw-fabric-segment-trap
|                  |sw-state-change-trap
|                  |sw-zone-config-change-trap
|                  |sw-port-move-trap
|                  |sw-brcd-generic-trap
|                  |sw-device-status-trap
002|FICON-MIB        |link-rnid-device-registration
|                  |link-rnid-device-deregistration
|                  |link-lirr-listener-added
|                  |link-lirr-listener-removed
|                  |link-rlir-failure-incident
003|FA-MIB           |conn-unit-status-change
|                  |conn-unit-port-status-change
|                  |conn-unit-event-trap
004|MIB-2            |cold-restart-trap
|                  |warm-restart-trap
005|IF-MIB           |if-link-up-trap
|                  |if-link-down-trap
006|RFC1157          |snmp-authetication-trap
007|HA-MIB           |fru-status-change-trap
|                  |fru-history-trap
|                  |cp-status-change-trap
008|T11-FC-ZONE-SERVER-MIB|t11zsRequestRejectNotify
|                  |t11zsMergeSuccessNotify
|                  |t11zsMergeFailureNotify
|                  |t11zsDefZoneChangeNotify
|                  |t11zsActivateNotify

```

#### NOTE

The T11-FC-ZONE-SERVER-MIB and its traps are for internal use only.

To send all traps to the configured recipients:

```

switch:admin> snmpTraps --send
Number of traps sent : 30

```

To send all traps to the recipient 10.35.52.33:

```
switch:admin> snmpTraps --send -ip_address 10.35.52.33
Number of traps sent : 30
```

To send the sw-fc-port-scn trap to the configured recipients:

```
switch:admin> snmpTraps --send -trap_name sw-fc-port-scn
Number of traps sent : 1
```

To send the sw-fc-port-scn trap to the recipient 10.35.52.33:

```
switch:admin> snmpTraps --send -trap_name sw-fc-port-scn -ip_address 10.35.52.33
Number of traps sent : 1
```

To unblock port traps on all the ports or on a specific port:

```
switch:admin> snmptraps --unblock -ports ALL
switch:admin> snmptraps --unblock -port 1/10
```

To block port traps on slot 1 and port 10:

```
Switch:admin> snmptraps --block -port 1/10
```

#### NOTE

Blocking of all ports using the **ALL** option is not allowed.

The following example displays the accessControl configuration.

```
switch:admin> snmpconfig --set accessControl
SNMP access list configuration:
Access host subnet area in dot notation: [0.0.0.0] 192.168.0.0
Read/Write? (true, t, false, f): [true]
Access host subnet area in dot notation: [0.0.0.0] 10.32.148.0
Read/Write? (true, t, false, f): [true] f
Access host subnet area in dot notation: [0.0.0.0]
Read/Write? (true, t, false, f): [true]
Access host subnet area in dot notation: [0.0.0.0] 10.33.0.0
Read/Write? (true, t, false, f): [true] f
Access host subnet area in dot notation: [0.0.0.0]
Read/Write? (true, t, false, f): [true]
Access host subnet area in dot notation: [0.0.0.0]
Read/Write? (true, t, false, f): [true]
Committing configuration...done.
```

The following examples display the **mibCapability** configuration.

To enable the swEventTrap of the SW-MIB category only (this operation disables all other SNMP traps in this MIB category):

```
switch:admin> snmpconfig --set mibCapability -mib_name SW-MIB -bitmask 0x10
Operation succeeded
```

```
switch:admin> snmpconfig --show mibCapability
[...]
SW-MIB: NO
swFault: NO
swSensorScn: NO
swFCPortScn: NO
swEventTrap: YES
    DesiredSeverity:None
swIPv6ChangeTrap: NO
swPmgrEventTrap: NO
swFabricReconfigTrap: NO
swFabricSegmentTrap: NO
swExtTrap: NO
swStateChangeTrap: NO
swPortMoveTrap: NO
swBracdGenericTrap: NO
```

```
swDeviceStatusTrap: NO
swZoneConfigChangeTrap: NO
(output truncated)
```

To enable the SW-MIB only without changing the current trap configuration:

```
switch:admin> snmpconfig --enable mibCapability -mib_name SW-MIB
Operation succeeded

switch:admin> snmpconfig --show mibCapability
[...]
SW-MIB: YES
swFault: NO
swSensorScn: NO
swFCPortScn: NO
swEventTrap: YES
    DesiredSeverity:None
swTrackChangesTrap: NO
swIPv6ChangeTrap: NO
swPmgrEventTrap: NO
swFabricReconfigTrap: NO
swFabricSegmentTrap: NO
swExtTrap: NO
swStateChangeTrap: NO
swPortMoveTrap: NO
swBrcdGenericTrap: NO
swDeviceStatusTrap: NO
swZoneConfigChangeTrap: NO
(output truncated)
```

To re-enable all traps under the SW-MIB category after they were disabled:

```
switch:admin> snmpconfig --set mibCapability -mib_name SW-MIB -bitmask 0xFFFF
Operation succeeded

switch:admin> snmpconfig --show mibCapability
[...]
SW-MIB: YES
swFault: YES
swSensorScn: YES
swFCPortScn: YES
swEventTrap: YES
    DesiredSeverity:None
swTrackChangesTrap: YES
swIPv6ChangeTrap: YES
swPmgrEventTrap: YES
swFabricReconfigTrap: YES
swFabricSegmentTrap: YES
swExtTrap: YES
swStateChangeTrap: YES
swPortMoveTrap: YES
swBrcdGenericTrap: YES
swDeviceStatusTrap: YES
swZoneConfigChangeTrap: YES
(output truncated)
```

To display the configuration for all MIBs and associated traps:

```
switch:admin> snmpconfig --show mibcapability
FE-MIB: YES
SW-MIB: YES
FA-MIB: YES
FICON-MIB: YES
HA-MIB: YES
FCIP-MIB: YES
IF-MIB: YES
BROCADE-MAPS-MIB: YES
T11-FC-ZONE-SERVER-MIB: NO
SW-TRAP: YES
    swFCPortScn: YES
    swEventTrap: YES
```

```

DesiredSeverity:None
swIPv6ChangeTrap: YES
swFmgrEventTrap: YES
swFabricReconfigTrap: YES
swFabricSegmentTrap: YES
swExtTrap: NO
swStateChangeTrap: NO
swPortMoveTrap: NO
swBrcdGenericTrap: YES
swDeviceStatusTrap: YES
swZoneConfigChangeTrap: NO
FA-TRAP: YES
connUnitStatusChange: YES
connUnitEventTrap: YES
connUnitPortStatusChange: YES
FICON-TRAP: YES
linkRNIDDeviceRegistration: YES
linkRNIDDeviceDeRegistration: YES
linkLIRRLListenerAdded: YES
linkLIRRLListenerRemoved: YES
linkRLIRFailureIncident: YES
HA-TRAP: YES
fruStatusChanged: YES
cpStatusChanged: YES
fruHistoryTrap: YES
IF-TRAP: YES
linkDown: YES
linkUp: YES
BD-TRAP: YES
bdTrap: YES
bdClearTrap: YES
MAPS-TRAP: YES
mapsTrapAM: YES
T11-FC-ZONE-SERVER-TRAP: NO
t11ZsRequestRejectNotify: NO
t11ZsMergeFailureNotify: NO
t11ZsMergeSuccessNotify: NO
t11ZsDefZoneChangeNotify: NO
t11ZsActivateNotify: NO

```

To set the system group:

```

switch:admin> snmpconfig --set systemgroup -syscontact "Sys contact" -authTrapEnabled false -
sysdescr "Filed Support" -syslocation "Sys Location"
Committing configuration.....done.
switch:admin> snmpconfig --show systemgroup
sysDescr = Filed Support
sysLocation = Sys Location
sysContact = Sys contact
authTrapEnabled = 0 (OFF)

```

### 3. Set the security level.

```

switch:admin> snmpconfig --set secLevel -snmpget 2 -snmpset 2
switch:admin> snmpconfig --show secLevel
GET security level = 2, SET level = 2
SNMP GET Security Level: Authentication and Privacy
SNMP SET Security Level: Authentication and Privacy

```

To set the security level to default:

```

switch:admin> snmpconfig --default seclevel
GET security level = 0, SET level = 3
SNMP GET Security Level: No security
SNMP SET Security Level: No Access
SNMP GET Security Level will be set to 'No Security'
SNMP SET Security Level will be set to 'No Access'
Do you want to continue? (yes, y, no, n): [no] y

switch:admin> snmpconfig --show seclevel

```

```
GET security level = 0, SET level = 3
SNMP GET Security Level: No security
SNMP SET Security Level: No Access
```

#### 4. Set audit interval.

```
switch:admin> snmpconfig --set auditinterval -interval 31
Committing configuration....done.
Spike-7800:FID128:root> snmpconfig --show auditInterval
SNMP Audit Interval (in min): 31
```

Set to the default audit interval.

```
switch:admin> snmpconfig --default auditInterval
*****
This command will reset the agent's audit log interval configuration back to factory default
*****
SNMP Audit Interval (in min): 31

*****
Are you sure? (yes, y, no, n): [no] y
Spike-7800:FID128:root> snmpconfig --show auditInterval
SNMP Audit Interval (in min): 60
```

#### 5. In the Manager (SNMP Browser), create a user snmpadmin1 with Authentication protocol as noAuth, Privacy protocol as noPriv, set the password and set the trap port as 162. (Same values are set as in the switch SNMPv3 configuration.)

##### Notes:

- SNMPv3 supports AES-128, AES-256, and DES protocols.
- For resolving AES-256 protocol in the USM MIB walk, the eso Consortium MIB has to be loaded.

## Telnet protocol

Telnet is enabled by default. To prevent passing clear text passwords over the network when connecting to the switch, you can block the Telnet protocol using an IP filter policy. For more information on IP filter policies, refer to [IP Filter policy](#) on page 236.

### ATTENTION

Before blocking Telnet, make sure you have an alternate method of establishing a connection with the switch.

## Blocking Telnet

If you create a new policy using commands with just one rule, all the missing rules have an implicit deny and you lose all IP access to the switch, including Telnet, SSH, and management ports.

Use the following procedure to block Telnet access.

1. Connect to the switch and log in using an account with admin permissions.
2. Clone the default policy by entering the **ipFilter --clone** command.

```
switch:admin> ipfilter --clone BlockTelnet -from default_ipv4
```

3. Save the new policy by entering the **ipFilter --save** command.

```
switch:admin> ipfilter --save BlockTelnet
```

- Verify the new policy exists by entering the `ipFilter --show` command.

```
switch:admin> ipfilter --show
```

- Add a rule to the policy, by entering the `ipFilter --addrule` command.

```
switch:admin> ipfilter --addrule BlockTelnet -rule 1 -sip any -dp 23 -proto tcp -act deny
```

### ATTENTION

The rule number assigned must precede the default rule number for this protocol. For example, in the defined policy, the Telnet rule number is 2. Therefore, to effectively block Telnet, the rule number to assign must be 1. If you choose not to use 1, you must delete the Telnet rule number 2 after adding this rule. Refer to [Deleting a rule from an IP Filter policy](#) on page 241 for more information on deleting IP filter rules.

- Save the new IP filter policy by entering the `ipFilter --save` command.
- Verify the new policy is correct by entering the `ipFilter --show` command.
- Activate the new IP filter policy by entering the `ipFilter --activate` command.

```
switch:admin> ipfilter --activate BlockTelnet
```

- Verify the new policy is active (the `default_ipv4` policy should be displayed as **defined**).

```
switch:admin> ipfilter --show
```

```
Name: default_ipv4, Type: ipv4, State: defined
```

Rule	Source IP	Protocol	Dest Port	Action
1	any	tcp	22	permit
2	any	tcp	23	permit
3	any	tcp	80	permit
4	any	tcp	443	permit
5	any	udp	161	permit
6	any	udp	123	permit
7	any	tcp	600 - 1023	permit
8	any	udp	600 - 1023	permit

```
Name: default_ipv6, Type: ipv6, State: active
```

Rule	Source IP	Protocol	Dest Port	Action
1	any	tcp	22	permit
2	any	tcp	23	permit
3	any	tcp	80	permit
4	any	tcp	443	permit
5	any	udp	161	permit
6	any	udp	123	permit
7	any	tcp	600 - 1023	permit
8	any	udp	600 - 1023	permit

```
Name: BlockTelnet, Type: ipv4, State: active (modified)
```

Rule	Source IP	Protocol	Dest Port	Action
1	any	tcp	23	deny
2	any	tcp	22	permit
3	any	tcp	80	permit
4	any	tcp	443	permit
5	any	udp	161	permit
6	any	udp	123	permit
7	any	tcp	600 - 1023	permit
8	any	udp	600 - 1023	permit

## Unblocking Telnet

Use the following procedure to unblock Telnet access.



1. Connect to the switch through a serial port or SSH and log in as admin.
2. Enter the `ipfilter --delete` command.  
Refer to [Deleting a rule from an IP Filter policy](#) on page 241 for more information on deleting IP filter rules.
3. To permanently delete the policy, type the `ipfilter --save` command.

**ATTENTION**

If you deleted the rule to permit Telnet, you must add a rule to permit Telnet.

## Listener applications

Brocade switches block Linux subsystem listener applications that are not used to implement supported features and capabilities.

The following table lists the listener applications that Brocade switches either block or do not start. Note that RPC ports are blocked.

**TABLE 35** Blocked listener applications

Listener application	Brocade DCX and DCX 8510 Backbone families	Brocade switches
chargen	Disabled	Disabled
daytime	Disabled	Disabled
discard	Disabled	Disabled
echo	Disabled	Disabled
ftp	Disabled	Disabled
rexec	Block with packet filter	Disabled
rlogin	Block with packet filter	Disabled
rsh	Block with packet filter	Disabled
rstats	Disabled	Disabled
rusers	Disabled	Disabled
time	Block with packet filter	Disabled

## Ports and applications used by switches

If you are using the FC-FC Routing Service, be aware that the `secModeEnable` command is not supported.

The following table lists the defaults for accessing hosts, devices, switches, and zones.

**TABLE 36** Access defaults

	Access default
Hosts	Any host can access the fabric by SNMP.
	Any host can Telnet to any switch in the fabric.
	Any host can establish an HTTP connection to any switch in the fabric.
	Any host can establish an API connection to any switch in the fabric.
Devices	All devices can access the management server.
	Any device can connect to any FC port in the fabric.
Switch access	Any switch can join the fabric.
	All switches in the fabric can be accessed through a serial port.
Zoning	No zoning is enabled.

## Port configuration

The following table provides information on ports that the switch uses. When configuring the switch for various policies, take into consideration firewalls and other devices that may sit between switches in the fabric and your network or between the managers and the switch.

**TABLE 37** Port information

Port	Type	Common use	Comment
22	TCP	SSH, SCP	
23	TCP	Telnet	Use the <b>ipfilter</b> command to block the port.
80	TCP	HTTP	Use the <b>ipfilter</b> command to block the port.
123	UDP	NTP	
161	UDP	SNMP	Disable the SNMP service on the remote host if you do not use it, or filter incoming UDP packets going to this port.
443	TCP	HTTPS	Use the <b>ipfilter</b> command to block the port.

# Configuring Security Policies

---

• ACL policies overview.....	215
• ACL policy management.....	216
• FCS policies.....	218
• Device Connection Control policies.....	222
• SCC Policies.....	226
• Authentication policy for fabric elements.....	227
• IP Filter policy.....	236
• Policy database distribution.....	242
• Management interface security.....	247

## ACL policies overview

Each supported Access Control List (ACL) policy listed below is identified by a specific name, and only one policy of each type can exist, except for DCC policies. Policy names are case-sensitive and must be entered in all uppercase. Fabric OS provides the following policies:

- **Fabric configuration server** (FCS) policy -- Used to restrict which switches can change the configuration of the fabric.
- **Device connection control** (DCC) policies -- Used to restrict which Fibre Channel device ports can connect to which Fibre Channel switch ports.
- **Switch connection control** (SCC) policy -- Used to restrict which switches can join with a switch.

## How the ACL policies are stored

The policies are stored in a local database. The database contains the ACL policy types of FCS, DCC, SCC, and IPFilter. The number of policies that may be defined is limited by the size of the database. FCS, SCC and DCC policies are all stored in the same database.

The limit for security policy database size is set to 1Mb. The policies are grouped by state and type. A policy can be in either of the following states:

- Active, which means the policy is being enforced by the switch.
- Defined, which means the policy has been set up but is not enforced.

Policies with the same state are grouped together in a *Policy Set*. Each switch has the following two sets:

- *Active policy set*, which contains ACL policies being enforced by the switch.
- *Defined policy set*, which contains a copy of all ACL policies on the switch.

When a policy is activated, the defined policy either replaces the policy with the same name in the active set or becomes a new active policy. If a policy appears in the defined set but not in the active set, the policy was saved but has not been activated. If a policy with the same name appears in both the defined and active sets but they have different values, then the policy has been modified but the changes have not been activated.

## Virtual Fabric considerations for ACL policies

ACL policies such as DCC, SCC, and FCS can be configured on each logical switch. The limit for security policy database size is set to 1Mb per logical switch.

## Policy members

The FCS, DCC and SCC policy members are specified by device port WWN, switch WWN, domain IDs, or switch names, depending on the policy. The valid methods for specifying policy members are listed in [Table 38](#).

**TABLE 38** Valid methods for specifying policy members

Policy name	Device port WWN or Fabric port WWN	Switch WWN	Domain ID	Switch name
FCS_POLICY	No	Yes	Yes	Yes
DCC_POLICY_ <i>nnn</i>	Yes	Yes	Yes	Yes
SCC_POLICY	No	Yes	Yes	Yes

## ACL policy management

All policy modifications are temporarily stored in volatile memory until those changes are saved or activated. You can create multiple sessions to the switch from one or more hosts. It is recommended you make changes from one switch only to prevent multiple transactions from occurring. Each logical switch will have its own access control list.

The FCS, SCC and DCC policies in Secure Fabric OS are not interchangeable with Fabric OS FCS, SCC and DCC policies. Uploading and saving a copy of the Fabric OS configuration after creating policies is strongly recommended. For more information on configuration uploads, see [Maintaining the Switch Configuration File](#) on page 257.

### NOTE

All changes, including the creation of new policies, are saved and activated on the local switch only--unless the switch is in a fabric that has a strict or tolerant fabric-wide consistency policy for the ACL policy type for SCC or DCC. See [Policy database distribution](#) on page 242 for more information on the database settings and fabric-wide consistency policy.

## Displaying ACL policies

You can view the active and defined policy sets at any time. In addition, within a defined policy set, any policies created in the same login session will be listed, but these policies are automatically deleted if you log out without saving them.

To view the active and defined policy sets, complete the following steps.

1. Connect to the switch and log in using an account with admin permissions, or an account with "O" permission for the Security RBAC class of commands.
2. Enter **secPolicyShow**.

The following example shows the command and a typical response

```
switch:admin> secPolicyShow
```

---

ACTIVE POLICY SET

---

DEFINED POLICY SET

## Saving changes without activating the policies

1. Connect to the switch and log in using an account with admin permissions, or an account with OM permissions for the Security RBAC class of commands.
2. Enter the **secPolicySave** command.

## Activating ACL policy changes

You can implement changes to the ACL policies using the **secPolicyActivate** command. This saves the changes to the active policy set and activates all policy changes since the last time the command was issued. You cannot activate policies on an individual basis; all changes to the entire policy set are activated by the command. Until a **secPolicySave** or **secPolicyActivate** command is issued, all policy changes are in volatile memory only and are lost upon rebooting.

1. Connect to the switch and log in using an account with admin permissions, or an account with OM permissions for the Security RBAC class of commands.
2. Type the **secPolicyActivate** command.

Example of activating policy changes

```
switch:admin> secpolicyactivate
About to overwrite the current Active data.
ARE YOU SURE (yes, y, no, n): [no] y
```

## Deleting an ACL policy

1. Connect to the switch and log in using an account with admin permissions, or an account with OM permissions for the Security RBAC class of commands.
2. Enter the **secPolicyDelete** command, specifying the name of the ACL policy to delete.

```
secpolicydelete "policy_name"
```

3. Save and activate the policy deletion by entering the **secPolicyActivate** command.

Example of deleting an ACL policy

```
switch:admin> secpolicydelete "DCC_POLICY_010"
About to delete policy Finance_Policy.
Are you sure (yes, y, no, n):[no] y
Finance_Policy has been deleted.
```

## Adding a member to an existing ACL policy

As soon as a policy has been activated, the aspect of the fabric managed by that policy is enforced.

1. Connect to the switch and log in using an account with admin permissions, or an account with OM permissions for the Security RBAC class of commands.
2. Enter the **secPolicyAdd** command.
3. To implement the change immediately, enter the **secPolicyActivate** command.

For example, to add a member to the SCC\_POLICY using the switch WWN:

```
switch:admin> secpolicyadd "SCC_POLICY", "12:24:45:10:0a:67:00:40"
Member(s) have been added to SCC_POLICY.
```

Example of adding members to the DCC policy

To add two devices to the DCC policy, and to attach domain 3 ports 1 and 3 (WWNs of devices are 11:22:33:44:55:66:77:aa and 11:22:33:44:55:66:77:bb):

```
switch:admin> secpolicyadd "DCC_POLICY_abc",
"11:22:33:44:55:66:77:aa;11:22:33:44:55:66:77:bb;3(1,3)"
```

## Removing a member from an ACL policy

As soon as a policy has been activated, the aspect of the fabric managed by that policy is enforced.

1. Connect to the switch and log in using an account with admin permissions, or an account with OM permissions for the Security RBAC class of commands.
2. Enter the **secPolicyRemove** command.
3. To implement the change immediately, enter the **secPolicyActivate** command.

Example of removing a member

For example, to remove a member that has a WWN of 12:24:45:10:0a:67:00:40 from the SCC\_POLICY:

```
switch:admin> secpolicyremove "SCC_POLICY", "12:24:45:10:0a:67:00:40"
Member(s) have been removed from SCC_POLICY.
```

## Abandoning unsaved ACL policy changes

You can abandon all ACL policy changes that have not yet been saved.

1. Connect to the switch and log in using an account with admin permissions, or an account with OM permissions for the Security RBAC class of commands.
2. Enter the **secPolicyAbort** command.

Example of aborting unsaved changes

```
switch:admin> secpolicyabort
Unsaved data has been aborted.
```

All changes since the last time the **secPolicySave** or **secPolicyActivate** commands were entered are aborted.

## FCS policies

Fabric configuration server (FCS) policy in base Fabric OS may be performed on a local switch basis and may be performed on any switch in the fabric.

The FCS policy is not present by default, but must be created. When the FCS policy is created, the WWN of the local switch is automatically included in the FCS list. Additional switches can be included in the FCS list. The first switch in the list becomes the Primary FCS switch.

Switches in the fabric are designated as either a Primary FCS, backup FCS, or non-FCS switch. Only the Primary FCS switch is allowed to modify and distribute the database within the fabric. Automatic distribution is supported and you can either configure the switches in your fabric to accept the FCS policy or manually distribute the FCS policy. Changes made to the FCS policy are saved to permanent memory only after the changes have been saved or activated; they can be aborted later if you have set your fabric to distribute the changes manually.

**TABLE 39** FCS policy states

Policy state	Characteristics
No active policy	Any switch can perform fabric-wide configuration changes.
Active policy with one entry	A Primary FCS switch is designated (local switch), but there are no backup FCS switches. If the Primary FCS switch becomes unavailable for any reason, the fabric is left without an FCS switch.

**TABLE 39** FCS policy states (continued)

Policy state	Characteristics
Active policy with multiple entries	A Primary FCS switch and one or more backup FCS switches are designated. If the Primary FCS switch becomes unavailable, the next switch in the list becomes the Primary FCS switch.

## FCS policy restrictions

The backup FCS switches normally cannot modify the policy. However, if the Primary FCS switch in the policy list is not reachable, then a backup FCS switch is allowed to modify the policy.

Once an FCS policy is configured and distributed across the fabric, only the Primary FCS switch can perform certain operations. Operations that affect fabric-wide configuration are allowed only from the Primary FCS switch. Backup and non-FCS switches cannot perform security, zoning and AD operations that affect the fabric configuration. The following error message is returned if a backup or non-FCS switch tries to perform these operations:

```
Can only execute this command on the Primary FCS switch.
```

Operations that do not affect the fabric configuration, such as **show** or local switch commands, are allowed on backup and non-FCS switches.

FCS enforcement applies only for user-initiated fabric-wide operations. Internal fabric data propagation because of a fabric merge is not blocked. Consequently, a new switch that joins the FCS-enabled fabric could still propagate the AD and zone database.

Table 40 shows the commands for switch operations for Primary FCS enforcement.

**TABLE 40** FCS switch operations

Allowed on FCS switches	Allowed on all switches
secPolicyAdd (Allowed on all switches for SCC and DCC policies as long as it is not fabric-wide)	secPolicyShow
secPolicyCreate (Allowed on all switches for SCC and DCC policies as long as it is not fabric-wide)	fddCfg --localaccept or fddCfg --localreject
secPolicyDelete (Allowed on all switches for SCC and DCC policies as long as its not fabric-wide)	userconfig, Passwd, Passwdcfg (Fabric-wide distribution is not allowed from a backup or non-FCS switch.)
secPolicyRemove (Allowed on all switches for SCC and DCC policies as long as its not fabric-wide)	secPolicyActivate
fddCfg -- fabwideset	secPolicySave
Any fabric-wide commands	secPolicyAbort
All zoning commands except the show commands	SNMP commands
All AD commands	configupload
	Any local-switch commands

In Fabric OS v7.1.0 and later, to avoid segmentation of ports due to a member-list order mismatch, security policy members are sorted based on WWN. By default, DCC and SCC policy members are sorted based on WWN. Switches running earlier Fabric OS versions will have the member list in the unsorted manner. Any older-version switch with a policy already created in unsorted order will have port segmentation due to order mismatch when attempting to join any switch with Fabric OS v7.1.0 or later. To overcome the order mismatch, you can modify the member list in the switch by using the **-legacy** option in the **secPolicyAdd** and **secPolicyCreate** commands.

## Ensuring fabric domains share policies

Whether your intention is to create new FCS policies or manage your current FCS policies, you must follow certain steps to ensure the domains throughout your fabric have the same policy.

The local-switch WWN cannot be deleted from the FCS policy.

1. Create the FCS policy using the **secPolicyCreate** command.
2. Activate the policy using the **secPolicyActivate** command.

If the command is not entered, the changes are lost when the session is logged out.

3. Distribute the policy using the **distribute -p** command.

```
distribute -p policy_list -d switch_list
```

You can specify an asterisk (\*) for the *switch\_list* to send the policy to all switches.

## Creating an FCS policy

1. Connect to the switch and log in using an account with admin permissions, or an account with OM permissions for the Security RBAC class of commands.
2. Enter the **secPolicyCreate "FCS\_POLICY"** command.

Example of creating an FCS policy

The following example creates an FCS policy that allows a switch with domain ID 2 to become a primary FCS and domain ID 4 to become a backup FCS:

```
switch:admin> secpolicycreate "FCS_POLICY", "2;4"  
FCS_POLICY has been created
```

3. To save or activate the new policy, enter either the **secPolicySave** or the **secPolicyActivate** command. Once the policy has been activated you can distribute the policy.

### NOTE

FCS policy must be consistent across the fabric. If the policy is inconsistent in the fabric, then you will not be able to perform any fabric-wide configurations from the primary FCS.

## Modifying the order of FCS switches

1. Log in to the Primary FCS switch using an account with admin permissions, or an account with OM permissions for the Security RBAC class of commands.
2. Type **secPolicyShow "Defined", "FCS\_POLICY"** .

This displays the WWNs of the current Primary FCS switch and backup FCS switches.

3. Enter the **secPolicyFCSMove** command.

```
secpolicyfcsmove from to
```

Specify the existing and new positions of the switch in the list using the *from* and *to* options. Alternatively, you can specify the positions interactively at the prompts.

Example of moving an FCS policy



The following example moves a backup FCS switch from position 2 to position 3 in the FCS list, using interactive mode:

```
primaryfcs:admin> secpolicyfcsmove
Pos   Primary WWN                               DId swName.
=====
1     Yes      10:00:00:60:69:10:02:18   1 switch5.
2     No       10:00:00:60:69:00:00:5a   2 switch60.
3     No       10:00:00:60:69:00:00:13   3 switch73.
Please enter position you'd like to move from : (1..3) [1] 2
Please enter position you'd like to move to   : (1..3) [1] 3

-----
DEFINED POLICY SET
FCS_POLICY
Pos   Primary WWN                               DId swName
-----
1     Yes      10:00:00:60:69:10:02:18   1 switch5.
2     No       10:00:00:60:69:00:00:13   3 switch73.
3     No       10:00:00:60:69:00:00:5a   2 switch60.
-----
```

4. Enter the **secPolicyActivate** command to activate and save the new order.

## FCS policy distribution

The FCS policy can be automatically distributed using the **fddCfg --fabwideset** command or it can be manually distributed to the switches using the **distribute -p** command. Each switch that receives the FCS policy must be configured to receive the policy. To configure the switch to accept distribution of the FCS policy, refer to [Database distribution settings](#) on page 243.

Database distributions may be initiated from only the Primary FCS switch. FCS policy configuration and management is performed using the command line or a manageability interface.

Only the Primary FCS switch is allowed to distribute the database. The FCS policy can be manually distributed across the fabric using the **distribute -p** command. Since this policy is distributed manually, the command **fddCfg --fabwideset** is used to distribute a fabric-wide consistency policy for FCS policy in an environment consisting of only Fabric OS v6.2.0 and later switches.

FCS enforcement for the **distribute** command is handled differently for FCS and other databases in an FCS fabric:

- For an FCS database, the enforcement allows any switch to initiate the distribution. This is to support FCS policy creation specifying a remote switch as Primary.
- For other database distributions, only the Primary FCS switch can initiate the distribution.

The FCS policy distribution is allowed to be distributed from a switch in the FCS list. However, if none of the FCS switches in the existing FCS list are reachable, receiving switches accept distribution from any switch in the fabric. To learn more about how to distribute policies, refer to [ACL policy distribution to other switches](#) on page 244.

Local switch configuration parameters are needed to control whether a switch accepts or rejects distributions of FCS policy and whether the switch is allowed to initiate distribution of an FCS policy. A configuration parameter controls whether the distribution of the policy is accepted or rejected on the local switch. Setting the configuration parameter to accept indicates distribution of the policy will be accepted and distribution may be initiated using the **distribute -p** command. Setting the configuration parameter to reject indicates the policy distribution is rejected and the switch may not distribute the policy.

The default value for the distribution configuration parameter is *accept*, which means the switch accepts all database distributions and is able to initiate a distribute operation for all databases.

**TABLE 41** Distribution policy states

Fabric OS	State
v6.2.0 and later configured to accept	Target switch accepts distribution and fabric state change occurs.

**TABLE 41** Distribution policy states (continued)

Fabric OS	State
v6.2.0 and later configured to reject	Target switch explicitly rejects the distribution and the operation fails. The entire transaction is aborted and no fabric state change occurs.

## Device Connection Control policies

Multiple Device Connection Control (DCC) policies can be used to restrict which device ports can connect to which switch ports. The devices can be initiators, targets, or intermediate devices such as SCSI routers and loop hubs. By default, all device ports are allowed to connect to all switch ports; no DCC policies exist until they are created. For information regarding DCC policies and F\_Port trunking, refer to the *Access Gateway Administrator's Guide*.

Each device port can be bound to one or more switch ports; the same device ports and switch ports may be listed in multiple DCC policies. After a switch port is specified in a DCC policy, it permits connections only from designated device ports. Device ports that are not specified in any DCC policies are allowed to connect only to switch ports that are not specified in any DCC policies.

When a DCC violation occurs, the related port is automatically disabled and must be re-enabled using the **portEnable** command.

Table 42 shows the possible DCC policy states.

**TABLE 42** DCC policy states

Policy state	Characteristics
No policy	Any device can connect to any switch port in the fabric.
Policy with no entries	Any device can connect to any switch port in the fabric. An empty policy is the same as no policy.
Policy with entries	<p>If a device WWN or Fabric port WWN is specified in a DCC policy, that device is only allowed access to the switch if connected by a switch port listed in the same policy.</p> <p>If a switch port is specified in a DCC policy, it only permits connections from devices that are listed in the policy.</p> <p>Devices with WWNs that are not specified in a DCC policy are allowed to connect to the switch at any switch ports that are not specified in a DCC policy.</p> <p>Switch ports and device WWNs may exist in multiple DCC policies.</p> <p>Proxy devices are always granted full access and can connect to any switch port in the fabric.</p>

## Virtual Fabrics considerations

The DCC policies that have entries for the ports that are being moved from one logical switch to another will be considered *stale* and will not be enforced. You can choose to keep *stale* policies in the current logical switch or delete the *stale* policies after the port movements. Use the **secPolicyDelete** command to delete stale DCC policies.

## DCC policy restrictions

The following restrictions apply when using DCC policies:

- Some older private-loop host bus adaptors (HBAs) do not respond to port login from the switch and are not enforced by the DCC policy. This does not create a security problem because these HBAs cannot contact any device outside of their immediate loop.

- DCC policies cannot manage or restrict iSCSI connections, that is, an FC Initiator connection from an iSCSI gateway.
- You cannot manage proxy devices with DCC policies. Proxy devices are always granted full access, even if the DCC policy has an entry that restricts or limits access of a proxy device.

## Creating a DCC policy

DCC policies must follow the naming convention "DCC\_POLICY\_*nnn*", where *nnn* represents a unique string. The maximum length is 30 characters, including the prefix DCC\_POLICY\_.

Device ports must be specified by port WWN. Switch ports can be identified by the switch WWN, domain ID, or switch name followed by the port or area number. To specify an allowed connection, enter the device port WWN, a semicolon, and the switch port identification.

The following methods of specifying an allowed connection are possible:

- *deviceportWWN;switchWWN* (port or area number)
  - *deviceportWWN;domainID* (port or area number)
  - *deviceportWWN;switchname* (port or area number)
1. Connect to the switch and log in using an account with admin permissions, or an account with OM permissions for the Security RBAC class of commands.
  2. Enter the **secPolicyCreate** command, specifying the name of the DCC policy.

```
secpolicycreate "DCC_POLICY_nnn
"
```

3. To save or activate the new policy, enter the appropriate command:
  - To save the policy, enter the **secPolicySave** command.
  - To save and activate the policy, enter the **secPolicyActivate** command.

If neither of these commands is entered, the changes are lost when the session is logged out.

## Examples of creating DCC policies

To create the DCC policy "DCC\_POLICY\_server" that includes device 11:22:33:44:55:66:77:aa and port 1 and port 3 of switch domain 1:

```
switch:admin> secpolicycreate "DCC_POLICY_server", "11:22:33:44:55:66:77:aa;1(1,3)"
DCC_POLICY_server
has been created
```

To create the DCC policy "DCC\_POLICY\_storage" that includes device port WWN 22:33:44:55:66:77:11:bb, all ports of switch domain 2, and all currently connected devices of switch domain 2:

```
switch:admin> secpolicycreate "DCC_POLICY_storage", "22:33:44:55:66:77:11:bb;2[*]"
DCC_POLICY_storage
has been created
```

To create the DCC policy "DCC\_POLICY\_abc" that includes device 33:44:55:66:77:11:22:cc and ports 1 through 6 and port 9 of switch domain 3:

```
switch:admin> secpolicycreate "DCC_POLICY_abc", "33:44:55:66:77:11:22:cc;3(1-6,9)"
DCC_POLICY_abc
has been created
```

To create the DCC policy "DCC\_POLICY\_example" that includes devices 44:55:66:77:22:33:44:dd and 33:44:55:66:77:11:22:cc, ports 1 through 4 of switch domain 4, and all devices currently connected to ports 1 through 4 of switch domain 4:

```
switch:admin> secpolicycreate "DCC_POLICY_example", "44:55:66:77:22:33:44:dd;33:44:55:66:77:11:22:cc;4[1-4]"
DCC_POLICY_example
has been created
```

## Deleting a DCC policy

1. Connect to the switch and log in using an account with admin permissions, or an account with OM permissions for the Security RBAC class of commands.
2. Enter the **secPolicyDelete** command.

Example of deleting stale DCC policies

```
switch:admin> secpolicydelete ALL_STALE_DCC_POLICY

About to clear all STALE DCC policies
ARE YOU SURE (yes, y, no, n): [no] y
```

## DCC policy behavior with Fabric-Assigned PWWNs

A DCC policy check is always performed for the physical port WWN of a device when the HBA has established that the device is attempting a normal FLOGI and has both a fabric-assigned port WWN (FA-PWWN) and a physical port WWN.

DCC policies created with FA-PWWNs will result in the disabling of FA-PWWN assigned ports on subsequent FLOGI. It is therefore recommended to create policies with the physical PWWN

DCC policies created with the lock down feature result in DCC policies with FA-PWWNs. It is therefore recommended to avoid using the lock down feature in fabrics that are using FA-PWWNs.

A DCC policy created with a device WWN for a specific port allows the device to log in only on the same port. The same device will not be allowed to log in on a different port. For devices that log in across an AG, the policy should be created with all the NPIV ports, so even if failover occurs the device will be allowed to log in on a different NPIV port.

[Table 43](#) lists the behavior of the DCC policy with FA-PWWNs in the fabric when the DCC policy is created using lockdown support.

**TABLE 43** DCC policy behavior with FA-PWWN when created using lockdown support

Configuration	WWN seen on DCC policy list	Behavior when DCC policy activates	Behavior on portDisable and portEnable
<ul style="list-style-type: none"> <li>FA-PWWN has logged into the switch</li> <li>DCC policy creation with lock down (uses FA-PWWN).</li> <li>DCC policy activation.</li> </ul>	FA-PWWN	Traffic will not be disrupted. <sup>2</sup>	Ports will be disabled for security violation. <sup>3</sup>
<ul style="list-style-type: none"> <li>DCC policy creation with lockdown (uses physical PWWN).</li> <li>FA-PWWN has logged into the switch</li> <li>DCC policy activation.</li> </ul>	Physical PWWN	Traffic will not be disrupted.	Ports will come up without security issues.
<ul style="list-style-type: none"> <li>DCC policy creation with lockdown (uses physical PWWN)</li> <li>DCC policy activation</li> <li>FA-PWWN has logged into the switch</li> </ul>	Physical PWWN	Traffic will not be disrupted.	Ports will come up without any security issues.

Table 44 shows the behavior of a DCC policy created manually with the physical PWWN of a device. The configurations shown in this table are the recommended configurations when an FA-PWWN is logged into the switch.

**TABLE 44** DCC policy behavior when created manually with PWWN

Configuration	WWN seen on DCC policy list	Behavior when DCC policy activates	Behavior on portDisable and portEnable
<ul style="list-style-type: none"> <li>FA-PWWN has logged into the switch.</li> <li>DCC policy creation manually with physical PWWN of device.</li> <li>DCC policy activation.</li> </ul>	PWWN	Traffic will not be disrupted.	Ports will come up without security issues.
<ul style="list-style-type: none"> <li>DCC policy creation manually with physical PWWN</li> <li>FA-PWWN has logged into the switch.</li> <li>DCC policy activation.</li> </ul>	PWWN	Traffic will not be disrupted.	Ports will come up without security issues.
<ul style="list-style-type: none"> <li>DCC policy creation manually with physical PWWN,</li> <li>DCC policy activation.</li> </ul>	Physical PWWN	Traffic will not be disrupted.	Ports will come up without any security issues.

<sup>2</sup> Indicates a security concern, because devices that are logged in with FA-PWWNs will not be disabled after activation of DCC policies that are created with FA-PWWNs. This is done to avoid disturbing any existing management.

<sup>3</sup> Any disruption in the port will disable the port for a security violation. As the traffic is already disrupted for this port, you must enforce the DCC policy for a physical device WWN; otherwise, the device will not be allowed to login again.

**TABLE 44** DCC policy behavior when created manually with PWWN (continued)

Configuration	WWN seen on DCC policy list	Behavior when DCC policy activates	Behavior on portDisable and portEnable
<ul style="list-style-type: none"> <li>FA-PWWN has logged into the switch.</li> </ul>			

## SCC Policies

The switch connection control (SCC) policy is used to restrict which switches can join the fabric. Switches are checked against the policy each time an E\_Port-to-E\_Port connection is made. The policy is named SCC\_POLICY and accepts members listed as WWNs, domain IDs, or switch names. Only one SCC policy can be created.

By default, any switch is allowed to join the fabric; the SCC policy does not exist until it is created. When connecting a Fibre Channel router to a fabric or switch that has an active SCC policy, the front domain of the Fibre Channel router must be included in the SCC policy.

SCC policy states are shown in [Table 45](#).

**TABLE 45** SCC policy states

Policy state	SCC policy enforcement
No active policy	All switches can connect to the switch with the specified policy.
Active policy that has no members	All neighboring switches are segmented.
Active policy that has members	The neighboring switches not specified in the SCC policy are segmented.

## Virtual Fabrics considerations for SCC policies

In a logical fabric environment the SCC policy enforcement is not done on the logical ISL. For a logical ISL-based switch, the SCC policy enforcement is considered as the reference and the logical ISL is formed if the SCC enforcement passes on the extended ISL. The following changes:

- A logical switch supports an SCC policy. You can configure and distribute an SCC policy on a logical switch.
- SCC enforcement is performed on a ISL based on the SCC policy present on the logical switch.

For more information on Virtual Fabrics, refer to [Managing Virtual Fabrics](#) on page 267.

## Creating an SCC policy

- Connect to the switch and log in using an account with admin permissions, or an account with OM permissions for the Security RBAC class of commands.
- Enter the **secPolicyCreate "SCC\_POLICY"** command.
- Save or activate the new policy by entering either the **secPolicySave** or the **secPolicyActivate** command.

If neither of these commands is entered, the changes are lost when the session is logged out.

Example of creating an SCC policy

For example, to create an SCC policy that allows switches that have domain IDs 2 and 4 to join the fabric:

```
switch:admin> secpolicycreate "SCC_POLICY", "2;4"
SCC_POLICY has been created
switch:admin> secpolicysave
```

## Authentication policy for fabric elements

By default, Fabric OS v6.2.0 and later use Diffie Hellman - Challenge Handshake Authentication Protocol (DH-CHAP) or Fibre Channel Authentication Protocol (FCAP) for authentication.

These protocols use shared secrets and digital certificates, based on switch WWN and public key infrastructure (PKI) technology, to authenticate switches. Authentication automatically defaults to FCAP if both switches are configured to accept FCAP protocol in authentication, unless ports are configured for in-flight encryption, in which case authentication defaults to DH-CHAP if both switches are configured to accept the DH-CHAP protocol in authentication. To use FCAP on both switches, PKI certificates have to be installed.

The DH-CHAP and FCAP authentication protocols used by Brocade switches are FC-SP2 standard compliant.

### NOTE

The fabric authentication feature is available in base Fabric OS. No license is required.

FCAP requires the exchange of certificates between two or more switches to authenticate to each other before they form or join a fabric. Beginning with Fabric OS v7.0.0, these certificates are no longer issued by Brocade, but by a third-party which is now the root CA for all of the issued certificates. You can use Brocade and third-party certificates between switches that are Fabric OS v6.4.0, but only Brocade-issued certificates (where Brocade is the root CA) for Fabric OS versions earlier than v6.4.0. The certificates must be in PEM (Privacy Enhanced Mail) encoded format for both root and peer certificates. The switch certificates issued from the third-party vendors can be directly issued from the root CA or from an intermediate CA authority.

When you configure DH-CHAP authentication, you also must define a *pair of shared secrets* known to both switches as a *secret key pair*. Figure 13 illustrates how the secrets are configured. A *secret key pair* consists of a local secret and a peer secret. The local secret uniquely identifies the local switch. The peer secret uniquely identifies the entity to which the local switch authenticates. Every switch can share a *secret key pair* with any other switch or host in a fabric.

To use DH-CHAP authentication, a *secret key pair* has to be configured on both switches. For more information on setting up secret key pairs, refer to [Setting a secret key pair](#) on page 233.

When configured, the *secret key pair* is used for authentication. Authentication occurs whenever there is a state change for the switch or port. The state change can be due to a switch reboot, a switch or port disable and enable, or the activation of a policy.

FIGURE 13 DH-CHAP authentication



If you use DH-CHAP authentication, then a *secret key pair* must be installed only in connected fabric elements. However, as connections are changed, new *secret key pairs* must be installed between newly connected elements. Alternatively, a *secret key pair* for all possible connections may be initially installed, enabling links to be arbitrarily changed while still maintaining a valid *secret key pair* for any new connection.

The switch authentication (AUTH) policy initiates DH-CHAP/FCAP authentication on all E\_Ports. This policy is persistent across reboots, which means authentication will be initiated automatically on ports or switches brought online if the policy is set to activate authentication. The AUTH policy is distributed by command; automatic distribution of the AUTH policy is not supported.

The default configuration directs the switch to attempt FCAP authentication first, DH-CHAP second. The switch may be configured to negotiate FCAP, DH-CHAP, or both.

The DH group is used in the DH-CHAP protocol only. The FCAP protocol exchanges the DH group information, but does not use it.

## Virtual Fabrics considerations

If Virtual Fabrics is enabled, all AUTH module parameters such as shared secrets, and shared switch and device policies, are logical switch-wide. That means you must configure shared secrets and policies separately on each logical switch and the shared secrets and policies must be set on each switch prior to authentication. On logical switch creation, authentication takes default values for policies and other parameters. FCAP certificates are installed on a chassis, but are configured on each logical switch.

## E\_Port authentication

The authentication (AUTH) policy allows you to configure DH-CHAP authentication on switches with Fabric OS v5.3.0 and later. By default the policy is set to PASSIVE and you can change the policy. All changes to the AUTH policy take effect during the next authentication request. This includes starting authentication on all E\_Ports on the local switch if the policy is changed to ON or ACTIVE, and clearing the authentication if the policy is changed to OFF. The authentication configurations will be effective only on subsequent E\_ and F\_Port initialization.

### ATTENTION

A *secret key pair* has to be installed prior to changing the policy. For more information on setting up secret key pairs, refer to [Setting a secret key pair](#) on page 233.

If you must disable authentication on a port that has in-flight encryption or compression configured, you must first disable in-flight encryption or compression on the port, and then disable authentication.

## Virtual Fabrics considerations

The switch authentication policy applies to all E\_Ports in a logical switch. This includes ISLs and extended ISLs. Authentication of extended ISLs between two base switches is considered peer-chassis authentication. Authentication between two physical entities is required, so the extended ISL which connects the two chassis needs to be authenticated. The corresponding extended ISL for a logical ISL authenticates the peer-chassis, therefore the logical ISL authentication is not required. Because the logical ISLs do not carry actual traffic, they do not need to be authenticated. Authentication on re-individualization is also blocked on logical ISLs. The following error message is printed on the console when you execute the `authUtil --authinit` command on logical-ISLs, "Failed to initiate authentication. Authentication is not supported on logical ports <port#>". For more information on Virtual Fabrics, refer to [Virtual Fabrics considerations](#).

## Configuring E\_Port authentication

1. Connect to the switch and log in using an account with admin permissions, or an account with OM permissions for the Authentication RBAC class of commands.
2. Enter the `authUtil` command to set the switch policy mode.



### Example of configuring E\_Port authentication

The following example shows how to enable Virtual Fabrics and configure the E\_Ports to perform authentication using the AUTH policies **authUtil** command.

```
switch:admin> fosconfig -enable vf
WARNING: This is a disruptive operation that requires a reboot to take effect.
All EX ports will be disabled upon reboot.
Would you like to continue [Y/N] y
switch:admin> authutil --authinit 2,3,4
```



#### CAUTION

If data input has not been completed and a failover occurs, the command is terminated without completion and your entire input is lost. If data input has completed, the enter key pressed, and a failover occurs, data may or may not be replicated to the other CP depending on the timing of the failover. Log in to the other CP after the failover is complete and verify the data was saved. If data was not saved, run the command again.

### Example of setting the policy to active mode

```
switch:admin> authutil --policy -sw active
Warning: Activating the authentication policy requires
either DH-CHAP secrets or PKI certificates depending
on the protocol selected. Otherwise, ISLs will be
segmented during next E-port bring-up.
ARE YOU SURE (yes, y, no, n): [no] y
Auth Policy is set to ACTIVE
```

#### NOTE

This authentication-policy change will not affect online EX\_Ports.

### Re-authenticating E\_Ports

Use the **authUtil --authinit** command to re-initiate the authentication on selected ports. It provides flexibility to initiate authentication for specified E\_Ports, a set of E\_Ports, or all E\_Ports on the switch. This command does not work on loop, NPIV and FICON devices, or on ports configured for in-flight encryption. The command **authUtil** can re-initiate authentication only if the device was previously authenticated. If the authentication fails because shared secrets do not match, the port is disabled.

This command works independently of the authentication policy; this means you can initiate the authentication even if the switch is in PASSIVE mode. This command is used to restart authentication after changing the DH-CHAP group, hash type, or shared secret between a pair of switches.

#### ATTENTION

This command may bring down E\_Ports if the DH-CHAP shared secrets are not installed correctly.

1. Log in to the switch using an account with admin permissions, or an account with OM permissions for the Authentication RBAC class of commands.
2. Enter the **authUtil --authinit** command.

### Example for specific ports on the switch

```
switch:admin> authutil --authinit 2,3,4
```

### Example for all E\_Ports on the switch

```
switch:admin> authutil --authinit allE
```

### Example for Backbones using the slot/port format

```
switch:admin> authutil --authinit 1/1, 1/2
```

## Device authentication policy

Device authentication policy can also be categorized as an F\_Port, node port, or an HBA authentication policy. Fabric-wide distribution of the device authentication policy is not supported because the device authentication requires manual interaction in setting the HBA shared secrets and switch shared secrets, and most of the HBAs do not support the defined DH groups for use in the DH-CHAP protocol.

### NOTE

Authentication is supported from Brocade fabric switches in native mode to Access Gateway switches and from Access Gateway switches to HBAs. For more information, refer to the *Access Gateway Administrator's Guide*.

By default the devicepolicy is in the OFF state, which means the switch clears the security bit in the FLOGI (fabric login). The **authUtil** command provides an option to change the device policy mode to select PASSIVE policy, which means the switch responds to authentication from any device and does not initiate authentication to devices.

When the policy is set to ON, the switch expects a FLOGI with the FC-SP bit set. If not, the switch rejects the FLOGI with reason LS\_LOGICAL\_ERROR (0x03), explanation "Authentication Required"(0x48), and disables the port. Regardless of the policy, the F\_Port is disabled if the DH-CHAP protocol fails to authenticate.

If the HBA sets the FC-SP bit during FLOGI and the switch sends a FLOGI accept with the FC-SP bit set, then the switch expects the HBA to start the AUTH\_NEGOTIATE. From this point on until the AUTH\_NEGOTIATE is completed, all ELS and CT frames, except the AUTH\_NEGOTIATE ELS frame, are blocked by the switch. During this time, the Fibre Channel driver rejects all other ELS frames. The F\_Port does not form until the AUTH\_NEGOTIATE is completed. It is the HBA's responsibility to send an Authentication Negotiation ELS frame after receiving the FLOGI accept frame with the FC-SP bit set.

## Virtual Fabrics considerations

Because the device authentication policy has switch and logical switch-based parameters, each logical switch is set when Virtual Fabrics is enabled. Authentication is enforced based on each logical switch's policy settings.

## Configuring device authentication

1. Connect to the switch and log in using an account with admin permissions, or an account with OM permissions for the Authentication RBAC class of commands.
2. Enter the **authUtil** command to set the device policy mode.

### Example of setting the Device policy to passive mode

```
switch:admin> authutil --policy -dev passive
Warning: Activating the authentication policy requires
DH-CHAP secrets on both switch and device. Otherwise,
the F-port will be disabled during next F-port
bring-up.
ARE YOU SURE (yes, y, no, n): [no] y
Device authentication is set to PASSIVE
```

## AUTH policy restrictions

All fabric element authentication configurations are performed on a local switch basis.

Device authentication policy supports devices that are connected to the switch in point-to-point manner and is visible to the entire fabric. The following are not supported:

- Public loop devices
- Single private devices

- Private loop devices
- Mixed public and private devices in loop
- NPIV devices
- FICON channels
- Configupload and download will not be supported for the following AUTH attributes: auth type, hash type, group type.

**NOTE**

For information about how to use authentication with Access Gateway, refer to the *Access Gateway Administrator's Guide*.

## Authentication protocols

Use the **authUtil** command to perform the following tasks:

- Display the current authentication parameters.
- Select the authentication protocol used between switches.
- Select the DH (Diffie-Hellman) group for a switch.

Run the **authUtil** command on the switch you want to view or change. Below are the different options to specify which DH group you want to use.

- 00 - DH Null option
- 01 - 1024 bit key
- 02 - 1280 bit key
- 03 - 1536 bit key
- 04 - 2048 bit key

## Viewing the current authentication parameter settings for a switch

1. Log in to the switch using an account with admin permissions, or an account with the O permission for the Authentication RBAC class of commands.
2. Enter the **authUtil --show** command.

Example of output from the **authUtil-- show** command

```

AUTH TYPE          HASH TYPE          GROUP TYPE
-----
fcap,dhchap        sha1,md5           0, 1, 2, 3, 4
Switch Authentication Policy: PASSIVE
Device Authentication Policy: OFF

```

## Setting the authentication protocol

1. Log in to the switch using an account with admin permissions, or an account with OM permissions for the Authentication RBAC class of commands.
2. Enter the **authUtil --set -a** command specifying **fcap**, **dhchap**, or **all**.

Example of setting the DH-CHAP authentication protocol

```

switch:admin> authutil --set -a dhchap
Authentication is set to dhchap.

```

When using DH-CHAP, make sure that you configure the switches at both ends of a link.

**NOTE**

When you set the authentication protocol to FCAP, ensure that the certificates are present at both ends.

**NOTE**

If you set the authentication protocol to DH-CHAP or FCAP, have not configured shared secrets or certificates, and authentication is checked (for example, you enable the switch), then switch authentication will fail. If the E\_Port is to carry in-flight encrypted traffic, the authentication protocol must be set to DH-CHAP. You must also use the **-g** option to set the DH group value to group 4 or all groups.

```
switch# authutil --set -g *
```

OR

```
switch# authutil --set -g 4
```

## Secret key pairs for DH-CHAP

When you configure the switches at both ends of a link to use DH-CHAP for authentication, you must also define a *secret key pair* **--one** for each end of the link. Use the **secAuthSecret** command to perform the following tasks:

- View the WWN of switches with a *secret key pair*
- Set the *secret key pair* for switches.
- Remove the *secret key pair* for one or more switches.

**NOTE**

The DH-CHAP secrets are stored using AES-256 encryption.

## Characteristics of a secret key pair

- The *secret key pair* must be set up locally on every switch. The *secret key pair* is not distributed fabric-wide.
- If a *secret key pair* is not set up for a link, authentication fails. The "Authentication Failed" (reason code 05h) error will be reported and logged.
- The minimum length of a shared secret is 8 characters and the maximum length is 40 characters. If the E\_Port is to carry in-flight encrypted traffic, a shared secret or at least 32 characters is recommended.

**NOTE**

When setting a *secret key pair*, note that you are entering the shared secrets in plain text. Use a secure channel (for example, SSH or the serial console) to connect to the switch on which you are setting the secrets.

## Viewing the list of secret key pairs in the current switch database

1. Log in to the switch using an account with admin permissions, or an account with the O permission for the Authentication RBAC class of commands.
2. Enter the **secAuthSecret --show** command.

The output displays the WWN, domain ID, and name (if known) of the switches with defined shared secrets:

WWN	DIId	Name
10:00:00:60:69:80:07:52		Unknown
10:00:00:60:69:80:07:5c	1	switchA

### Note about Access Gateway switches

Because Domain ID and name are not supported for Access Gateway, **secAuthSecret --show** output for Access Gateway appears as follows:

WWN	DId	Name
10:00:8C:7C:FF:03:9E:00	-1	Unknown
10:00:8C:7C:FF:03:9E:01	-1	Unknown
10:00:8C:7C:FF:0D:AF:01	-1	Unknown

When setting and removing the secret for a switch or device on Access Gateway, only the WWN can be used.

### Setting a secret key pair

1. Log in to the switch using an account with admin permissions, or an account with OM permissions for the Authentication RBAC class of commands.
2. Enter the **secAuthSecret --set** command.

The command enters interactive mode. The command returns a description of itself and needed input; then it loops through a sequence of switch specification, peer secret entry, and local secret entry.

To exit the loop, press **Enter** for the switch name; then type **y**.

Example of setting a secret key pair

```
switchA:admin> secauthsecret --set
This command is used to set up secret keys for the DH-CHAP authentication.
The minimum length of a secret key is 8 characters and maximum 40
characters. Setting up secret keys does not initiate DH-CHAP
authentication. If switch is configured to do DH-CHAP, it is performed
whenever a port or a switch is enabled.
Warning: Please use a secure channel for setting secrets. Using
an insecure channel is not safe and may compromise secrets.
Following inputs should be specified for each entry.
1. WWN for which secret is being set up.
2. Peer secret: The secret of the peer that authenticates to peer.
3. Local secret: The local secret that authenticates peer.
Press Enter to start setting up shared secrets > <cr>
Enter WWN, Domain, or switch name (Leave blank when done): 10:20:30:40:50:60:70:80
Enter peer secret: <hidden>
Re-enter peer secret: <hidden>
Enter local secret: <hidden>
Re-enter local secret: <hidden>
Enter WWN, Domain, or switch name (Leave blank when done): 10:20:30:40:50:60:70:81
Enter peer secret: <hidden>
Re-enter peer secret: <hidden>
Enter local secret: <hidden>
Re-enter local secret: <hidden>
Enter WWN, Domain, or switch name (Leave blank when done): <cr>
Are you done? (yes, y, no, n): [no] y
Saving data to key store... Done.
```

3. Disable and enable the ports on a peer switch using the **portDisable** and **portEnable** commands.

### FCAP configuration overview

Beginning with Fabric OS release 7.0.0, you must configure the switch to use third-party certificates for authentication with the peer switch.

To perform authentication with FCAP protocol with certificates issued from third party, the user has to perform following steps:

1. Choose a certificate authority (CA).
2. Generate a public, private key, passphrase and a CSR on each switch.

3. Store the CSR from each switch on a file server.
4. Obtain the certificates from the CA.

You can request a certificate from a CA through a Web browser. After you request a certificate, the CA either sends certificate files by e-mail (public) or gives access to them on a remote host (private). Typically, the CA provides the certificate files listed in the following table.

#### ATTENTION

Only the .pem file is supported for FCAP authentication.

Certificate File	Description
name CA.pem	The CA certificate. It must be installed on the remote and local switch to verify the validity of the switch certificate or switch validation fails.
name .pem	The switch certificates:switch certificate.

5. On each switch, install the CA certificate before installing switch certificate.
6. After the CA certificate is installed, install the switch certificate on each switch.
7. Update the switch database for peer switches to use third-party certificates.
8. Use the newly installed certificates by starting the authentication process.

## Generating the key and CSR for FCAP

The public/private key and CSR has to be generated for the local and remote switches that will participate in the authentication. In FCAP, one command is used to generate the public/private key the CSR, and the passphrase.

1. Log in to the switch using an account with admin permissions, or an account associated with the chassis role and having OM permissions for the PKI RBAC class of commands.
2. Enter the **secCertUtil generate -fcap -keysize** command on the local switch.

```
switch:admin> seccertutil generate -fcap -keysize 1024 -hash sha1|sha256
WARNING!!!
About to create FCAP:
ARE YOU SURE (yes, y, no, n): [no] y
Installing Private Key and Csr...
Switch key pair and CSR generated...
```

3. Repeat step 2 on the remote switch.

## Exporting the CSR for FCAP

You will need to export the CSR file created in [Generating the key and CSR for FCAP](#) on page 234 section and send to a Certificate Authority (CA). The CA will in turn provide two files as outlined in [FCAP configuration overview](#) on page 233.

1. Log in to the switch using an account with admin permissions, or an account associated with the chassis role and having OM permissions for the PKI RBAC class of commands.
2. Enter the **secCertUtil export -fcapswcsr** command.

```
switch:admin> seccertutil export -fcapswcsr
Select protocol [ftp or scp]: scp
Enter IP address: 10.1.2.3
Enter remote directory: /myHome/jdoe/OPENSSL
Enter Login Name: jdoe
jdoe@10.1.2.3's password: <hidden text>
Success: exported FCAP CA certificate
```

## Importing CA for FCAP

Once you receive the files back from the Certificate Authority, you will need to install or import them onto the local and remote switches.

1. Log in to the switch using an account with admin permissions, or an account associated with the chassis role and having OM permissions for the PKI RBAC class of commands.
2. Enter the **secCertUtil import -fcapcert** command and verify the CA certificates are consistent on both local and remote switches.

```
switch:admin> seccertutil import -fcapcert
Select protocol [ftp or scp]: scp
Enter IP address: 10.1.2.3
Enter remote directory: /myHome/jdoe/OPENSSL
Enter certificate name (must have a ".pem" suffix):CACert.pem
Enter Login Name: jdoe
jdoe@10.1.2.3's password: <hidden text>
Success: imported certificate [CACert.pem].
```

### NOTE

Firmware downgrade from Fabric OS 7.3.0 to an earlier version is blocked if SHA-256 is one of the configured hash types for DH-CHAP or FCAP in at least one of the logical switches.

## Importing the FCAP switch certificate

### ATTENTION

The CA certificates must be installed prior to installing the switch certificate.

1. Log in to the switch using an account with admin permissions, or an account associated with the chassis role and having OM permissions for the PKI RBAC class of commands.
2. Enter the **secCertUtil import -fcapswcert** command.

```
switch:admin> seccertutil import -fcapswcert
Select protocol [ftp or scp]: scp
Enter IP address: 10.1.2.3
Enter remote directory: /myHome/jdoe/OPENSSL
Enter certificate name (must have ".crt" or ".cer" ".pem" or ".psk" suffix):01.pem
Enter Login Name: jdoe
jdoe@10.1.2.3's password: <hidden text>
Success: imported certificate [01.pem].
```

## Starting FCAP authentication

1. Log in to the switch using an account with admin permissions, or an account with OM permissions for the Authentication RBAC class of commands.
2. Enter the **authUtil --authinit** command to start the authentication using the newly imported certificates. (This command is not supported in Access Gateway mode.)
3. Enter the **authUtil --policy -sw** command with either the **active** or **on** option.

```
authutil --policy -sw active
```

This makes the changes permanent and forces the switch to request authentication. (For Access Gateway mode, the defaults for sw policy and dev policy are **off**, and there is no **passive** option for sw policy.)

### NOTE

This authentication-policy change does not affect online EX\_Ports.

## Fabric-wide distribution of the authorization policy

The AUTH policy can be manually distributed to the fabric by command; there is no support for automatic distribution. To distribute the AUTH policy, see [Distributing the local ACL policies](#) on page 244 for instructions.

Local Switch configuration parameters are needed to control whether a switch accepts or rejects distributions of the AUTH policy using the distribute command and whether the switch may initiate distribution of the policy. To set the local switch configuration parameter, refer to [Policy database distribution](#) on page 242.

### NOTE

This is not supported for Access Gateway mode.

## IP Filter policy

The IP Filter policy is a set of rules applied to the IP management interfaces as a packet filtering firewall. The firewall permits or denies the traffic to go through the IP management interfaces according to the policy rules.

Fabric OS supports multiple IP Filter policies to be defined at the same time. Each IP Filter policy is identified by a name and has an associated type. Two IP Filter policy types, IPv4 and IPv6, exist to provide separate packet filtering for IPv4 and IPv6. It is not allowed to specify an IPv6 address in the IPv4 filter, or specify an IPv4 address in the IPv6 filter. There can be up to six different IP Filter policies defined for both types. Only one IP Filter policy for each IP type can be activated on the affected management IP interfaces.

Audit messages will be generated for any changes to the IP Filter policies.

The rules in the IP Filter policy are examined one at a time until the end of the list of rules. For performance reasons, the most commonly used rules should be specified at the top.

On a chassis system, changes to persistent IP Filter policies are automatically synchronized to the standby CP when the changes are saved persistently on the active CP. The standby CP will enforce the filter policies to its management interface after policies are synchronized with the active CP.

## Virtual Fabrics considerations for IP Filter policy

Each logical switch cannot have its own different IP Filter policies. IP Filter policies are treated as a chassis-wide configuration and are common for all the logical switches in the chassis.

## Creating an IP Filter policy

You can create an IP Filter policy specifying any name and using type IPv4 or IPv6. The policy created is stored in a temporary buffer, and is lost if the current command session logs out. The policy name is a unique string composed of a maximum of 20 alpha, numeric, and underscore characters. The names "*default\_ipv4*" and "*default\_ipv6*" are reserved for default IP filter policies. The policy name is case-insensitive and always stored as lowercase. The policy type identifies the policy as an IPv4 or IPv6 filter. There can be a maximum of six IP Filter policies.

1. Log in to the switch using an account with admin permissions, or an account associated with the chassis role and having OM permissions for the IPfilter RBAC class of commands.
2. Enter in the `ipFilter --create` command.

## Cloning an IP Filter policy

You can create an IP Filter policy as an exact copy of an existing policy. The policy created is stored in a temporary buffer and has the same type and rules as the existing defined or active policy.



1. Log in to the switch using an account with admin permissions, or an account associated with the chassis role and having OM permissions for the IPfilter RBAC class of commands.
2. Enter the **ipFilter --clone** command.

## Displaying an IP Filter policy

You can display the IP Filter policy content for the specified policy name, or all IP Filter policies if a policy name is not specified.

For each IP Filter policy, the policy name, type, persistent state and policy rules are displayed. The policy rules are listed by the rule number in ascending order. There is no pagination stop for multiple screens of information. Pipe the output to the **|more** command to achieve this.

If a temporary buffer exists for an IP Filter policy, the **--show** subcommand displays the content in the temporary buffer, with the persistent state set to no.

1. Log in to the switch using an account with admin permissions, or an account associated with the chassis role and having the O permission for the IPfilter RBAC class of commands.
2. Enter the **ipFilter --show** command.

## Saving an IP Filter policy

You can save one or all IP Filter policies persistently in the defined configuration.

Only the CLI session that owns the updated temporary buffer may run this command. Modification to an active policy cannot be saved without being applied. Hence, the **--save** subcommand is blocked for the active policies. Use **--activate** instead.

1. Log in to the switch using an account with admin permissions, or an account associated with the chassis role and having the OM permissions for the IPfilter RBAC class of commands.
2. Enter the **ipFilter --save** command.

## Activating an IP Filter policy

IP Filter policies are not enforced until they are activated. Only one IP Filter policy per IPv4 and IPv6 type can be active. If there is a temporary buffer for the policy, the policy is saved to the defined configuration and activated at the same time. If there is no temporary buffer for the policy, the policy existing in the defined configuration becomes active. The activated policy continues to remain in the defined configuration. The policy to be activated replaces the existing active policy of the same type. Activating the default IP Filter policies returns the IP management interface to its default state. An IP Filter policy without any rule cannot be activated. This subcommand prompts for a user confirmation before proceeding.

1. Log in to the switch using an account with admin permissions, or an account associated with the chassis role and having OM permissions for the IPfilter RBAC class of commands.
2. Enter the **ipFilter --activate** command.

## Deleting an IP Filter policy

You can delete a specified IP Filter policy. Deleting an IP Filter policy removes it from the temporary buffer. To permanently delete the policy from the persistent database, run **ipfilter --save**. An active IP Filter policy cannot be deleted.

1. Log in to the switch using an account with admin permissions, or an account associated with the chassis role and having the OM permissions for the IPfilter RBAC class of commands.
2. Enter the **ipFilter --delete** command.

- To permanently delete the policy, enter the `ipfilter --save` command.

## IP Filter policy rules

An IP Filter policy consists of a set of rules. Each rule has an index number identifying the rule. There can be a maximum of 256 rules within an IP Filter policy.

Each rule contains the following elements:

- Source Address: A source IP address or a group prefix.
- Destination Port: The destination port number or name, such as: Telnet, SSH, HTTP, HTTPS.
- Protocol: The protocol type. Supported types are TCP or UDP.
- Action: The filtering action taken by this rule, either Permit or Deny.

A traffic type and destination IP can also be specified

### Source address

For an IPv4 filter policy, the source address has to be a 32-bit IPv4 address in dot decimal notation. The group prefix has to be a CIDR block prefix representation. For example, `208.130.32.0/24` represents a 24-bit IPv4 prefix starting from the most significant bit. The special prefix `0.0.0.0/0` matches any IPv4 address. In addition, the keyword **any** is supported to represent any IPv4 address.

For an IPv6 filter policy, the source address has to be a 128-bit IPv6 address, in a format acceptable in RFC 3513. The group prefix has to be a CIDR block prefix representation. For example, `12AB:0:0:CD30::/64` represents a 64-bit IPv6 prefix starting from the most significant bit. In addition, the keyword **any** is supported to represent any IPv6 address.

### Destination port

For the destination port, a single port number or a port number range can be specified. According to IANA ( <http://www.iana.org> ), ports 0 to 1023 are well-known port numbers, ports 1024 to 49151 are registered port numbers, and ports 49152 to 65535 are dynamic or private port numbers. Well-known and registered ports are normally used by servers to accept connections, while dynamic port numbers are used by clients.

For an IP Filter policy rule, you can only select port numbers in the well-known port number range, between 0 and 1023, inclusive. This means that you have the ability to control how to expose the management services hosted on a switch, but not the ability to affect the management traffic that is initiated from a switch. A valid port number range is represented by a dash, for example 7-30. Alternatively, service names can also be used instead of port number. [Table 46](#) lists the supported service names and their corresponding port numbers.

**TABLE 46** Supported services

Service name	Port number
echo	7
discard	
systat	11
daytime	13
netstat	15
chargen	19
ftp data	20
ftp	21
fsp	21

**TABLE 46** Supported services (continued)

Service name	Port number
ssh	22
telnet	23
smtp	25
time	27
name	42
whois	43
domain	53
bootps	67
bootpc	68
tftp	69
http	80
kerberos	88
hostnames	101
sftp	115
ntp	123
snmp	161
snmp trap	162
https	443
ssmtp	465
exec	512
login	513
shell	514
uucp	540
biff	512
who	513
syslog	514
route	520
timed	525
kerberos4	750

## Protocol

TCP and UDP protocols are valid protocol selections. Fabric OS v6.2.0 and later do not support configuration to filter other protocols. Implicitly, ICMP type 0 and type 8 packets are always allowed to support ICMP echo request and reply on commands like ping and traceroute.

## Action

For the action, only "permit" and "deny" are valid.

## Traffic type and destination IP

The traffic type and destination IP elements allow an IP policy rule to specify filter enforcement for IP forwarding. The INPUT traffic type is the default and restricts rules to manage traffic on IP management interfaces.

The FORWARD traffic type allows management of bidirectional traffic between the external management interface and the inband management interface. In this case, the destination IP element should also be specified.

## Implicit filter rules

For every IP Filter policy, the two rules listed in [Table 47](#) are always assumed to be appended implicitly to the end of the policy. This ensures that TCP and UDP traffic to dynamic port ranges is allowed, so that management IP traffic initiated from a switch, such as syslog, radius and ftp, is not affected.

**TABLE 47** Implicit IP Filter rules

Source address	Destination port	Protocol	Action
Any	1024-65535	TCP	Permit
Any	1024-65535	UDP	Permit

## Default policy rules

Switches have a default IP Filter policy for IPv4 and IPv6. The default IP Filter policy cannot be deleted or changed. When an alternative IP Filter policy is activated, the default IP Filter policy becomes deactivated. [Table 48](#) lists the rules of the default IP Filter policy.

**TABLE 48** Default IP policy rules

Rule number	Source address	Destination port	Protocol	Action
1	Any	22	TCP	Permit
2	Any	23	TCP	Permit
6	Any	80	TCP	Permit
3	Any	443	TCP	Permit
4	Any	161	UDP	Permit
10	Any	123	UDP	Permit
11 <sup>4</sup>	Any	600-1023	TCP	Permit
12 <sup>4</sup>	Any	600-1023	UDP	Permit

## IP Filter policy enforcement

An active IP Filter policy is a filter applied to the IP packets through the management interface. IPv4 management traffic passes through the active IPv4 filter policy, and IPv6 management traffic passes through the active IPv6 filter policy. The IP Filter policy applies to the incoming (ingress) management traffic only. When a packet arrives, it is compared against each rule, starting from the first rule. If a match is found for the source address, destination port, and protocol, the corresponding action for this rule is taken, and the subsequent rules in this policy are ignored. If there is no match, then it is compared to the next rule in the policy. This process continues until the incoming packet is compared to all rules in the active policy.

If none of the rules in the policy matches the incoming packet, the two implicit rules are matched to the incoming packet. If the rules still do not match the packet, the default action, which is to deny, is taken.

When the IPv4 or IPv6 address for the management interface of a switch is changed through the `ipAddrSet` command or manageability tools, the active IP Filter policies automatically become enforced on the management IP interface with the changed IP address.

<sup>4</sup> None of the RPC ports are configurable, even though the action shows "Permit".

**NOTE**

If a switch is part of a LAN behind a Network Address Translation (NAT) server, depending on the NAT server configuration, the source address in an IP Filter rule may have to be the NAT server address.

## Adding a rule to an IP Filter policy

There can be a maximum of 256 rules created for an IP Filter policy. The change to the specified IP Filter policy is not saved to the persistent configuration until a save or activate subcommand is run.

1. Log in to the switch using an account with admin permissions, or an account associated with the chassis role and having the OM permissions for the IPfilter RBAC class of commands.
2. Enter the **ipFilter --addrule** command.

## Deleting a rule from an IP Filter policy

Deleting a rule in the specified IP Filter policy causes the rules following the deleted rule to shift up in rule order. The change to the specified IP Filter policy is not saved to persistent configuration until a save or activate subcommand is run.

1. Log in to the switch using an account with admin permissions, or an account associated with the chassis role and having the OM permissions for the IPfilter RBAC class of commands.
2. Enter the **ipFilter --delrule** command.

## Aborting an IP Filter transaction

A transaction is associated with a command line or manageability session. It is opened implicitly when the **--create**, **--addrule**, **--delrule**, **--clone**, and **--delete** subcommands are run. The **--transabort**, **--save**, or **--activate** subcommands explicitly end the transaction owned by the current command line or manageability session. If a transaction is not ended, other command line or manageability sessions are blocked on the subcommands that would open a new transaction.

1. Log in to the switch using an account with admin permissions, or an account associated with the chassis role and having the OM permissions for the IPfilter RBAC class of commands.
2. Enter the **ipFilter --transabort** command.

## IP Filter policy distribution

The IP Filter policy is manually distributed by command. The distribution includes both active and defined IP Filter policies. All policies are combined as a single entity to be distributed and cannot be selectively distributed. However, you may choose the time at which to implement the policy for optimization purposes. If a distribution includes an active IP Filter policy, the receiving switches activate the same IP Filter policy automatically. When a switch receives IP Filter policies, all uncommitted changes left in its local transaction buffer are lost, and the transaction is aborted.

The IP Filter policy can be manually distributed to the fabric by command; there is no support for automatic distribution. To distribute the IPFilter policy, see [Distributing the local ACL policies](#) on page 244 for instructions.

You can accept or deny IP Filter policy distribution through the commands **fddCfg --localaccept** or **fddCfg --localreject**. See [Policy database distribution](#) on page 242 for more information on distributing the IP Filter policy.

**NOTE**

Any RPC ports that were allowed in Fabric OS versions earlier than 7.2.0 are removed and ignored in Fabric OS 7.2.0 and later.

**Virtual Fabrics considerations** : To distribute the IP Filter policy in a logical fabric, use the **chassisDistribute** command.

## Policy database distribution

Fabric OS lets you manage and enforce the ACL policy database on either a per-switch or fabric-wide basis. The local switch distribution setting and the fabric-wide consistency policy affect the switch ACL policy database and related distribution behavior.

The ACL policy database is managed as follows:

- **Switch database distribution setting** -- Controls whether or not the switch accepts or rejects databases distributed from other switches in the fabric. The **distribute** command sends the database from one switch to another, overwriting the target switch database with the distributed one. To send or receive a database the setting must be `accept`. For configuration instructions, refer to [Fabric OS v6.2.0 Configuration Guide](#).

**Virtual Fabric considerations:** FCS, DCC, SCC, and AUTH databases can be distributed using the **-distribute** command, but the PWD is blocked from distribution. The IPFILTER databases can be distributed using the FID in VF environment.

- **Manually distribute an ACL policy database** -- Use the **distribute** command to push the local database of the specified policy type to target switches. Refer to [ACL policy distribution to other switches](#) on page 244.
- **Fabric-wide consistency policy** -- Use this policy to ensure that switches in the fabric enforce the same policies. Set a strict or tolerant fabric-wide consistency policy for each ACL policy type to automatically distribute that database when a policy change is activated. If a fabric-wide consistency policy is not set, then the policies are managed on a per-switch basis. For configuration instructions, refer to [Fabric-wide enforcement](#) on page 244.

**Virtual Fabric considerations:** Fabric-wide consistency policies are configured on a per-logical switch basis and are applied to the fabrics connected to the logical switches. Automatic policy distribution behavior for DCC, SCC, and FCS is the same as that of pre-v6.2.0 releases and are configured on a per-logical switch basis.

The following table explains how the local database distribution settings and the fabric-wide consistency policy affect the local database when the switch is the target of a **distribute** command.

**TABLE 49** Interaction between fabric-wide consistency policy and distribution settings

Distribution setting	Fabric-wide consistency policy		
Absent (default)	Tolerant	Strict	Invalid configuration. <sup>5</sup>
Reject	Database is protected, it cannot be overwritten.  May not match other databases in the fabric.	Invalid configuration. <sup>5</sup>	
Accept (default)	Database is not protected, the database can be overwritten.  If the switch initiating a <b>distribute</b> command has a strict or tolerant fabric-wide consistency policy, the fabric-wide policy is also overwritten.  May not match other databases in the fabric.	Database is not protected.  Automatically distributes activated changes to other v6.2.0 or later switches in the fabric.  If the fabric-wide consistency is set as "strict" for a particular policy, then the manual distribution is blocked.  May not match other databases in the fabric.	Database is not protected.  Automatically distributes activated changes to all switches in the fabric.  Fabric can only contain switches running Fabric OS v6.2.0 or later.  Active database is the same for all switches in the fabric.

<sup>5</sup> An error is returned indicating that the distribution setting must be `Accept` before you can set the fabric-wide consistency policy.

**NOTE**

Starting with Fabric OS 7.3.0, Access Gateways are capable of receiving the password database distributed by native switches and domains. However, the Access Gateways are not capable of distributing the password database to the switches or domains.

## Database distribution settings

The distribution settings control whether a switch accepts or rejects distributions of databases from other switches and whether the switch may initiate a distribution. Configure the distribution setting to reject when maintaining the database on a per-switch basis.

Table 50 lists the databases supported in Fabric OS v6.2.0 and later switches.

**TABLE 50** Supported policy databases

Database type	Database identifier (ID)
Authentication policy database	AUTH
DCC policy database	DCC
FCS policy database	FCS
IP Filter policy database	IPFILTER
Password database	PWD
SCC policy database	SCC

Use the **chassisDistribute** command to distribute IP filter policies. To distribute other security policies, use the **distribute** command. The **distribute** command distributes the database also to Access Gateways in non-VF mode.

## Displaying the database distribution settings

1. Connect to the switch and log in using an account with admin permissions, or an account with OM permissions for the FabricDistribution RBAC class of commands.
2. Enter the **fddCfg --showall** command.

The following sample output shows the database distribution settings.

```
switch:admin> fddcfg --showall
Local Switch Configuration for all Databases:-
  DATABASE - Accept/Reject
-----
      SCC -      accept
      DCC -      accept
      PWD -      accept
      FCS -      accept
      AUTH -     accept
      IPFILTER - accept
Fabric Wide Consistency Policy:- ""
```

## Enabling local switch protection

1. Connect to the switch and log in using an account with admin permissions, or an account with OM permissions for the FabricDistribution RBAC class of commands.
2. Enter the **fddCfg --localreject** command.

## Disabling local switch protection

1. Connect to the switch and log in using an account with admin permissions, or an account with OM permissions for the FabricDistribution RBAC class of commands.
2. Enter the `fddCfg --localaccept` command.

## ACL policy distribution to other switches

This section explains how to manually distribute local ACL policy databases. The `distribute` command has the following dependencies:

- All target switches must be running Fabric OS v6.2.0 or later.
- All target switches must accept the database distribution (refer to [Database distribution settings](#) on page 243).
- The fabric must have a tolerant or no (absent) fabric-wide consistency policy (refer to [Fabric-wide enforcement](#) on page 244).

If the fabric-wide consistency policy for a database is strict, the database cannot be manually distributed. When you set a strict fabric-wide consistency policy for a database, the distribution mechanism is automatically invoked whenever the database changes.

- The local distribution setting must be accepted. To be able to initiate the `distribute` command, set the local distribution to Accept.

## Distributing the local ACL policies

1. Connect to the switch and log in using an account with admin permissions, or an account with OM permissions for the FabricDistribution RBAC class of commands.
2. Enter the `distribute -p` command.

## Fabric-wide enforcement

The fabric-wide consistency policy enforcement setting determines the distribution behavior when changes to a policy are activated. Using the tolerant or strict fabric-wide consistency policy ensures that changes to local ACL policy databases are automatically distributed to other switches in the fabric.

### NOTE

To completely remove all fabric-wide policy enforcement from a fabric, enter the `fddCfg --fabwideset ""` command.

When you set the fabric-wide consistency policy using the `fddCfg` command with the `--fabwideset database_id` option, both the fabric-wide consistency policy and specified database are distributed to the fabric. The active policies of the specified databases overwrite the corresponding active and defined policies on the target switches.

Policy changes that are saved but not activated are stored locally until a policy database change is activated. Activating a policy automatically distributes the Active policy set for that policy type (SCC, DCC, FCS, or any combination of the three) to the other switches in the fabric.

### NOTE

Starting with Fabric OS 7.3.0, FC routers can join a fabric with a strict fabric-wide consistency policy. FC routers do support the fabric-wide consistency policies.

The following table describes the fabric-wide consistency settings.

**TABLE 51** Fabric-wide consistency policy settings

Setting	Value	When a policy is activated
Absent	null	Database is not automatically distributed to other switches in the fabric.



TABLE 51 Fabric-wide consistency policy settings (continued)

Setting	Value	When a policy is activated
Tolerant	<i>database_id</i>	All updated and new policies of the type specified (SCC, DCC, FCS, or any combination) are distributed to all Fabric OS v6.2.0 and later switches in the fabric.
Strict	<i>database_id</i> :S	All updated and new policies of the type specified (SCC, DCC, FCS, or any combination) are distributed to all switches in the fabric.

## Displaying the fabric-wide consistency policy

1. Connect to the switch and log in using an account with admin permissions, or an account with O permission for the FabricDistribution RBAC class of commands.
2. Enter the **fddCfg --showall** command.

The following sample output shows policies for a fabric where no consistency policy is defined.

```
switch:admin> fddcfg --showall
Local Switch Configuration for all Databases:-
  DATABASE - Accept/Reject
-----
      SCC -      accept
      DCC -      accept
      PWD -      accept
      FCS -      accept
      AUTH -     accept
      IPFILTER - accept
Fabric Wide Consistency Policy:- ""
```

## Setting the fabric-wide consistency policy

1. Connect to the switch and log in using an account with admin permissions, or an account with OM permissions for the FabricDistribution RBAC class of commands.
2. Enter the **fddCfg --fabwideset** command.

The following example shows how to set a strict SCC and tolerant DCC fabric-wide consistency policy.

```
switch:admin> fddcfg --fabwideset "SCC:S;DCC"
switch:admin> fddcfg --showall
Local Switch Configuration for all Databases:-
  DATABASE - Accept/Reject
-----
      SCC -      accept
      DCC -      accept
      PWD -      accept
      FCS -      accept
      AUTH -     accept
      IPFILTER - accept
Fabric Wide Consistency Policy:- "SCC:S;DCC"
```

## Notes on joining a switch to the fabric

When a switch is joined to a fabric with a tolerant SCC, DCC, or FCS fabric-wide consistency policy, the joining switch must have a matching tolerant SCC, DCC, or FCS fabric-wide consistency policy. If the tolerant SCC, DCC, or FCS fabric-wide consistency policies do not match, the switch can join the fabric, but an error message flags the mismatch. If the tolerant SCC, DCC, and FCS fabric-wide consistency policies match, the corresponding SCC, DCC, and FCS ACL policies are compared.

The enforcement of fabric-wide consistency policy involves comparison of the Active policy set. If the ACL policies match, the switch joins the fabric successfully. If the ACL policies are absent either on the switch or on the fabric, the switch joins the fabric successfully, and the ACL policies are copied automatically from where they are present to where they are absent. The Active policy set where it is present overwrites the Active and Defined policy set where it is absent. If the ACL policies do not match, the switch cannot join the fabric and the neighboring E\_Ports are disabled.

Use the **fddCfg --fabwideset** command on either this switch or the fabric to set a matching strict SCC, DCC, or FCS fabric-wide consistency policy. Use ACL policy commands to delete the conflicting ACL policy from one side to resolve ACL policy conflict. If neither the fabric nor the joining switch is configured with a fabric-wide consistency policy, there are no ACL merge checks required. Under both conflicting conditions, **secPolicyActivate** is blocked in the merged fabric. Use the **distribute** command to explicitly resolve conflicting ACL policies.

The above descriptions also apply to joining two fabrics. In this context, the joining switch becomes a joining fabric.

### Matching fabric-wide consistency policies

This section describes the interaction between the databases with active SCC and DCC policies and combinations of fabric-wide consistency policy settings when fabrics are merged.

For example: Fabric A with SCC:S;DCC (strict SCC and tolerant DCC) joins Fabric B with SCC:S;DCC (strict SCC and tolerant DCC), the fabrics can merge as long as the SCC policies match, including the order SCC:S;DCC and if both are set to strict.

Table 52 describes the impact of merging fabrics with the same fabric-wide consistency policy that have SCC, DCC, or both policies.

**TABLE 52** Merging fabrics with matching fabric-wide consistency policies

Fabric-wide consistency policy	Fabric A ACL policies	Fabric B ACL policies	Merge results	Database copied
None	None	None	Succeeds	No ACL policies copied.
	None	SCC/DCC	Succeeds	No ACL policies copied.
Tolerant	None	None	Succeeds	No ACL policies copied.
	None	SCC/DCC	Succeeds	ACL policies are copied from B to A.
	SCC/DCC	SCC/DCC	Succeeds	If A and B policies do not match, a warning displays and policy commands are disabled. <sup>6</sup>
Strict	None	None	Succeeds	No ACL policies copied.
	None	SCC/DCC	Succeeds	ACL policies are copied from B to A.
	Matching SCC/DCC	Matching SCC/DCC	Succeeds	No ACL policies copied.
	Different SCC/DCC policies	Different SCC/DCC policies	Fails	Ports are disabled.

### Non-matching fabric-wide consistency policies

You may encounter one of the following two scenarios described in Table 53 and Table 54 where you are merging a fabric with a strict policy to a fabric with an absent, tolerant, or non-matching strict policy and the merge fails and the ports are disabled.

<sup>6</sup> To resolve the policy conflict, manually distribute the database you want to use to the switch with the mismatched database. Until the conflict is resolved, commands such as **fddCfg --fabwideset** and **secPolicyActivate** are blocked.

Table 53 shows merges that are not supported.

**TABLE 53** Examples of strict fabric merges

Fabric-wide consistency policy setting			Expected behavior
	Fabric A	Fabric B	
Strict/Tolerant	SCC:S;DCC:S	SCC;DCC:S	Ports connecting switches are disabled.
	SCC;DCC:S	SCC:S;DCC	
	SCC:S;DCC	SCC:S	
Strict/Absent	SCC:S;DCC:S		
	SCC:S		
	DCC:S		
Strict/Strict	SCC:S	DCC:S	

Table 54 has a matrix of merging fabrics with tolerant and absent policies.

**TABLE 54** Fabric merges with tolerant and absent combinations

Fabric-wide consistency policy setting			Expected behavior
	Fabric A	Fabric B	
Tolerant/Absent	SCC;DCC		Error message logged.
	DCC		Run the <b>fddCfg</b> command with the <b>--fabwideset "policy_ID"</b> from any switch with the desired configuration to fix the conflict. The <b>secPolicyActivate</b> command is blocked until conflict is resolved.
	SCC;DCC	SCC	
	DCC	SCC	

## Management interface security

You can secure an Ethernet management interface between two Brocade switches or Backbones by implementing IPsec and IKE policies to create a tunnel that protects traffic flows. While the tunnel must have a Brocade switch or Backbone at each end, there may be routers, gateways, and firewalls in between the two ends.

### ATTENTION

Enabling secure IPsec tunnels does not provide IPsec protection for traffic flows on the external management interfaces of intelligent blades in a chassis, nor does it support protection of traffic flows on FCIP interfaces.

Internet Protocol security (IPsec) is a framework of open standards that ensures private and secure communications over Internet Protocol (IP) networks through the use of cryptographic security services. The goal of IPsec is to provide the following capabilities:

### NOTE

The **ipSecConfig --enable** command is not supported in Fabric OS 8.0.0.

- **Authentication** -- Ensures that the sending and receiving end-users and devices are known and trusted by one another.
- **Data Integrity** -- Confirms that the data received was in fact the data transmitted.
- **Data Confidentiality** -- Protects the user data being transmitted, such as utilizing encryption to avoid sending data in clear text.
- **Replay Protection** -- Prevents replay attack in which an attacker resends previously-intercepted packets in an effort to fraudulently authenticate or otherwise masquerade as a valid user.
- **Automated Key Management** --Automates the process, as well as manages the periodic exchange and generation of new keys.

Using the **ipSecConfig** command, you must configure multiple security policies for traffic flows on the Ethernet management interfaces based on IPv4 or IPv6 addresses, a range of IPv4 or IPv6 addresses, the type of application, port numbers, and protocols used (UDP/TCP/ICMP). You must specify the transforms and processing choices for the traffic flow (drop, protect or bypass). Also, you must select and configure the key management protocol using an automatic or manual key.

For more information on IPv4 and IPv6 addressing, refer to [Performing Basic Configuration Tasks](#) on page 37.

## Configuration examples

Below are several examples of various configurations you can use to implement an IPsec tunnel between two devices. You can configure other scenarios as nested combinations of these configurations.

### Endpoint-to-endpoint transport or tunnel

In this scenario, both endpoints of the IP connection implement IPsec, as required of hosts in RFC4301. Transport mode encrypts only the payload while tunnel mode encrypts the entire packet. A single pair of addresses will be negotiated for packets protected by this SA.

It is possible in this scenario that one or both of the protected endpoints will be behind a network address translation (NAT) node, in which case tunneled packets will have to be UDP-encapsulated so that port numbers in the UDP headers can be used to identify individual endpoints behind the NAT.

FIGURE 14 Protected endpoints configuration

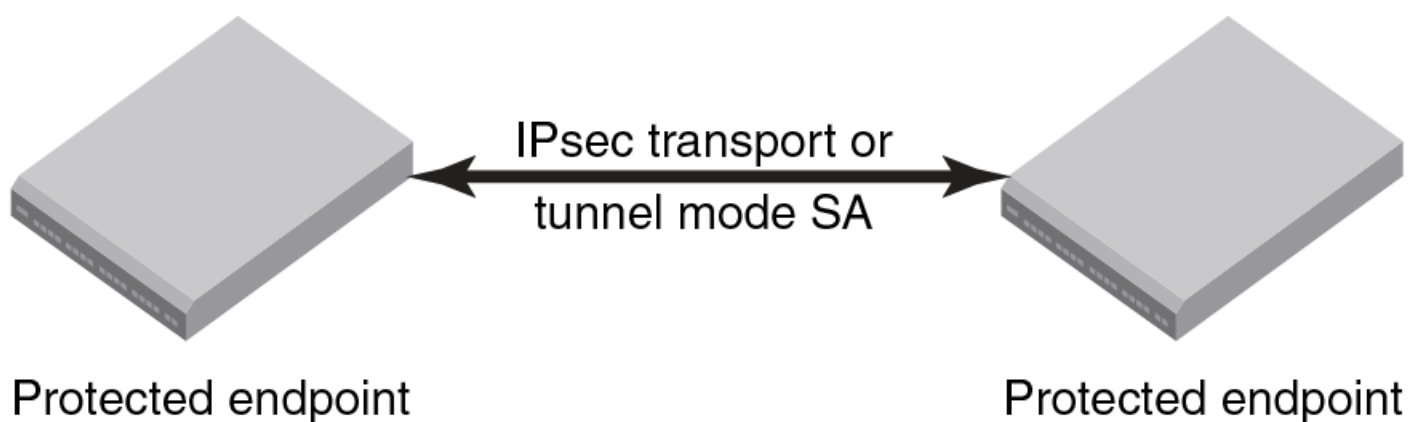

A possible drawback of end-to-end security is that various applications that require the ability to inspect or modify a transient packet will fail when end-to-end confidentiality is employed. Various QoS solutions, traffic shaping, and firewalling applications will be unable to determine what type of packet is being transmitted and will be unable to make the decisions that they are supposed to make.

### Gateway-to-gateway tunnel

In this scenario, neither endpoint of the IP connection implements IPsec, but the network nodes between them protect traffic for part of the way. Protection is transparent to the endpoints, and depends on ordinary routing to send packets through the tunnel endpoints for processing. Each endpoint would announce the set of addresses behind it, and packets would be sent in tunnel mode where the inner IP header would contain the IP addresses of the actual endpoints.

FIGURE 15 Gateway tunnel configuration

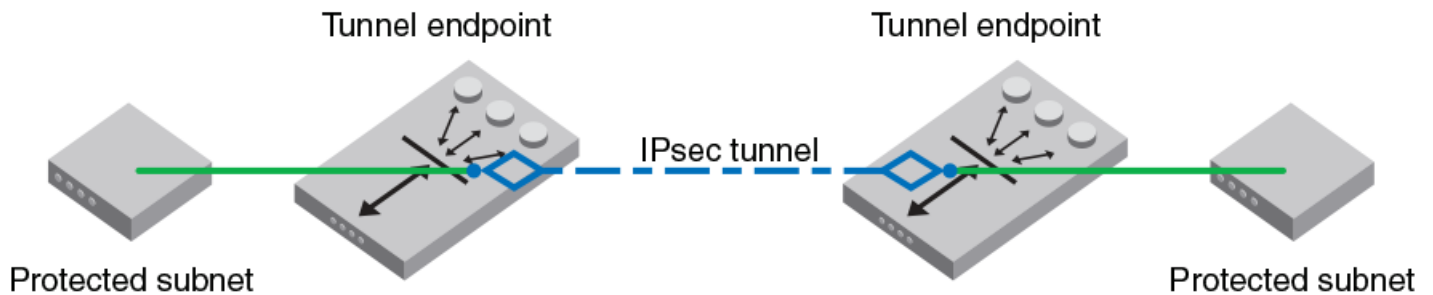

### Endpoint-to-gateway tunnel

In this scenario, a protected endpoint (typically a portable computer) connects back to its corporate network through an IPsec-protected tunnel. It might use this tunnel only to access information on the corporate network, or it might tunnel all of its traffic back through the corporate network in order to take advantage of protection provided by a corporate firewall against Internet-based attacks. In either case, the protected endpoint will want an IP address associated with the security gateway so that packets returned to it will go to the security gateway and be tunneled back.

FIGURE 16 Endpoint-to-gateway tunnel configuration

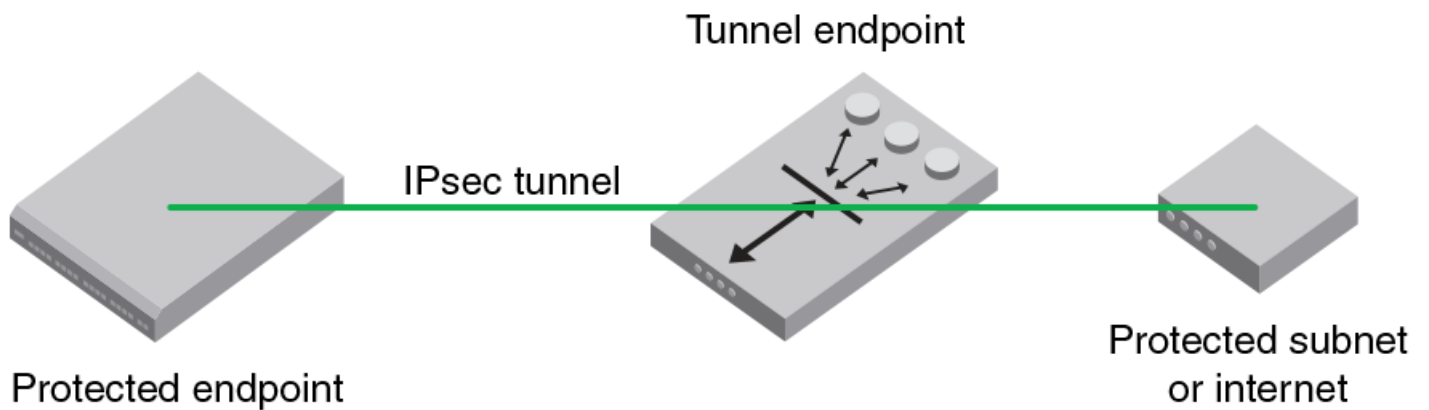

### RoadWarrior configuration

In endpoint-to-endpoint security, packets are encrypted and decrypted by the host which produces or consumes the traffic. In the gateway-to-gateway example, a router on the network encrypts and decrypts the packets on behalf of the hosts on a protected network. A combination of the two is referred to as a RoadWarrior configuration where a host on the Internet requires access to a network through a security gateway that is protecting the network.

### IPsec protocols

IPsec ensures confidentiality, integrity, and authentication using the following protocols:

- Authentication Header (AH)
- Encapsulating Security Payload (ESP)

IPsec protocols protect IP datagram integrity using hash message authentication codes (HMAC). Using hash algorithms with the contents of the IP datagram and a secret key, the IPsec protocols generate this HMAC and add it to the protocol header. The receiver must have access to the secret key in order to decode the hash.

IPsec protocols use a sliding window to assist in flow control. The IPsec protocols also use this sliding window to provide protection against replay attacks in which an attacker attempts a denial of service attack by replaying an old sequence of packets. IPsec protocols assign a sequence number to each packet. The recipient accepts each packet only if its sequence number is within the window. It discards older packets.

## Security associations

A security association (SA) is the collection of security parameters and authenticated keys that are negotiated between IPsec peers to protect the IP datagram. A security association database (SADB) is used to store these SAs. Information in these SAs--IP addresses, secret keys, algorithms, and so on--is used by peers to encapsulate and decapsulate the IPsec packets.

An IPsec security association is a construct that specifies security properties that are recognized by communicating hosts. The properties of the SA are the security protocol (AH or ESP), destination IP address, and Security Parameter Index (SPI) number. SPI is an arbitrary 32-bit value contained in IPsec protocol headers (AH or ESP) and an IPsec SA is unidirectional. Because most communication is peer-to-peer or client-to-server, two SAs must be present to secure traffic in both directions. An SA specifies the IPsec protocol (AH or ESP), the algorithms used for encryption and authentication, and the expiration definitions used in security associations of the traffic. IKE uses these values in negotiations to create IPsec SAs. You must create an SA prior to creating an SA-proposal. You cannot modify an SA once it is created. Use the `ipSecConfig --flush manual-sa` command to remove all SA entries from the kernel SADB and re-create the SA.

## IPsec proposal

The IPsec sa-proposal defines an SA or an SA bundle. An SA is a set of parameters that define how the traffic is protected using IPsec. These are the IPsec protocols to use for an SA, either AH or ESP, and the encryption and authentication algorithms to use to protect the traffic.

For SA bundles, [AH, ESP] is the supported combination.

## Authentication and encryption algorithms

IPsec uses different protocols to ensure the authentication, integrity, and confidentiality of the communication. Encapsulating Security Payload (ESP) provides confidentiality, data integrity and data source authentication of IP packets, and protection against replay attacks. Authentication Header (AH) provides data integrity, data source authentication, and protection against replay attacks, but unlike ESP, AH does not provide confidentiality.

In AH and ESP, `hmac_md5` and `hmac_sha1` are used as authentication algorithms. Only in ESP, `3des_cbc`, `blowfish_cbc`, `aes256_cbc` and `null_enc` are used as encryption algorithms. Use [Table 55](#) when configuring the authentication algorithm.

**TABLE 55** Algorithms and associated authentication policies

Algorithm	Encryption Level	Policy	Description
<code>hmac_md5</code>	128-bit	AH, ESP	A stronger MAC because it is a keyed hash inside a keyed hash. When MD5 or SHA-1 is used in the calculation of an HMAC; the resulting MAC algorithm is termed HMAC-MD5 or HMAC-SHA-1 accordingly.
<code>hmac_sha1</code>	160-bit	AH, ESP	

**TABLE 55** Algorithms and associated authentication policies (continued)

Algorithm	Encryption Level	Policy	Description
			<p><b>NOTE</b> The MD5 hash algorithm is blocked when FIPS mode is enabled</p>
3des_cbc	168-bit	ESP	Triple DES is a more secure variant of DES. It uses three different 56-bit keys to encrypt blocks of 64-bit plain text. The algorithm is FIPS-approved for use by Federal agencies.
blowfish_cbc	64-bit	ESP	Blowfish is a 32-bit to 448-bit keyed, symmetric block cipher.
aes128_cbc	128-bit	ESP	Advanced Encryption Standard is a 128- or 256-bit fixed block size cipher.
aes256_cbc	256-bit	ESP	
null_enc	n/a	ESP	A form of plaintext encryption.

## IPsec policies

An IPsec policy determines the security services afforded to a packet and the treatment of a packet in the network. An IPsec policy allows classifying IP packets into different traffic flows and specifies the actions or transformations performed on IP packets on each of the traffic flows. The main components of an IPsec policy are: IP packet filter and selector (IP address, protocol, and port information) and transform set.

### IPsec traffic selector

The traffic selector is a traffic filter that defines and identifies the traffic flow between two systems that have IPsec protection. IP addresses, the direction of traffic flow (inbound, outbound) and the upper layer protocol are used to define a filter for traffic (IP datagrams) that is protected using IPsec.

### IPsec transform

A *transform set* is a combination of IPsec protocols and cryptographic algorithms that are applied on the packet after it is matched to a selector. The transform set specifies the IPsec protocol, IPsec mode and action to be performed on the IP packet. It specifies the key management policy that is needed for the IPsec connection and the encryption and authentication algorithms to be used in security associations when IKE is used as the key management protocol.

IPsec can protect either the entire IP datagram or only the upper-layer protocols using tunnel mode or transport mode. Tunnel mode uses the IPsec protocol to encapsulate the entire IP datagram. Transport mode handles only the IP datagram payload.

## IKE policies

When IKE is used as the key management protocol, IKE policy defines the parameters used in IKE negotiations needed to establish IKE SA and parameters used in negotiations to establish IPsec SAs. These include the authentication and encryption algorithms, and the primary authentication method, such as preshared keys, or a certificate-based method, such as RSA signatures.

## Key management

The IPsec key management supports Internet Key Exchange or Manual key/SA entry. The Internet Key Exchange (IKE) protocol handles key management automatically. SAs require keying material for authentication and encryption. The managing of keying material that SAs require is called *key management*.

The IKE protocol secures communication by authenticating peers and exchanging keys. It also creates the SAs and stores them in the SADB.

The manual key/SA entry requires the keys to be generated and managed manually. For the selected authentication or encryption algorithms, the correct keys must be generated using a third party utility on your LINUX system. The key length is determined by the algorithm selected.

Linux IPsec-tools 0.7 provides tools for manual key entry (MKE) and automatic keyed connections. The LINUX **setKey** command can be used for manually keyed connections, which means that all parameters needed for the setup of the connection are provided by you. Based on which protocol, algorithm, and key used for the creation of the security associations, the switch populates the security association database (SAD) accordingly.

## Pre-shared keys

A pre-shared key has the .psk extension and is one of the available methods IKE can be configured to use for primary authentication. You can specify the pre-shared keys used in IKE policies; add and delete pre-shared keys (in local database) corresponding to the identity of the IKE peer or group of peers.

The **ipSecConfig** command does not support manipulating pre-shared keys corresponding to the identity of the IKE peer or group of peers. Use the **secCertUtil** command to import, delete, or display the pre-shared keys in the local switch database. For more information on this procedure, refer to [Configuring Protocols](#) on page 185.

## Security certificates

A certificate is one of the available methods IKE can be configured to use for primary authentication. You can specify the local public key and private key (in X.509 PEM format) and peer public key (in X.509 format) to be used in a particular IKE policy.

Use the **secCertUtil import** command to import public key, private key and peer-public key (in X.509 PEM format) into the switch database. For more information on this procedure, refer to [Configuring Protocols](#) on page 185.

### ATTENTION

The CA certificate name must have the `IPSECCA.pem` name.

## Static Security Associations

Manual Key Entry (MKE) provides the ability to manually add, delete and flush SA entries in the SADB. Manual SA entries may not have an associated IPsec policy in the local policy database. Manual SA entries are persistent across system reboots.

## Creating the tunnel

Each side of the tunnel must be configured in order for the tunnel to come up. Once you are logged into the switch, do not log off as each step requires that you be logged in to the switch. IPsec configuration changes take effect upon execution and are persistent across reboots. Configure the following on each side of the tunnel:

1. Determine the authentication protocol and algorithm to be used on the tunnel.  
Refer to [Table 55](#) on page 250 to determine which algorithm to use in conjunction with a specific authentication protocol.
2. Determine the type of keys to be used on the tunnel.



If you are using CA signed keys, you must generate them prior to setting up your tunnels.

3. Enable IPsec.
  - a) Connect to the switch and log in using an account with admin permissions, or an account associated with the chassis role and having OM permissions for the IPsec RBAC class of commands.
  - b) Enter the `ipSecConfig --enable` command to enable IPsec on the switch.
4. Create an IPsec SA policy on each side of the tunnel using the `ipSecConfig --add` command.

Example of creating an IPsec SA policy

This example creates an IPsec SA policy named "AH01", which uses AH protection with MD5. You would run this command on each switch; on each side of the tunnel so that both sides have the same IPsec SA policy.

```
switch:admin> ipsecconfig --add policy ips sa -t AH01 -p ah -auth hmac_md5
```

5. Create an IPsec proposal on each side of the tunnel using the `ipSecConfig --add` command.

Example of creating an IPsec proposal

This example creates an IPsec proposal "IPSEC-AH" to use "AH01" as SA.

```
switch:admin> ipsecconfig --add policy ips sa-proposal -t IPSEC-AH -sa AH01
```

6. Import the pre-shared key file.  
Refer to [Configuring Protocols](#) on page 185 for information on how to set up pre-shared keys and certificates.
7. Configure the IKE policy using the `ipSecConfig --add` command.

Example of creating an IKE policy

This example creates an IKE policy for the remote peer.

```
switch:admin> ipsecconfig --add policy ike -t IKE01 -remote 10.33.74.13
-id 10.33.69.132 -remoteid 10.33.74.13 -enc 3des_cbc -hash hmac_md5
-prf hmac_md5 -auth psk -dh modp1024 -psk ipseckey.psk
```

8. Create an IPsec transform on each switch using the `ipSecConfig --add` command.

Example of creating an IPsec transform

This example creates an IPsec transform TRANSFORM01 to use the transport mode to protect traffic identified for IPsec protection and use IKE01 as key management policy.

```
switch:admin> ipsecconfig --add policy ips transform -t TRANSFORM01
-mode transport -sa-proposal IPSEC-AH -action protect -ike IKE01
```

9. Create a traffic selector on each switch using the `ipSecConfig --add` command.

Example of creating a traffic selector

This example creates a traffic selector to select outbound and inbound traffic that needs to be protected.

```
switch:admin> ipsecconfig --add policy ips selector -t SELECTOR-OUT -d out
-l 10.33.69.132 -r 10.33.74.13 -transform TRANSFORM01
switch:admin> ipsecconfig --add policy ips selector -t SELECTOR-IN -d in
-l 10.33.74.13 -r 10.33.69.132 -t transform TRANSFORM01
```

Inbound and outbound selectors use opposite values for local and remote IP addresses. In this example, notice that the local ("-l") address of SELECTOR-OUT is the same as the remote ("-r") address of SELECTOR-IN. Similarly, the local ("-l") address of SELECTOR-IN is the same as the remote ("-r") address of SELECTOR-OUT. That is, "local" refers to the source IP address of

the packet, and "remote" is the destination IP address. Hence inbound packets have opposite source and destination addresses than outbound packets.

10. Verify traffic is protected.
  - a) Initiate a telnet, SSH, or ping session from the two switches.
  - b) Verify that IP traffic is encapsulated.
  - c) Monitor IPsec SAs created using IKE for above traffic flow
    - Use the `ipSecConfig --show manual-sa -a` command with the operands specified to display the outbound and inbound SAs in kernel SADB.
    - Use the `ipSecConfig --show policy ips sa -a` command with the specified operands to display all IPsec SA policies.
    - Use the `ipSecConfig --show policy ips sa-proposal -a` command with the specified operands to display IPsec proposals.
    - Use the `ipSecConfig --show policy ips transform -a` command with the specified operands to display IPsec transforms.
    - Use the `ipSecConfig --show policy ips selector -a` command with the specified operands to display IPsec traffic selectors.
    - Use the `ipSecConfig --show policy ike -a` command with the specified operands to display IKE policies.
    - Use the `ipSecConfig --flush manual-sa` command with the specified operands to flush the created SAs in the kernel SADB.

## Example of an end-to-end transport tunnel mode

This example illustrates securing traffic between two systems using AH protection with MD5 and configure IKE with pre-shared keys. The two systems are a switch, BROCADE300 (IPv4 address 10.33.74.13), and an external host (10.33.69.132).

1. On the system console, log in to the switch as Admin.
2. Enable IPsec.
  - a) Connect to the switch and log in using an account with admin permissions, or an account with OM permissions for the IPsec RBAC class of commands.
  - b) Enter the `ipSecConfig --enable` command to enable IPsec on the switch.
3. Create an IPsec SA policy named AH01, which uses AH protection with MD5.

```
switch:admin> ipsecconfig --add policy ips sa -t AH01 -p ah -auth hmac_md5
```

4. Create an IPsec proposal IPSEC-AH to use AH01 as SA.

```
switch:admin> ipsecconfig --add policy ips sa-proposal -t IPSEC-AH -sa AH01
```

5. Configure the SA proposal's lifetime in time units. The maximum lifetime is 86400, or one day.

```
switch:admin> ipsecconfig --add policy ips sa-proposal -t IPSEC-AH
-lifetime 86400 -sa AH01
```

6. Import the pre-shared key file using the `secCertUtil` command. The file name should have a .psk extension. For more information on importing the pre-shared key file, refer to [Installing a switch certificate](#) on page 198.
7. Configure an IKE policy for the remote peer.

```
switch:admin> ipsecconfig --add policy ike -t IKE01 -remote 10.33.69.132
-id 10.33.74.13 -remoteid 10.33.69.132 -enc 3des_cbc -hash hmac_md5
```

```
-prf hmac_md5 -auth psk -dh modp1024 -psk ipseckey.psk
```

#### NOTE

IKE version ('-v' option) needs to be set to 1 (IKEv1) if remote peer is a Windows XP or 2000 Host as Windows XP and 2000 do not support IKEv2.

8. Create an IPsec transform named TRANSFORM01 to use transport mode to protect traffic identified for IPsec protection and use IKE01 as key management policy.

```
switch:admin> ipsecconfig --add policy ips transform -t TRANSFORM01
-mode transport -sa-proposal IPSEC-AH -action protect -ike IKE01
```

9. Create traffic selectors to select the outbound and inbound traffic that needs to be protected.

```
switch:admin> ipsecconfig --add policy ips selector -t SELECTOR-OUT -d out
-l 10.33.74.13 -r 10.33.69.132 -transform TRANSFORM01
```

```
switch:admin> ipsecconfig --add policy ips selector -t SELECTOR-IN -d in
-l 10.33.69.132 -r 10.33.74.13 -transform TRANSFORM01
```

10. Verify the IPsec SAs created with IKE using the **ipSecConfig --show manual-sa -a** command.
11. Perform the equivalent steps on the remote peer to complete the IPsec configuration. Refer to your server administration guide for instructions.
12. Generate IP traffic and verify that it is protected using defined policies.
  - a) Initiate Telnet or SSH or ping session from BRCD300 to Remote Host.
  - b) Verify that the IP traffic is encapsulated.
  - c) Monitor IPsec SAs created using IKE for the above traffic flow.
    - Use the **ipSecConfig --show manual-sa -a** command with the operands specified to display the outbound and inbound SAs in the kernel SADB.
    - Use the **ipSecConfig --show policy ips sa -a** command with the specified operands to display all IPsec SA policies.
    - Use the **ipSecConfig --show policy ips sa-proposal -a** command with the specified operands to display IPsec proposals.
    - Use the **ipSecConfig --show policy ips transform -a** command with the specified operands to display IPsec transforms.
    - Use the **ipSecConfig --show policy ips selector -a** command with the specified operands to display IPsec traffic selectors.
    - Use the **ipSecConfig --show policy ike -a** command with the specified operands to display IKE policies.
    - Use the **ipSecConfig --flush manual-sa** command with the specified operands to flush the created SAs in the kernel SADB.

#### ATTENTION

Flushing SAs requires IPsec to be disabled and re-enabled. This operation is disruptive to traffic using the tunnel.

## Notes

- As of Fabric OS 7.0.0, IPsec no longer supports null encryption (null\_enc) for IKE policies.
- IPv6 policies cannot tunnel ICMP traffic.



# Maintaining the Switch Configuration File

- Configuration settings..... 257
- Configuration file backup..... 259
- Configuration file restoration..... 261
- Configurations across a fabric..... 264
- Configuration management for Virtual Fabrics..... 264
- Brocade configuration form..... 266

## Configuration settings

It is important to maintain consistent configuration settings on all switches in the same fabric because inconsistent parameters, such as inconsistent PID formats, can cause fabric segmentation. As part of standard configuration maintenance procedures, Brocade recommends that you back up all important configuration data for every switch on a host computer server as a safety measure.

### NOTE

For more information about troubleshooting configuration file uploads and downloads, refer to the *Fabric OS Troubleshooting and Diagnostics Guide*.

There are two ways to view configuration settings for a switch in a Brocade fabric:

- Issue the **configShow -all** command.

To display configuration settings, connect to the switch, log in as admin, and enter the **configShow -all** command. The configuration settings vary depending on switch model and configuration. This command does not show as much configuration information as the text file created from the **configUpload** command.

- Issue the **configUpload -all** command to upload an ASCII text file from the switch or switch module.

You can open the text file with any text editor to view the configuration information of the switch.



### CAUTION

Editing of the uploaded file is unsupported and can result in system errors if an edited file is subsequently downloaded.

If your user account has chassis account permissions, you can use any of the following options when uploading or downloading a configuration file:

<b>-fid</b>	To upload the specified FID configuration.
<b>-all</b>	To upload all of the system configuration, including the chassis section and all switch sections for all logical switches.  <b>NOTE</b> Use this parameter when obtaining a complete capture of the switch configuration in a switch that has Virtual Fabrics mode disabled.
<b>-chassis</b>	To upload only the chassis section of the system configuration file.
<b>-switch</b>	To upload the switch configuration only, if Virtual Fabrics mode is disabled.
<b>-cra</b>	Challenge Response Authentication (CRA) is to be used with SCP. You can run this command without arguments for interactive mode. Only a password is supported as a challenge.

<b>-map</b>	Uploads the port-to-area addressing mode configuration files. This command should be used in FICON environment before replacing both the CP blades.
<b>-vf</b>	Upload the virtual fabric data.

## Configuration file format

The configuration file is divided into three areas: the header, the chassis section, and one or more logical-switch sections.

### Chassis section

There is only one chassis section within a configuration. It defines configuration data for chassis components that affect the entire system, not just one individual logical switch. The chassis section is included in non-Virtual Fabric modes only if you use the **configUpload -all** command.

The chassis section specifies characteristics for the following software components:

- FC Routing - Fibre Channel Routing
- Chassis configuration - Chassis configuration
- FCOE\_CH\_CONF - FCoE chassis configuration
- UDROLE\_CONF - User-defined role configuration
- LicensesDB - License Database (newer-format license storage)
- DMM\_WWN - Data migration manager World Wide Name configuration
- License Database - (older-format license storage)
- AGWWN\_MAPPING\_CONF - Access Gateway WWN mapping configuration
- LicensesLservc - Sentinel License configuration
- GE blade mode - GigE Mode configuration
- FRAME LOG - Frame log configuration (enable/disable)
- DMM\_TB - Data migration manager configuration
- MOTD - Message of the day

### Switch section

There is always at least one switch section for the default switch or a switch that has Virtual Fabrics mode disabled, and there are additional sections corresponding to each additionally defined logical switch instance on a switch with Virtual Fabrics mode enabled. This data is switch-specific and affects only that logical switch behavior.

The switch section of the configuration file contains information for all of the following:

- Boot parameters
- Configuration
- Bottleneck configuration
- Flow Vision configuration
- FCoE software configuration
- Zoning
- Defined security policies
- Active security policies

- iSCSI
- CryptoDev
- FICU saved files
- VS\_SW\_CONF
- MAPS configuration
- Banner

## Configuration file backup

Brocade recommends keeping a backup configuration file. You should keep individual backup files for all switches in the fabric and avoid copying configurations from one switch to another. The **configUpload** command, by default, only uploads the switch context configuration for the logical switch context in which the command is executed.

In non-Virtual Fabric mode, you must use the **configUpload -all** command to include both the switch and the chassis information. In Virtual Fabric mode, the **configUpload -all** command can be selected to upload all logical switches and the chassis configuration. Only administrators with chassis permissions are allowed to upload other FIDs or the chassis configuration.

The following information is *not saved* in a backup:

- **dnsConfig** command information
- Passwords

Before you upload a configuration file, verify that you can reach the FTP server from the switch. Using a Telnet connection, save a backup copy of the configuration file from a logical switch to a host computer.

Secure File Transfer Protocol (SFTP) is now an option when uploading a configuration file. SFTP is analogous to Secure Copy Protocol (SCP). SFTP can be used for the **configupload**, **configdownload**, **supportsave**, and auto FFDC/trace upload (**supportftp**) commands.

### NOTE

If you download a configuration file which was uploaded from a switch whose default FID (128) was changed, then you should download the VF configuration file first before you download the normal configuration file to ensure that all the logical switches are same in both switches. Hence, follow these steps:

1. Run the **configUpload -vf** command from the old setup.
2. Run the **configUpload -all** command from the old setup.
3. Run the **configDownload -vf** command in the new setup.
4. Run the **configDownload -all** command in the new setup.

## Considerations for FTP server credentials with special characters

FTP server credentials may include special characters that need to be handled in specified manner on the Command Line Interface (CLI).

Special characters also referred to as meta-characters, are members of an exempt set of characters, which when used in command line mode are evaluated as characters with non-literal meaning. These characters are designated to carry out a special instruction, or have an alternate meaning.

### NOTE

This list is not exhaustive and alternate meaning for some characters is contextual. For more information, refer to any Linux scripting information available for general use on the internet.

A list of some of the more commonly used special characters and their alternate meaning is as follows:

- `&` is used to put a command in background/batch mode.
- `!` is used to recall the last invocation of the command matching the pattern that follows the character.
- `|` is used to pipe output to the command that follows the character.
- `;` is used to concatenate multiple bash commands.
- `*` is used to represent a wildcard character.
- `?` is used as a match for any single character in the specified position.
- `()` is used for integer expansion.
- `<>` is used for redirection. `<` represents input and `>` represents output.
- `$` is used to represent shell variable.
- ``` is used for command substitution or assign output of a command to a variable.
- `"` is used for partial quoting.
- `'` is used for full quoting.
- Space is used as a separation character.
- `#` when preceded by a space, treats all characters till the end of the corresponding line as a comment.

These special characters may be used to enhance the security of the user credentials. However, to interpret these characters properly in the CLI mode, you must follow one of the following methods:

- Escape each instance of the special character by preceding it with the escape character (`\`).
- Enclose the credentials containing special characters, with single quotes.

If single quotes are themselves part of the credential, precede each instance of the single quote with the escape character (`\`). Alternately, the string may be enclosed in double quotes if more intricate bash substitution is desired to further strengthen the security measure of the credentials.

For detailed information on using the special characters in the credentials, refer to any Linux scripting information available for general use on the internet.

You can test the representation of the credentials using the echo tests.

## Examples to verify the use of special characters

To verify the use of single quote for the password `aaa!01`:

```
switch:admin> echo `aaa!01`
aaa!01
```

To verify escaping `!` without quotes for the password `aaa!01`:

```
switch:admin> echo aaa\!01
aaa!01
```

To verify using the quotes, excluding the `\!` for password `aaa!01`:

```
switch:admin> echo "aaa"\!"01"
aaa!01
```

To verify using the quotes without excluding the `\!` for password `aaa!01`, resulting in different password pattern:

```
switch:admin> "aaa\!01"
aaa\!01
```



To verify using the quotes around the \! for password aaa!01, resulting in different password pattern:

```
switch:admin> echo `aaa!01`
aaa!01
```

## Uploading a configuration file in interactive mode

1. Verify that the FTP, SFTP, or SCP service is running on the host computer.
2. Connect to the switch and log in using an account with admin permissions.
3. Enter the **configUpload** command. The command becomes interactive and you are prompted for the required information.
4. Store a soft copy of the switch configuration information in a safe place for future reference.

```
switch:admin> configupload
Protocol (scp, ftp, sftp, local) [ftp]: sftp
Server Name or IP Address [host]: 10.1.2.3
User Name [user]: UserFoo
Path/Filename [<home dir>/config.txt]: switchConfig.txt
Section (all|chassis|FID# [all]): chassis
username@10.1.2.3
's password:
Password: <hidden>
configUpload complete
```

## Configuration file restoration

When you restore a configuration file, you overwrite the existing configuration with a previously saved backup configuration file.



### CAUTION

Make sure that the configuration file you are downloading is compatible with your switch model. Downloading a configuration file from a different switch model or from a different firmware could cause your switch to fail.



### CAUTION

If you have Virtual Fabrics enabled, you must follow the procedure in [Configuration management for Virtual Fabrics](#) on page 264 to restore the logical switches.

If a **configDownload** command is issued on a non-FC router, any FC router parameters may be viewed in the downloaded data. This is harmless to the switch and can be ignored.

MAPS configuration is downloaded onto the switch only if MAPS is enabled on the local switch.

You can download the configuration file from a device with Fabric OS 7.2.0 or Fabric OS 7.3.0 to Fabric OS 7.4.0.

You can use the **configDownload** command to restore the switch configuration.

```
configdownload -vf config_VF file
configdownload -all config_All file
```

## Restrictions

This section lists restrictions for some of the options of the **configDownload** command.

Option	Restrictions
<b>-chassis</b>	The number of switches defined in the downloaded configuration file must match the number of switches currently defined on the switch.
<b>-fid</b> <i>FID</i>	The FID must be defined in both the downloaded configuration file and the current system.

Option	Restrictions
	<p><b>NOTE</b>                      Brocade recommends you disable a switch before downloading a configuration file. If you plan to download a configuration file while the switch is enabled, refer to <a href="#">Configuration download without disabling a switch</a> on page 263.</p>
<b>-fid</b> <i>FID</i> <b>-sfid</b> <i>FID</i>	The FID must be defined on the switch and the source FID must be defined in the downloaded configuration file.
<b>-all</b>	<p>The number of switches or FIDs defined in the downloaded configuration file must match the number of switches or FIDs currently defined on the switch.</p> <p>The switches must be disabled first. If they are not, the <b>configDownload</b> command will download the configuration for as many switches as possible until a non-disabled switch is found. If a non-disabled switch is found, the downloading process stops. Before running the <b>configDownload</b> command, verify if any switches must be disabled.</p> <p>If you are performing a configuration download due to a configuration error, it is highly recommended to run the <b>configDefault</b> command before running the <b>configDownload</b> command. Refer to <a href="#">Configuration download without disabling a switch</a> on page 263 for more information on non-disruptive configuration downloads.</p> <p>If Virtual Fabrics mode is enabled, the <b>chassisDisable</b> and <b>chassisEnable</b> commands are used to disable all logical switches on the affected switch. This process bypasses the need to disable and enable each switch individually once the configuration download has completed.</p> <p>Non-Virtual Fabric configuration files downloaded to a Virtual Fabric system have a configuration applied only to the default switch. If there are multiple logical switches created in a Virtual Fabric-enabled system, there may be problems if there are ports that belong to the default switch in a Virtual Fabric-disabled system, but are now assigned to logical switches in a Virtual Fabric-enabled system. Only configurations related to ports within the default switch are applied.</p>

If you must set up your switch again, run the commands listed in [Table 57](#) and save the output in a file format. Store the files in a safe place for emergency reference.

**TABLE 57** CLI commands to display or modify switch configuration information

Command	Displays
<b>configShow</b>	System configuration parameters, settings, and license information.
<b>fcLunQuery</b>	LUN IDs and LUNs for all accessible targets.
<b>fcRouterPortCost</b>	FC Router route information.
<b>fcxlateConfig</b>	Translate (xlate) domain's domain ID for both EX_Port-attached fabric and backbone fabric.
<b>fosConfig</b>	Fabric OS features.
<b>ipAddrShow</b>	IP address.
<b>isnscCfg</b>	Configuration state of the iSNS client operation.
<b>licenseShow</b>	License keys installed with more detail than the license information from the <b>configShow</b> command.
<b>portCfgEXPort</b>	EX_Port configuration parameters.
<b>portCfgVEXPort</b>	VEX_Port configuration parameters.



**CAUTION**

Though the switch itself has advanced error checking, the configdownload feature within Fabric OS was not designed for users to edit, and is limited in its ability. Edited files can become corrupted and this corruption can lead to switch failures.

**NOTE**

If you download a configuration file with either the **portCfgEportCredits** or **portCfgFportBuffers** entries manually removed, the switch will retain the existing configuration even after configuration download.

## Configuration download without disabling a switch

You can download configuration files to a switch while the switch is enabled; that is, you do not need to disable the switch for changes in SNMP, MAPS, Fabric Watch, or ACL parameters. However, if there is any changed parameter that does not belong to SNMP, MAPS, or ACL, then you must disable the switch. When you use the **configDownload** command, you are prompted to disable the switch *only when necessary*.

### ATTENTION

The configuration download process can restore only logical switches that already exist and that use the same FIDs. It cannot be used to clone or repair the current switch because the **configDownload** command cannot create logical switches if they do not exist.

## Restoring a configuration



### CAUTION

Using the SFID parameter erases all configuration information on the logical switch. Use the SFID parameter only when the logical switch has no configuration information you want to save.

1. Verify that the FTP service is running on the server where the backup configuration file is located.
2. Connect to the switch and log in using an account with admin permissions, and if necessary, with chassis permissions.
3. If there are any changed parameters in the configuration file that do not belong to SNMP, Fabric Watch, or ACL, disable the switch by entering the **switchDisable** command.
4. Enter the **configDownload** command.

The command becomes interactive and you are prompted for the required information.

5. At the "Do you want to continue [y/n]" prompt, enter **y**.

Wait for the configuration to be restored.

6. If you disabled the switch, enter the **switchEnable** command when the process is finished.

### NOTE

Always perform a reboot after you download a configuration file. On dual-CP platforms, you must reboot both CPs simultaneously.

```
switch:admin> configdownload
Protocol (scp, ftp, local) [ftp]:
Server Name or IP Address [host]: 10.1.2.3
User Name [user]: UserFoo
Path/Filename [<home dir>/config.txt]:
Section (all|chassis|FID# [all]): all
*** CAUTION ***
```

This command is used to download a backed-up configuration for a specific switch. If using a file from a different switch, this file's configuration settings will override any current switch settings. Downloading a configuration file, which was uploaded from a different type of switch, may cause this switch to fail. A switch reboot is required for the changes to take effect. Please make sure all the switches are disabled by using "chassisdisable" command. Downloading configuration to an online switch may result in some configuration not being downloaded to that switch. configDownload operation may take several minutes to complete for large files. Do you want to continue [y/n]:y  
Password: <hidden>  
configDownload complete.

### Example of a non-interactive download of all configurations (chassis and switches)

```
configdownload -a -ftp 10.1.2.3,UserFoo,/pub/configurations/config.txt,password
```

## Configurations across a fabric

To save time when configuring fabric parameters and software features, you can save a configuration file from one switch and download it to other switches of the same model type.

Do not download a configuration file from one switch to another switch that is a different model or runs a different firmware version, because it can cause the switch to fail. If you need to reset affected switches, issue the **configDefault** command after download is completed but before the switch is enabled. If a switch is enabled with a duplicate domain ID, the switch becomes segmented.

## Downloading a configuration file from one switch to another switch of the same model

1. Configure one switch.
2. Use the **configUpload** command to save the configuration information. Refer to [Configuration file backup](#) on page 259 for more information.
3. Run **configDefault** on each of the target switches, and then use the **configDownload** command to download the configuration file to each of the target switches. Refer to [Configuration file restoration](#) on page 261 for more information.

## Security considerations

Security parameters and the switch identity cannot be changed by the **configDownload** command. Parameters such as the switch name and IP address (lines in the configuration file that begin with "boot") are ignored. Security parameters (lines in the configuration file that begin with "sec"), such as secure mode setting and version stamp, are ignored. For more detailed information on security, refer to [Configuring Protocols](#) on page 185.

## Configuration management for Virtual Fabrics

You can use the **configUpload -vf** or **configDownload -vf** command to restore configurations to a logical switch. The **-vf** option only restores the Virtual Fabrics configuration information on to a switch of the same model and same release. For example, a Virtual Fabrics configuration file for Fabric OS 7.4.x cannot be used on a Fabric OS 7.2.x switch and vice versa.

The Virtual Fabrics configuration on the switch defines all of the logical switches allowed and configured for a particular platform.

## Uploading a configuration file from a switch with Virtual Fabrics enabled

The **configUpload** command with the **-vf** option specifies that configuration upload will upload the Virtual Fabrics configuration instead of the non-Virtual Fabrics configuration information.

You must specify a file name with the **configUpload -vf** command. It is recommended not to use config.txt for a file name as this name can be confused with a normal uploaded configuration file.

### Example of configUpload on a switch with Virtual Fabrics

```
DCX_80:FID128:admin> configupload -vf
Protocol (scp, ftp, sftp, local) [ftp]:
Server Name or IP Address [host]: 10.1.2.3
User Name [user]: anonymous
Path/File name [<home dir>/config.txt]: 5100_vf.txt
configUpload complete: VF config parameters are uploaded
2014/07/20-09:13:40, [LOG-1000], 225, SLOT 7 | CHASSIS, INFO, BrocadeDCX, Previous message repeated 7
time(s)
```

```
2014/07/20-10:27:14, [CONF-1001], 226, SLOT 7 | FID 128, INFO, DCX_80, configUpload completed successfully
for VF config parameters.
```

### Example of configUpload on a logical switch configuration

```
Sprint5100:FID128:admin> configupload
Protocol (scp, ftp, sftp, local) [ftp]:
Server Name or IP Address [host]: 10.1.2.3
User Name [user]: UserFoo
Path/Filename [<home dir>/config.txt]: 5100.txt
Potentially remote file may get overwritten
Section (all|chassis|FID# [all]):
Password: <hidden>
configUpload complete: All selected config parameters are uploaded
```

## Restoring a logical switch configuration using configDownload

The **configDownload -vf** command specifies that the Virtual Fabrics configuration download file is downloaded instead of the regular configuration. After the Virtual Fabrics configuration file is downloaded, the switch is automatically rebooted.

On dual-CP platforms, if CPs are incompatible (HA not in sync), the Virtual Fabrics configuration file is not propagated to the standby CP. If CPs are compatible, the active CP attempts to remain active after the reboot, and the new Virtual Fabrics configuration file is then propagated to the standby CP.



### CAUTION

You must issue the **configDownload** command on the switch after restoring the Virtual Fabrics configuration to fully restore your switch or chassis configuration.

1. Connect to the switch and log in using an account with admin permissions.
2. Enter the **configDownload -vf** command.
3. Respond to the prompts.  
Wait for the configuration file to download on to the switch. You may need to reconnect to the switch.
4. Enter the **configDownload -all** command.
5. Respond to the prompts.  
Wait for the configuration file to download to the switch.
6. Verify the LISL ports are set up correctly.

### Example of a non-interactive download from a switch with FID = 8 and SFID = 10

```
configdownload -fid 8 -sfid 10 -ftp 10.1.2.3
,UserFoo
,config.txt,password
```

### Example of configDownload on a switch

```
5100:FID128:admin> configdownload -vf
Protocol (scp, ftp, sftp, local) [ftp]:
Server Name or IP Address [host]: 10.1.2.3
User Name [user]: UserFoo
Path/Filename [<home dir>/config.txt]: 5100_FID89.txt
*** CAUTION ***
This command is used to download the VF configuration to the
switch. Afterwards, the switch will be automatically rebooted
and the new VF settings will be used. You will then need to
run configdownload again to install the configuration(s) for
any logical switch(s) that are setup in the new VF configuration.
Do you want to continue [y/n]: y
(output truncated)
```

## Restrictions

The following restrictions apply when using the **configUpload** or **configDownload** commands when Virtual Fabrics mode is enabled:

- The **-vf** option is incompatible with the **-fid**, **-sfid**, or **-all** options. Any attempt to combine it with any of the other three will cause the configuration upload or download operation to fail.
- You are not allowed to modify the Virtual Fabrics configuration file after it has been uploaded. Only minimal verification is done by the **configDownload** command to ensure it is compatible, much like the normal downloaded configuration file.
- After the **configDownload -vf** command completes and reboots your switch, you must then download the matching regular configuration using the **configDownload -all** command. This ensures proper behavior of the system and logical switches.

All of the attributes of the Virtual Fabrics configuration file will be downloaded to the system and take effect. This includes, but is not limited to, logical switch definitions, whether Virtual Fabrics is enabled or disabled, and the F\_Port trunking ports, except the LISL ports. The LISL ports on the system are not affected by the Virtual Fabrics configuration file download.

You can restore Virtual Fabrics configurations only to a switch of the same model and same release. For example, a Virtual Fabrics configuration file for Fabric OS 7.2.x cannot be used on a Fabric OS 7.1.x switch and vice versa.

## Brocade configuration form

Use the form in [Table 58](#) as a hard copy reference for your configuration information.

**TABLE 58** Brocade configuration and connection form

Brocade configuration settings	
IP address	
Gateway address	
Chassis configuration option	
Management connections	
Serial cable tag	
Ethernet cable tag	
Configuration information	
Domain ID	
Switch name	
Ethernet IP address	
Ethernet subnet mask	
Total number of local devices ( <b>nsShow</b> )	
Total number of devices in fabric ( <b>nsAllShow</b> )	
Total number of switches in the fabric ( <b>fabricShow</b> )	

# Managing Virtual Fabrics

---

• Virtual Fabrics overview.....	267
• Logical switch overview.....	268
• Management model for logical switches.....	273
• Logical fabric overview.....	274
• Account management and Virtual Fabrics.....	279
• Setting up IP addresses for a logical switch.....	279
• Supported platforms for Virtual Fabrics.....	281
• Virtual Fabrics interaction with other Fabric OS features.....	282
• Limitations and restrictions of Virtual Fabrics.....	283
• Enabling Virtual Fabrics mode.....	284
• Disabling Virtual Fabrics mode.....	285
• Configuring logical switches to use basic configuration values.....	286
• Creating a logical switch or base switch.....	286
• Executing a command in a different logical switch context.....	288
• Deleting a logical switch.....	288
• Adding and moving ports on a logical switch.....	289
• Displaying logical switch configuration.....	290
• Changing the fabric ID of a logical switch.....	290
• Changing a logical switch to a base switch.....	291
• Configuring a logical switch for XISL use .....	292
• Changing the context to a different logical fabric.....	293
• Creating a logical fabric using XISLs.....	293

## Virtual Fabrics overview

Virtual Fabrics is an architecture to virtualize hardware boundaries. Traditionally, SAN design and management is done at the granularity of a physical switch. Virtual Fabrics allows SAN design and management to be done at the granularity of a port.

Virtual Fabrics is a suite of related features that can be customized based on your needs. The Virtual Fabrics suite consists of the following specific features:

- Logical switch
- Logical fabric
- Device sharing

This chapter describes the logical switch and logical fabric features. For information about device sharing with Virtual Fabrics, refer to [FC-FC routing and Virtual Fabrics](#) on page 539.

### NOTE

A note on terminology: *Virtual Fabrics* is the name of the suite of features. A *logical fabric* is a type of fabric that you can create using the Virtual Fabrics suite of features.

### NOTE

SNMPv3 is required to manage Virtual Fabrics.

## Logical switch overview

Traditionally, each switch and all the ports in the switch act as a single Fibre Channel switch (FC switch) that participates in a single fabric. The logical switch feature allows you to divide a physical chassis into multiple fabric elements. Each of these fabric elements is referred to as a *logical switch*. Each logical switch functions as an independent self-contained FC switch.

**NOTE**

Each chassis can have multiple logical switches.

## Default logical switch

To use the Virtual Fabrics features, you must first enable Virtual Fabrics on the switch. Enabling Virtual Fabrics creates a single logical switch in the physical chassis. This logical switch is called the *default logical switch*.

The default logical switch initially contains all of the ports in the physical chassis.

The following figure shows a switch before and after enabling Virtual Fabrics. In this example, the switch has 10 ports, labeled P0 through P9.

FIGURE 17 Switch before and after enabling Virtual Fabrics

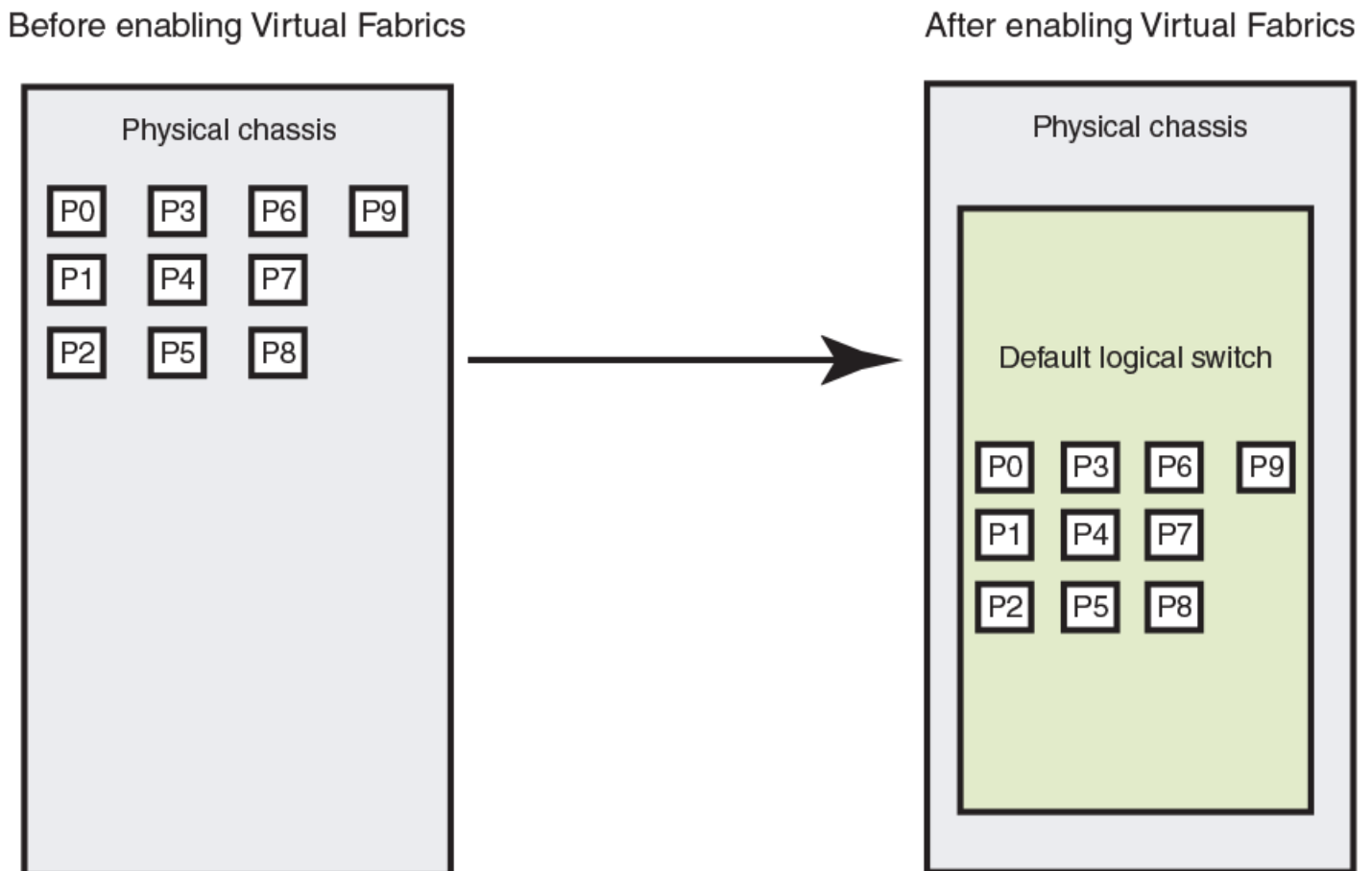



After you enable Virtual Fabrics, you can create up to seven additional logical switches, depending on the switch model.

The following figure shows a Virtual Fabrics-enabled switch before and after it is divided into logical switches. Before you create logical switches, the chassis appears as a single switch (default logical switch). After you create logical switches, the chassis appears as multiple independent logical switches. All of the ports continue to belong to the default logical switch until you explicitly move them to other logical switches.

The default logical switch always exists. You can add and delete other logical switches, but you cannot delete the default logical switch unless you disable Virtual Fabrics.

**FIGURE 18** Switch before and after creating logical switches

**Before logical switch creation**

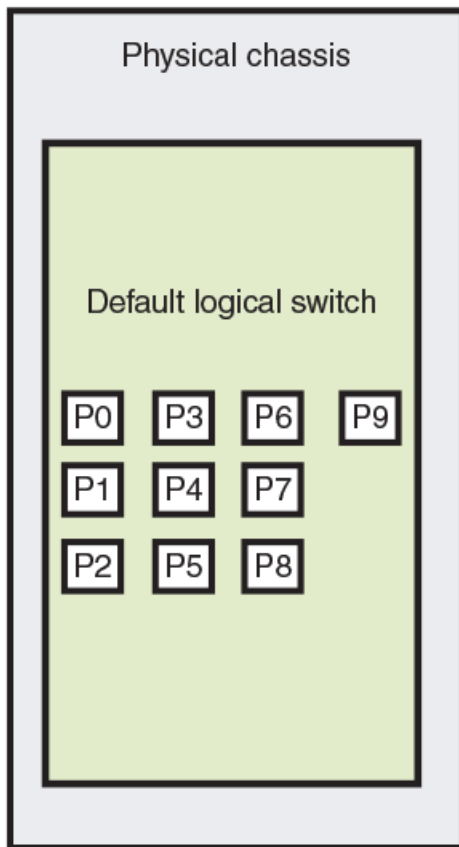

**After logical switch creation**

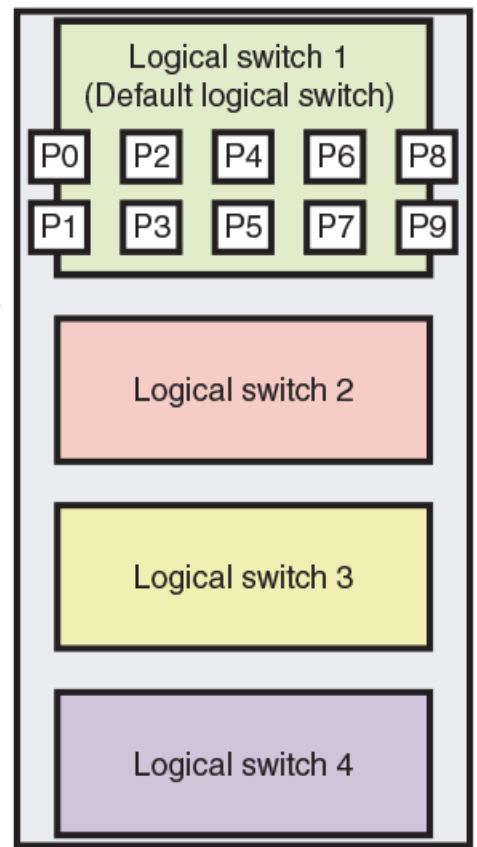

**Logical switches and fabric IDs**

When you create a logical switch, you must assign it a fabric ID (FID). The fabric ID uniquely identifies each logical switch within a chassis and indicates to which fabric the logical switch belongs. You cannot define multiple logical switches with the same fabric ID within the chassis.

In the following figure, logical switches 2, 3, 4, and 5 are assigned FIDs of 1, 15, 8, and 20, respectively. These logical switches belong to different fabrics, even though they are in the same physical chassis. For example, you could not assign logical switch 5 a fabric ID of 15, because logical switch 3 is already assigned FID 15 in the chassis.

The default logical switch is initially assigned FID 128. You can change this value later.

#### NOTE

Each logical switch is assigned one and only one FID. The FID identifies the logical fabric to which the logical switch belongs.

**FIGURE 19** Fabric IDs assigned to logical switches

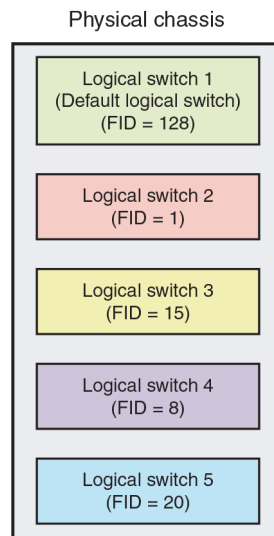

## Port assignment in logical switches

Initially, all ports belong to the default logical switch. When you create additional logical switches, they are empty and you must assign ports to those logical switches.

As you assign ports to a logical switch, the ports are moved from the default logical switch to the newly created logical switch. A given port can be in only one logical switch.

In the following figure, the default logical switch initially has 10 ports, labeled P0 through P9. After logical switches are created, the ports are assigned to specific logical switches. Note that ports 0, 1, 7, and 8 have not been assigned to a logical switch and so remain assigned to the default logical switch.

FIGURE 20 Assigning ports to logical switches

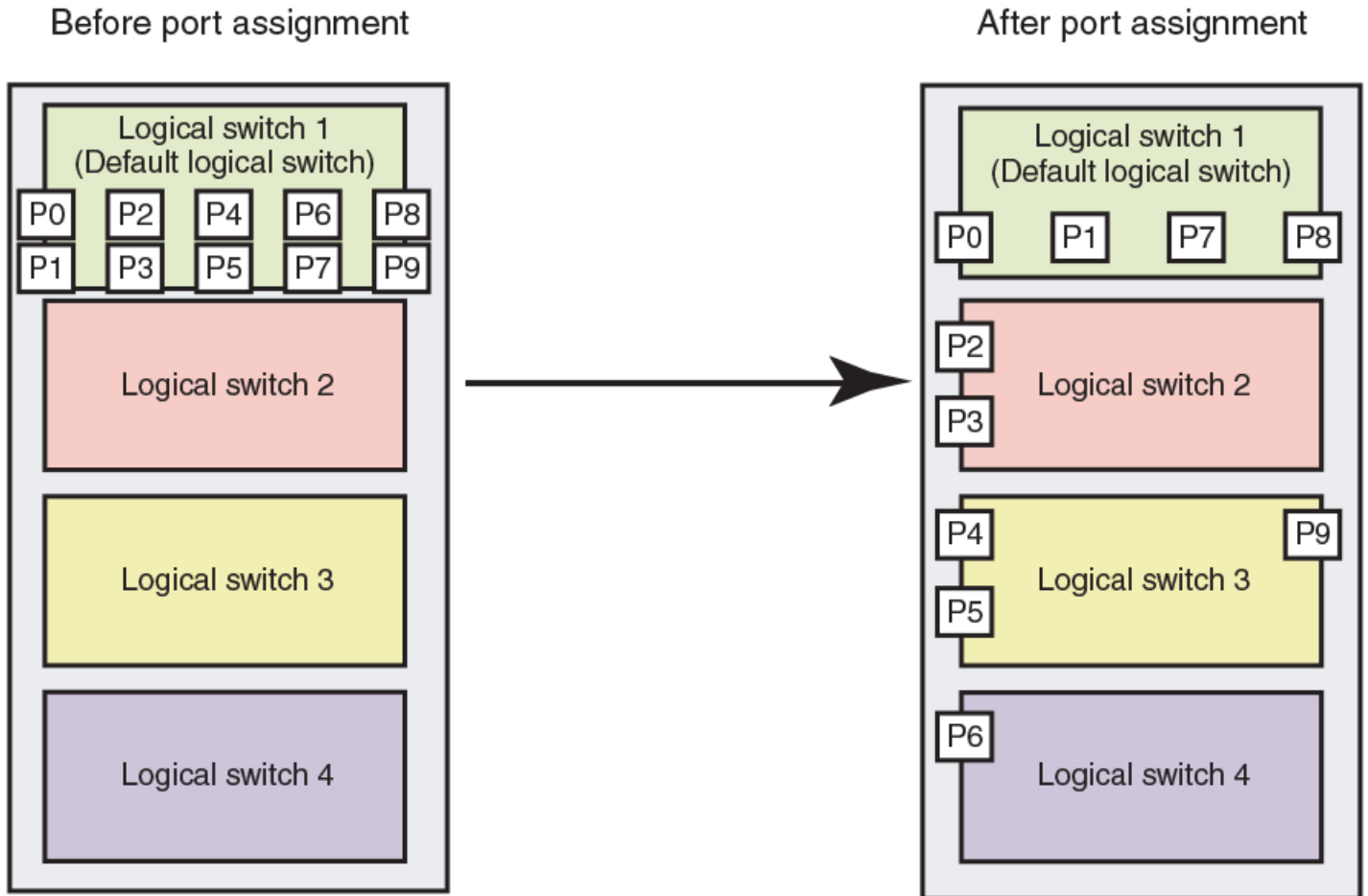

A given port is always in one (and only one) logical switch. The following scenarios refer to the chassis after port assignment in [Figure 20](#):

- If you assign P2 to logical switch 2, you cannot assign P2 to any other logical switch.
- If you want to remove a port from a logical switch, you cannot delete it from the logical switch, but must move it to a different logical switch. For example, if you want to remove P4 from logical switch 3, you must assign it to a different logical switch: logical switch 2, logical switch 4, or logical switch 1 (the default logical switch).
- If you assign a port to a logical switch, it is removed automatically from the logical switch it is currently in. If you assign P3 to Logical switch 3, P3 is automatically removed from logical switch 2.
- If you do not assign a port to any logical switch, it remains in the default logical switch, as is the case with ports 0, 1, 7, and 8.

Refer to [Adding and moving ports on a logical switch](#) on page 289 for instructions for assigning and moving ports on logical switches.

A logical switch can have as many ports as are available in the chassis. In [Figure 20](#), the chassis has 10 ports. You could assign all 10 ports to a single logical switch, such as logical switch 2; if you did this, however, no ports would be available for logical switches 3 and 4.

You can move only F\_Ports and E\_Ports from one logical switch to another. If you want to configure a different type of port, such as a VE\_Port or EX\_Port, you must configure them after you move them. Some types of ports cannot be moved from the default logical switch. Refer to [Supported platforms for Virtual Fabrics](#) on page 281 for detailed information about these ports.

### Logical switches and connected devices

You can connect devices to logical switches, as shown in [Figure 21](#). In logical switch 2, P2 is an F\_Port that is connected to H1. In logical switch 3, P4 is an F\_Port that is connected to D1. H1 and D1 cannot communicate with each other because they are in different fabrics, even though they are both connected to the same physical chassis.

You can also connect other switches to logical switches. In [Figure 21](#), P6 is an E\_Port that forms an inter-switch link (ISL) between logical switch 4 and the non-Virtual Fabrics switch. Logical switch 4 is the only logical switch that can communicate with the non-Virtual Fabrics switch and D2, because the other logical switches are in different fabrics.

FIGURE 21 Logical switches connected to devices and non-Virtual Fabrics switch

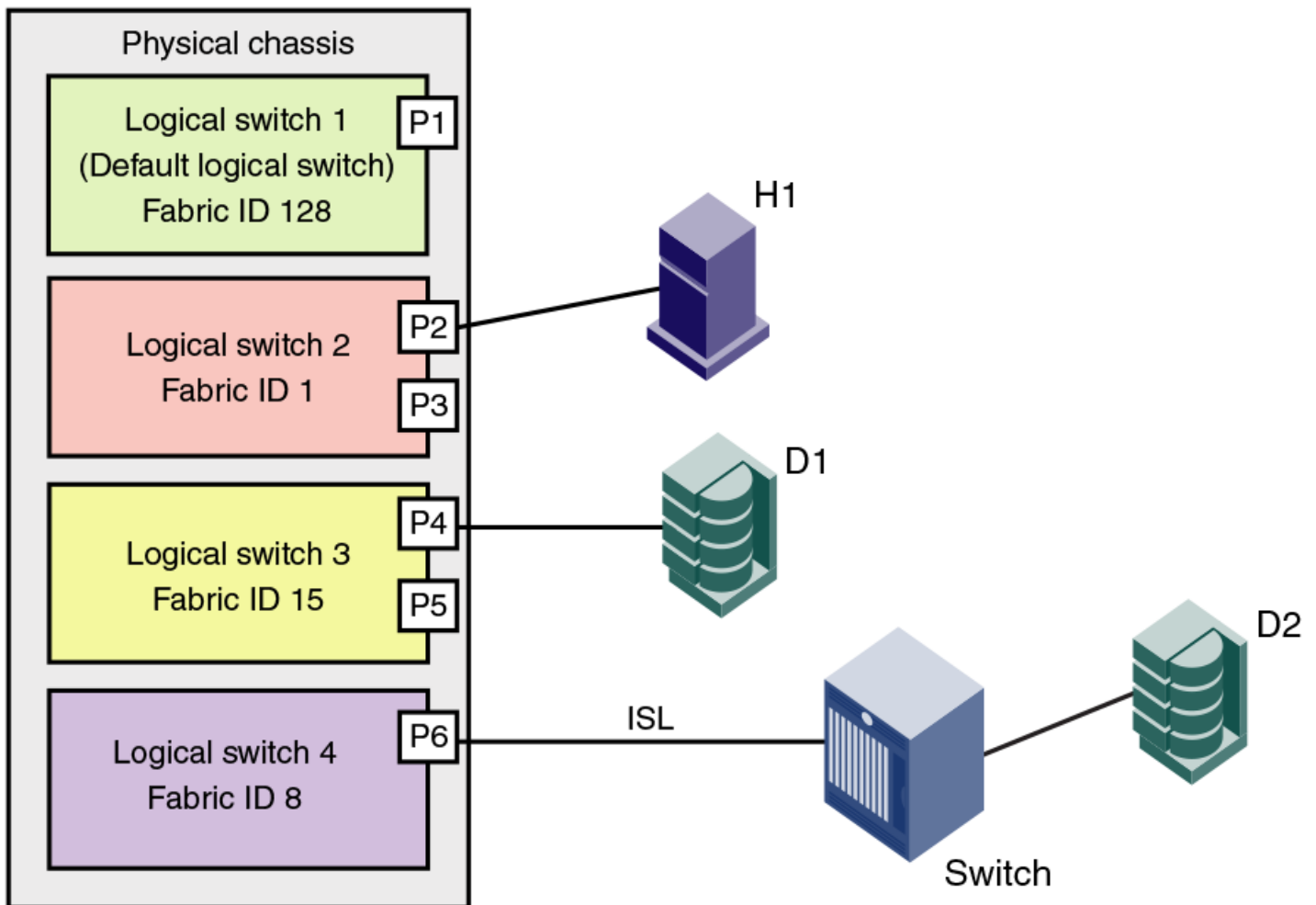
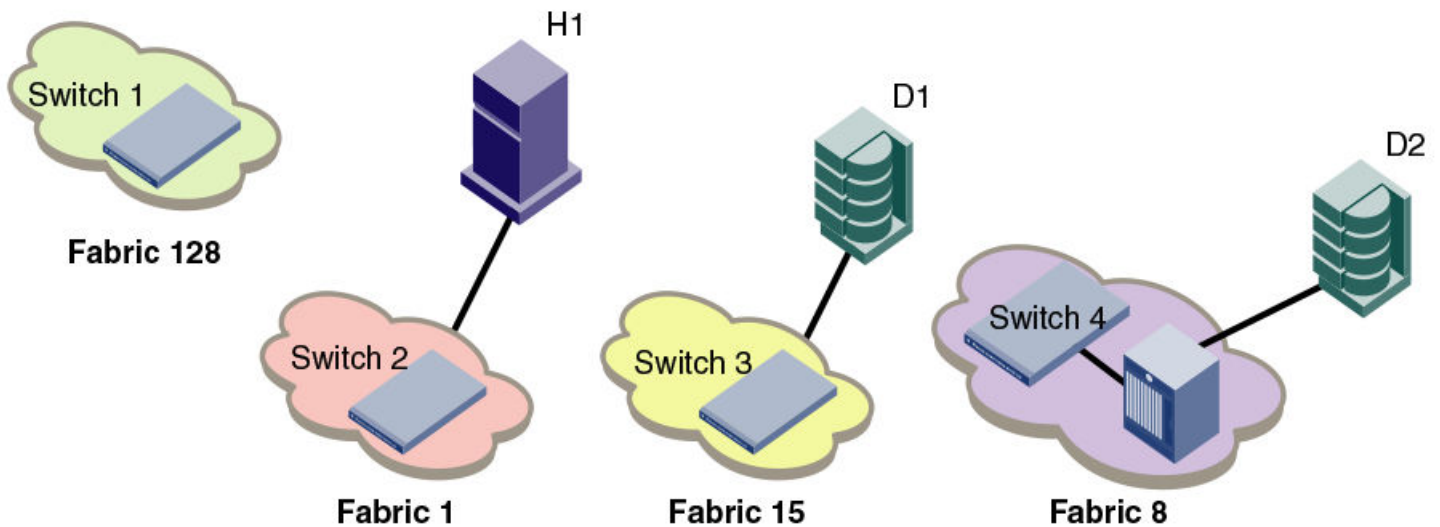

Figure 22 shows a logical representation of the physical chassis and devices in Figure 21. As shown in Figure 22, the devices are isolated into separate fabrics.

FIGURE 22 Logical switches in a single chassis belong to separate fabrics



## Management model for logical switches

The operations you can perform on a logical switch depend on the context you are in. Some operations affect only a single logical switch, and some operations affect the entire physical chassis.

All user operations are classified into one of the following:

- Chassis management operations

These are operations that span logical switch boundaries, such as:

- Logical switch configuration (creating, deleting, or modifying logical switches)
- Account management (determining which accounts can access which logical switches)
- Field-replaceable unit (FRU) management (slot commands, such as **slotShow**)
- Firmware management (firmware upgrade, HA failover)

- Logical switch operations

These are operations that are limited to the logical switch, such as displaying or changing port states. Logical switch operations include all operations that are not covered in the chassis management operations.

When you log in, you are assigned an active context, or active logical switch. This context filters the view that you get, and determines which ports you can see. You can change the active context. For example, if you are working with logical switch 1, you can change the context to logical switch 5. When you change the context to logical switch 5, you only see the ports that are assigned to that logical switch. You do not see any of the other ports in the chassis.

The scope of logical switch operations is defined by the active context. When you are in the context of a logical switch, you can perform port, switch, and fabric-level operations, subject to Role-Based Access Control (RBAC) rules.

If you have permission to execute chassis-level commands, you can do so, regardless of which logical switch context you are in.

## Logical fabric overview

A *logical fabric* is a fabric that contains at least one logical switch.

The four fabrics shown in [Figure 21](#) on page 272 and [Figure 22](#) on page 273 are logical fabrics because they each have at least one logical switch.

You can connect logical switches to non-Virtual Fabrics switches and to other logical switches. You connect logical switches to non-Virtual Fabrics switches using an ISL, as shown in [Figure 21](#) on page 272.

You connect logical switches to other logical switches in two ways:

- Using ISLs
- Using base switches and extended ISLs (XISLs)

## Logical fabric and ISLs

[Figure 23](#) shows two physical chassis divided into logical switches. In [Figure 23](#), ISLs are used to connect the logical switches with FID 1 and the logical switches with FID 15. The logical switches with FID 8 are each connected to a non-Virtual Fabrics switch. The two logical switches and the non-Virtual Fabrics switch are all in the same fabric, with FID 8.

FIGURE 23 Logical switches connected to other logical switches through physical ISLs

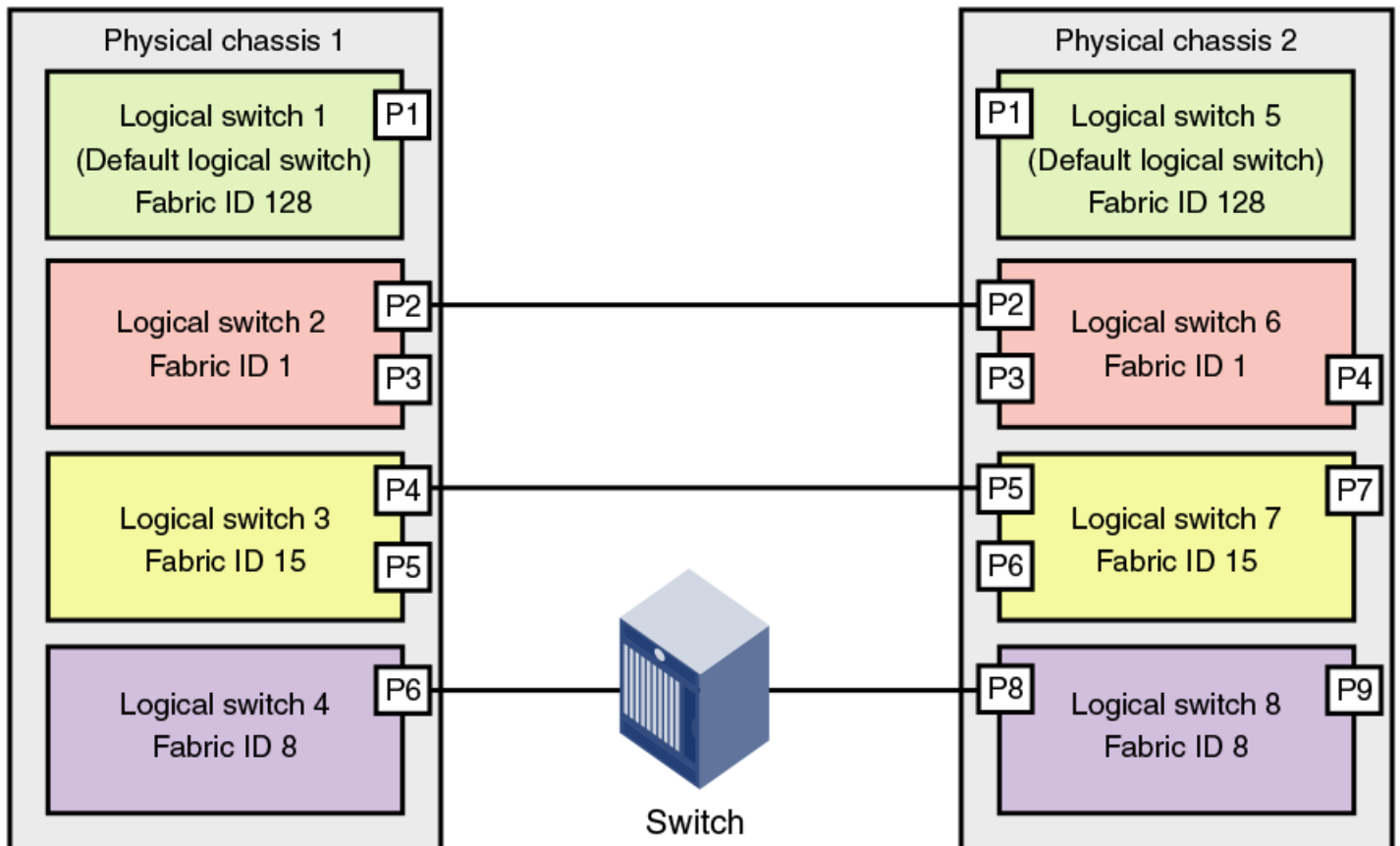
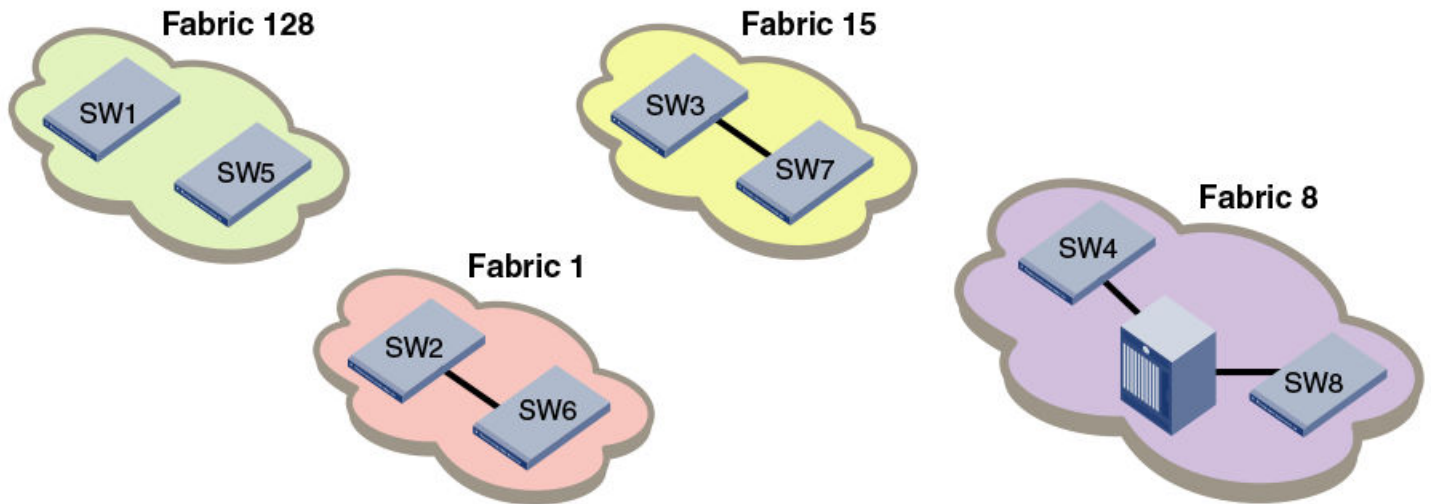

Figure 24 shows a logical representation of the configuration in Figure 23.

FIGURE 24 Logical switches connected to form logical fabrics



The ISLs between the logical switches are *dedicated ISLs* because they carry traffic only for a single logical fabric. In Figure 23, Fabric 128 has two switches (the default logical switches), but they cannot communicate with each other because they have no ISLs between them and they cannot use the ISLs between the other logical switches.

#### NOTE

Only logical switches with the same FID can form a fabric. If you connect two logical switches with different FIDs, the link between the switches segments.

## Base switch and extended ISLs

One way to connect logical switches is to use extended ISLs and base switches.

When you divide a chassis into logical switches, you can designate one of the switches to be a base switch. A *base switch* is a special logical switch that is used for interconnecting the physical chassis.

A base switch has the following properties:

- ISLs connected through the base switch can be used for communication among the other logical switches.
- Base switches do not support direct device connectivity. A base switch can have only E\_Ports, VE\_Ports, EX\_Ports, or VEX\_Ports, but no F\_Ports.
- The base switch provides a common address space for communication between different logical fabrics.
- A base switch can be configured for the preferred domain ID just like a non-Virtual Fabrics switch.
- You can have only one base switch in a physical chassis.

A base switch can be connected to other base switches through a special ISL, called a *shared ISL* or *extended ISL* (XISL). An extended ISL connects base switches. The XISL is used to share traffic among different logical fabrics.

Fabric formation across an XISL is based on the FIDs of the logical switches.

Figure 25 shows two physical chassis divided into logical switches. Each chassis has one base switch. An ISL connects the two base switches. This ISL is an extended ISL (XISL) because it connects base switches.

FIGURE 25 Base switches connected by an XISL

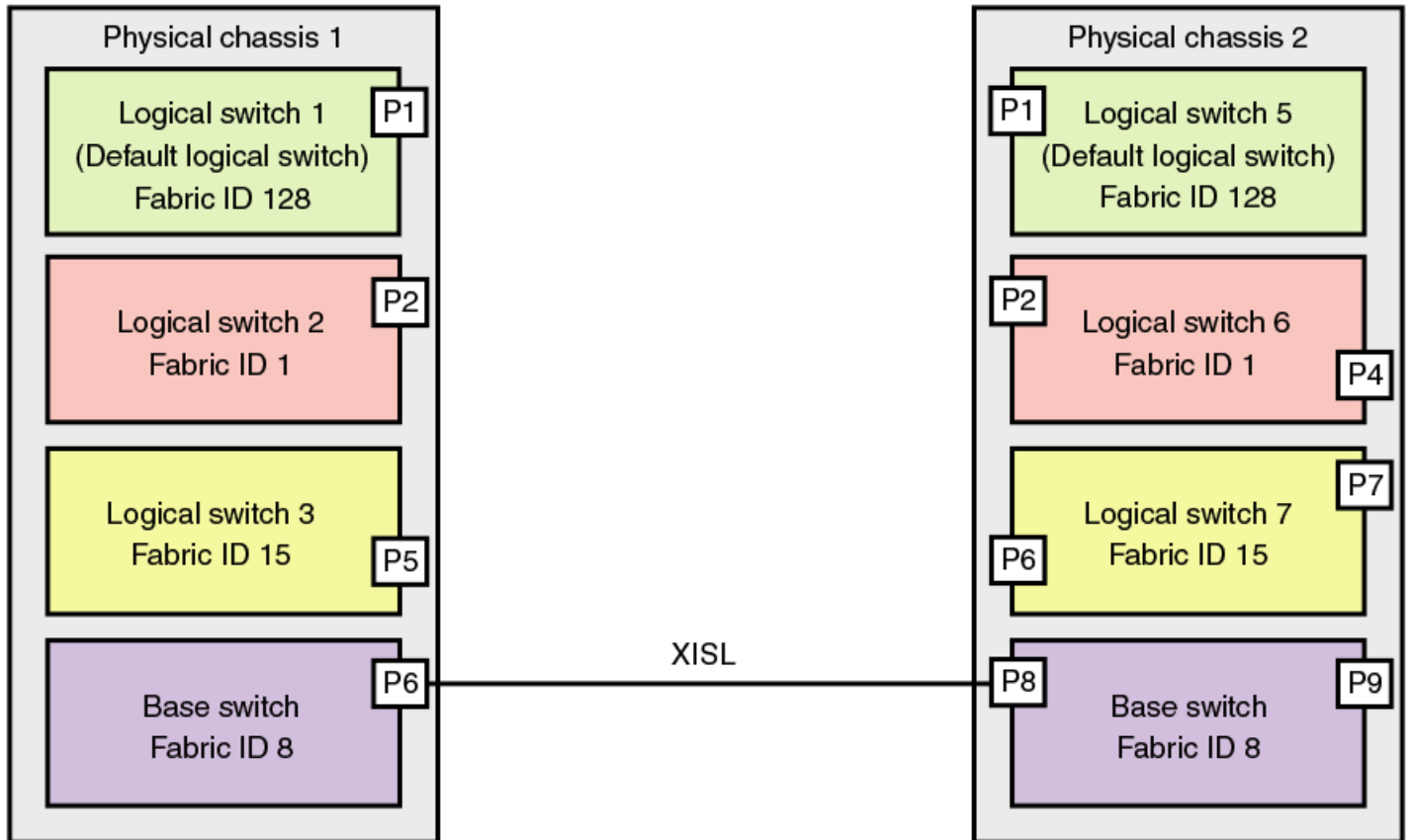

Traffic between the logical switches can now flow across this XISL. The traffic can flow only between logical switches with the same fabric ID. For example, traffic can flow between logical switch 2 in chassis 1 and logical switch 6 in chassis 2, because they both have FID 1. Traffic cannot flow between logical switch 2 and logical switch 7, because they have different fabric IDs (and are thus in different fabrics).

Think of the logical switches as being connected with logical ISLs, as shown in Figure 26. In this diagram, the logical ISLs are not connected to ports because they are not physical cables. They are a logical representation of the switch connections that are allowed by the XISL.



FIGURE 26 Logical ISLs connecting logical switches

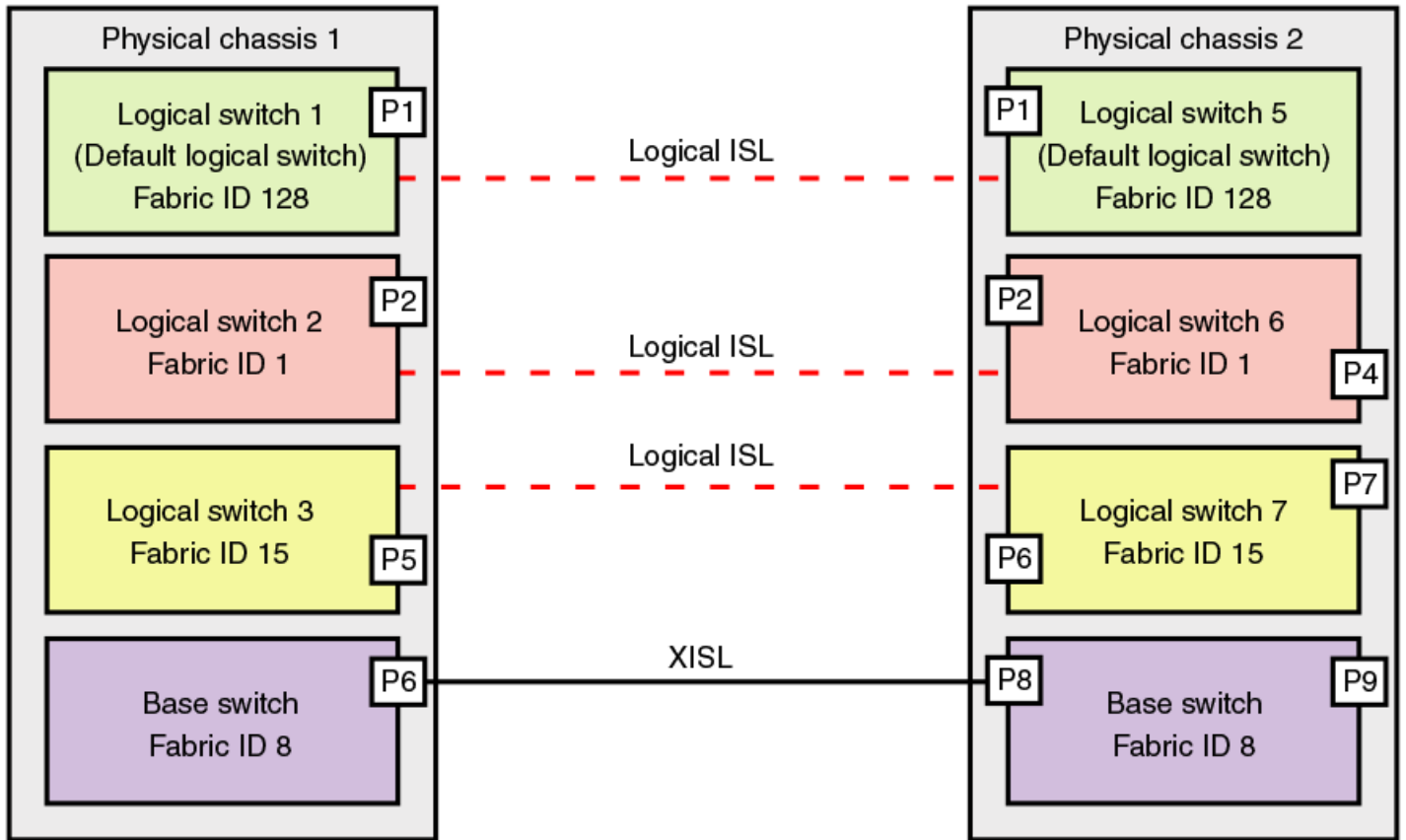

To use the XISL, the logical switches must be configured to allow XISL use. By default, they are configured to do so; you can change this setting, however, using the procedure described in [Configuring a logical switch for XISL use](#) on page 292.

**NOTE**

It is a good practice to configure at least two XISLs, for redundancy.

You can also connect logical switches using a combination of ISLs and XISLs, as shown in [Figure 27](#). In this diagram, traffic between the logical switches in FID 1 can travel over either the ISL or the XISL. Traffic between the other logical switches travels only over the XISL.

FIGURE 27 Logical fabric using ISLs and XISLs

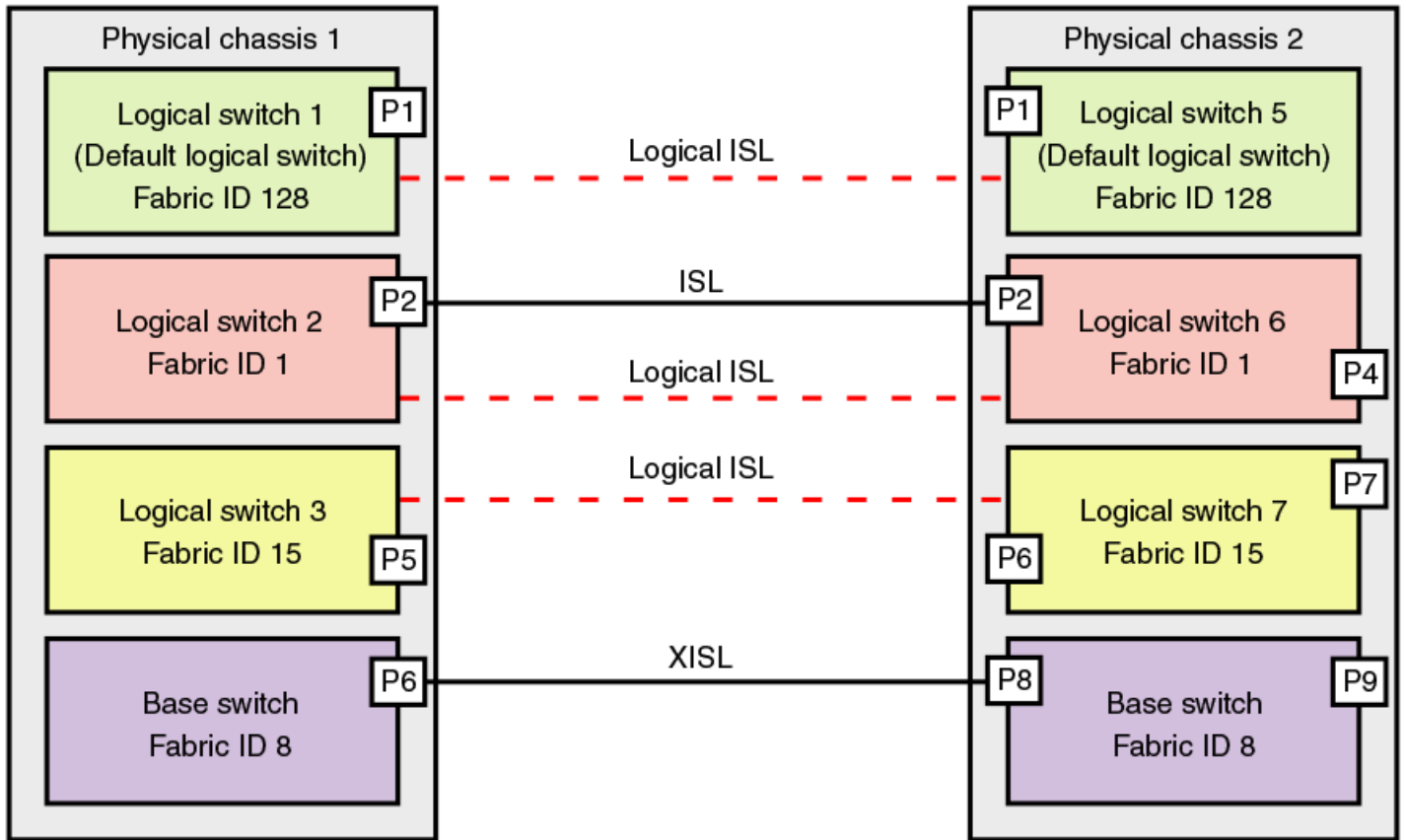

By default, the physical ISL path is favored over the logical path (over the XISL) because the physical path has a lower cost. This behavior can be changed by configuring the cost of the dedicated physical ISL to match the cost of the logical ISL.

**ATTENTION**

If you disable a base switch, all of the logical ISLs are broken and the logical switches cannot communicate with each other unless they are connected by a physical ISL.

**Base fabric**

Base switch ports on different chassis can be connected together to form a fabric, called a *base fabric*. Similar to other logical switches, the base switches must have the same FID to be connected. If the base switches have different FIDs, the link between the switches is disabled.

The base fabric follows normal routing policies. As long as physical connectivity is available, the base fabric maintains connectivity for the logical fabrics.

**Logical ports**

As shown in Figure 27 on page 278, logical ISLs are formed to connect logical switches. A *logical port* represents the ports at each end of a logical ISL. A logical port is a software construct only and does not correspond to any physical port.

Most port commands are not supported on logical ports. For example, you cannot change the state or configuration of a logical port. However, state change on a logical link is permitted using the `lfcfg --lisEnable` command.

The World Wide Name (WWN) for logical ports is in NAA=5 format, using the following syntax:

```
5n:nn:nn:nz:zz:zz:zx:xx
```

The NAA=5 syntax uses the following variables:

- `nnnnnn` is the Brocade Organizationally Unique Identifier (OUI).
- `zzzzzz` is the logical fabric serial number.
- `xxx` is the logical port number, in the range 0 through FFF.

## Logical fabric formation

Fabric formation is not based on connectivity, but on the FIDs of the logical switches. The basic order of fabric formation is as follows:

1. Base fabric forms.
2. Logical fabrics form when the base fabric is stable.
3. Devices begin recognizing one another.
4. Traffic is initiated between the logical switches.

## Account management and Virtual Fabrics

When user accounts are created, they are assigned a list of logical fabrics to which they can log in and a home logical fabric (home FID). When you connect to a physical chassis, the home FID defines the logical switch to which you are logged in by default. You can change to a different logical switch context, as described in [Changing the context to a different logical fabric](#) on page 293.

When you are logged in to a logical switch, the system prompt changes to display the FID of that switch. The following are example prompts for when you are logged in to the default logical switch (FID = 128) and a user-defined logical switch (FID = 15):

```
switch:FID128:admin>
switch:FID15:admin>
```

Refer to [Managing User Accounts](#) on page 145 for information about creating user accounts and assigning FIDs to user accounts.

## Setting up IP addresses for a logical switch

Each physical chassis has one common IP address that is shared by all of the logical switches in the chassis. You can set up individual IPv4 addresses for each logical switch.

IPv4 addresses assigned to individual logical switches are assigned to IP over Fibre Channel (IPFC) network interfaces. In Virtual Fabrics environments, a single chassis can be assigned to multiple fabrics, each of which is logically distinct and separate from one another. Each IPFC point of connection to a given chassis needs a separate IPv4 address and prefix to be accessible to a management host.

For a management host to access logical switches, the host bus adapter (HBA) must be able to connect with the common, shared IP address and the individual IPv4 addresses configured for each logical switch.

### NOTE

IPv6 is not supported when setting the IPFC interface for Virtual Fabrics.

IPFC addresses are not handled by `configupload` or `configdownload`. The IPFC address of the default logical switch or a non-VF switch is stored on the WWN card or compact flash. This address does not display in a `configshow`. Non-default logical switch IPFC addresses display in a `configshow`. The `ipaddrshow` command displays all switch addresses and IPFC addresses configured in the chassis.

Use the following procedure to set up IP addresses for a logical switch:

1. Connect to the switch and log in using an account with admin permissions.
2. Enter the **ipAddrSet -ls** command.
  - To add an IPv4 address, use the **--add** parameter. Specify the network information in dotted-decimal notation for the Ethernet IPv4 address with a Classless Inter-Domain Routing (CIDR) prefix.
  - To delete an IPv4 address, use the **--delete** parameter.
3. Enter the **ipaddrshow** command to verify the result.

The following example sets IP addresses with the CIDR prefix for logical switches with FID 1, 2, and 128 (default logical switch).

```
switch:FID128:admin> ipaddrset -ls 1 --add 192.0.2.11/24
IP address is being changed...Done.
switch:FID128:admin> ipaddrset -ls 2 --add 192.0.2.22/24
IP address is being changed...Done.
switch:FID128:admin> ipaddrset -ls 128 --add 192.0.2.0/24
IP address is being changed...Done.

switch:FID128:admin> ipaddrshow

SWITCH
Ethernet IP Address: 198.51.100.0
Ethernet Subnetmask: 255.255.255.0
Gateway IP Address: 198.51.100.1
DHCP: Off
IPFC address for virtual fabric ID 128: 192.0.2.0/124
IPFC address for virtual fabric ID 1: 192.0.2.11/24
IPFC address for virtual fabric ID 2: 192.0.2.22/24
```

The following example deletes the IP address for the logical switch with FID 1.

```
switch:FID128:admin> ipaddrset -ls 1 --delete
```

## Logical switch login context

When you log in to a logical switch with Telnet or SSH, the login shell uses the destination IPFC address to look up and set the corresponding logical switch context. When you log in from the serial console, the login shell always sets your default home logical switch context. The IPFC assigned to a logical switch is managed by the **ipAddrSet** command that was supported in releases prior to Fabric OS 7.4.0. When you use Telnet or SSH from a remote host, the IPFC address must share the same network (netmask) as the management interface. The values of FCIP addresses and subnet masks are stored in the WWN card. For example, if the management interface IP address is 10.38.18.183 with netmask 255.255.240.0, you can create the IPFC address using the following command.

```
ipaddrset -ls 8 --add 10.38.18.183/20
```

### NOTE

The logical switch login context supersedes the default FID context of a user.

To delete the IPFC address, you can use the following command.

```
ipaddrset -ls 8 --delete
```

If you log in to a switch with the management interface IP address, the home virtual fabric is set for the context. You can log in to the logical switch context by using the Telnet or SSH service with the configured IPFC address. You can manage the permissions using the **userConfig** command.

```
switch> userconfig --show admin
Account name: admin
Description: Administrator
Enabled: Yes
Password Last Change Date: Unknown (UTC)
```

```

Password Expiration Date: Not Applicable (UTC)
Locked: No
Home LF Role: admin
Role-LF List: admin: 1-128
Chassis Role: admin
Home LF: 128
Day Time Access: N/A

```

*Role-LF* is the list of logical switch contexts for which you have permission to log in over the IPFC address. *Home LF Role* is the default logical switch context when you have no permission to log in to a particular logical switch context or over management interface. The following output shows the result of the **ipAddrShow** command. There is only one IPFC mapped to FID 8.

```

switch> ipaddrshow
SWITCH
Ethernet IP Address: 10.38.18.183
Ethernet Subnetmask: 255.255.240.0
Gateway IP Address: 10.38.16.1
DHCP: Off
IPFC address for virtual fabric ID 8: 10.38.18.183/20

```

The following conditions apply for default users:

- For admin and root users, the login is successful to the given logical switch with the corresponding logical switch context set (FID 1-128). When you telnet to IPFC 10.38.18.183, the context is set to FID 8.
- For the user privilege, you are allowed to log in to the home virtual fabric (FID 128) only. Direct login is not allowed to the corresponding logical switch context. When you telnet to IPFC 10.38.18.183, the context is set to FID 128.

The following conditions apply for non-default users:

- For non-default users configured in the switch with or without the logical switch permission, if the user logs in with the IPFC address without the permission for the corresponding logical switch, only the default home virtual fabric of the user is set for the context.
- For non-default users configured in the switch with or without the logical switch permission, if the user logs in with the IPFC address with the permission for the corresponding logical switch, login is successful to the given logical switch with the corresponding logical switch context set.

## Supported platforms for Virtual Fabrics

The following platforms are Virtual Fabrics-capable:

- Brocade 6510
- Brocade 6520
- Brocade G620
- Brocade 7840
- Brocade DCX 8510 family
- Brocade X6 family

Some restrictions apply to the ports, depending on the port type and blade type. The following sections explain these restrictions.

## Supported port configurations in the fixed-port switches

There are no restrictions on the ports in Brocade 6510, 6520, or G620 devices.

The following rules apply:

- Any port can belong to any logical switch (including the base switch and default logical switch), with the exception that F\_Ports cannot belong to the base switch.

- The default logical switch can use XISLs, *except* on Brocade Backbone family devices.
- The default logical switch can also be a base switch except on Brocade 8510 Backbones and X6 Directors.

For the Brocade 7840, the following rules apply:

- A base switch is supported on the Brocade 7840 starting with Fabric OS 7.4.0.
- XISL is supported on the Brocade 7840 starting with Fabric OS 7.4.0.

## Supported port configurations in Brocade Backbones and Directors

Some of the ports in the Brocade DCX 8510 Backbones and X6 Directors are not supported on all types of logical switches. The following table lists the blades and ports that are supported on each type of logical switch.

**TABLE 59** Blade and port types supported on logical switches

Blade type	Default logical switch	User-defined logical switch	Base switch
FC16-32	Yes (F, E)	Yes (F, E)	Yes (E, EX)
FC16-48			
FC32-48			
FC16-64	Yes (F, E)	Yes (F, E)	Yes (E, EX)
SX6: FC ports	Yes (F, E)	Yes (F, E)	Yes (E, EX)
GE ports	Yes (VE)	Yes (VE)	Yes (VE, VEX)
FX8-24: FC ports	Yes (F, E)	Yes (F, E)	Yes (E, EX)
GE ports	Yes (VE)	Yes (VE)	Yes (VE, VEX)
ICL ports	Yes (E)	Yes (E)	Yes (E, EX)

## Restrictions on Brocade Backbones

The following restrictions apply to Brocade Backbones:

- EX\_Ports and VEX\_Ports can be in only the base switch.
- ICL ports cannot be in a logical switch that is using XISLs.
- All of the user ports in an ICL cable must be in the same logical switch. Distributing the user ports within the same cable across multiple logical switches is not supported.
- ICL ports that are configured as EX\_Ports can be in only the base switch.
- The default logical switch cannot use XISLs.
- The default logical switch cannot be designated as the base switch.
- In Fabric OS v7.0.0 and later, VE\_Ports on the FX8-24 blade are supported on a logical switch that is using an XISL, and on the base switch as an XISL.

### NOTE

For the FX8-24 blade, if XISL use is enabled it is not recommended that you configure VE\_Ports on both the logical switch and the base switch, because FCIP tunnels support only two hops maximum.

## Virtual Fabrics interaction with other Fabric OS features

The following table lists some Fabric OS features and considerations that apply when using Virtual Fabrics.

**TABLE 60** Virtual Fabrics interaction with Fabric OS features

Fabric OS feature	Virtual Fabrics interaction
Access Gateway	Virtual Fabrics is not supported on a switch if AG mode is enabled.
Configuration upload and download	Virtual Fabrics uses a configuration file that is different from the configuration file used to download system configuration parameters. Refer to <a href="#">Maintaining the Switch Configuration File</a> on page 257 for more information about how Virtual Fabrics affects the configuration file.
Encryption	Encryption functionality using the FS8-18 blade is available only on the default logical switch.
FC-FC Routing Service	All EX_Ports must reside in a base switch.  You cannot attach EX_Ports to a logical switch that has XISL use enabled. You must use ISLs to connect the logical switches in an edge fabric.  Refer to <a href="#">Using FC-FC Routing to Connect Fabrics</a> on page 489 for more information about Virtual Fabrics and FC-FC routing.
FICON	Up to two logical switches per chassis can run FICON Management Server (CUP), but the FICON logical switch can use both ISLs and XISLs.
ISL R_RDY mode	ISL R_RDY mode is not supported in a base switch.
Licensing	Licenses are applicable for all logical switches in a chassis.
Network time protocol (NTP)	The clock information for a chassis is maintained by the default logical switch and not from the principal or primary FCS switch. Refer to <a href="#">Network Time Protocol</a> on page 59 for more information about how Virtual Fabrics affects NTP.
QoS	QoS VCs are maintained across the base fabric. Refer to <a href="#">Optimizing Fabric Behavior</a> on page 387 for more information about using the Adaptive Networking features with Virtual Fabrics.
Traffic Isolation	Traffic Isolation with Failover-Disabled (TI FD) zoning is not supported over LISLs; Traffic Isolation zones with Failover-Enabled (TI FE) is supported. TI FD zoning is supported over DISLs (physical links). TI FD zoning is not supported in the base fabric.  Refer to <a href="#">Optimizing Fabric Behavior</a> on page 387 for additional information about using TI Zones with Virtual Fabrics.

## Limitations and restrictions of Virtual Fabrics

Before you use the Virtual Fabrics feature, you should be aware of the restrictions and limitations regarding QSFP ports and the maximum number of logical switches per chassis.

In the core blades, all four ports belonging to a QSFP must be moved to the same logical switch.

The maximum number of logical switches per chassis varies depending on the switch model. The following table lists the supported platforms and the maximum number of logical switches (including the default logical switch) supported on each.

**TABLE 61** Maximum number of logical switches per chassis

Platform	Maximum number of logical switches
Brocade X6 Directors	8
Brocade DCX 8510 Backbones	8
Brocade 6510	4
Brocade 6520	4
Brocade G620	4
Brocade 7840	4

Refer to [Supported port configurations in Brocade Backbones and Directors](#) on page 282 for restrictions on the default logical switch.

If a blade slot is being decommissioned and has ports configured in logical switches, it is recommended that the logical port assignments be removed from that blade before removing the blade. This ensures a seamless transition for any new port or AP blade that might occupy that slot in the future. This does not apply if you are simply replacing a blade of the same type.

## Restrictions on XISLs

The **Allow XISL Use** option under the **configure** command, allows a logical switch to use XISLs in the base switch as well as any standard ISLs that are connected to that logical switch. To allow or disallow XISL use for a logical switch, see [Configuring a logical switch for XISL use](#) on page 292.

The following restrictions apply to XISL use. XISL use is not permitted in any of the following scenarios:

- The logical switch has ICL ports.
- The logical switch is the default logical switch in the Brocade DCX 8510 or X6 Director family.
- The logical switch is a base switch.
- The logical switch is an edge switch for an FC router.

In this case, if the logical switch is enabled, you cannot allow XISL use. If the logical switch is disabled or has not yet joined the edge fabric, you *can* allow XISL use; however, fabric segmentation occurs when the logical switch is enabled or connected to an edge fabric.

### NOTE

Using XISL and `fmsmode` at the same time is permitted, but this combination will only work in a one-hop topology.

## Restrictions on moving ports

The following are restrictions on moving ports among logical switches:

- FC ports cannot be moved if any one of the following features is enabled:
  - Long distance
  - QoS
  - F\_Port buffers
  - F\_Port trunking
  - E\_Port credits
  - SIM\_Port
- Before moving VE\_Ports, you must remove the VE\_Port tunnel configuration.
- VE\_Ports on the FX8-24 or SX6 blade can be moved to any logical switch independent of the location of the physical GE port.
- If you move existing EX\_Ports or VEX\_Ports to any logical switch other than the base switch, these ports are automatically disabled.

## Enabling Virtual Fabrics mode

A fabric is said to be in *Virtual Fabrics mode* (VF mode) when the Virtual Fabrics feature is enabled. Before you can use the Virtual Fabrics features, such as logical switch and logical fabric, you must enable VF mode.

VF mode is enabled by default.

### NOTE

When you enable VF mode, the control processors (CPs) are rebooted and all EX\_Ports are disabled after the reboot.



1. Connect to the physical chassis and log in using an account with the chassis-role permission.
2. Use the **fosConfig** command to check whether VF mode is enabled:

```
fosconfig --show
```

3. Use the **fosConfig** command to enable VF mode:

```
fosconfig --enable vf
```

4. Enter **y** at the prompt.

The following example checks whether VF mode is enabled or disabled and then enables it.

```
switch:admin> fosconfig --show
FC Routing service:           disabled
iSCSI service:                Service not supported on this Platform
iSNS client service:          Service not supported on this Platform
Virtual Fabric:               disabled
Ethernet Switch Service:      Service not supported on this Platform

switch:admin> fosconfig --enable vf
WARNING: This is a disruptive operation that requires a reboot to take effect.
All EX ports will be disabled upon reboot.
Would you like to continue [Y/N] y
VF has been enabled. Your system is being rebooted.
```

## Disabling Virtual Fabrics mode

When you disable VF mode, the following occurs:

- The CPs are rebooted.
  - If F\_Port trunking is enabled on ports in the default switch, the F\_Port trunking information is preserved.
1. Connect to the physical chassis and log in using an account with the chassis-role permission.
  2. Use the **fosConfig** command to check whether VF mode is disabled:

```
fosconfig --show
```

3. Move all ports to the default logical switch.

```
lscfg --config 128 -slot slot -port port
```

4. Delete all of the non-default logical switches.

```
lscfg --delete fabricID
```

5. Use the **fosConfig** command to disable VF mode:

```
fosconfig --disable vf
```

6. Enter **y** at the prompt.

The following example checks whether VF mode is enabled or disabled and then disables it.

```
switchA:FID128:admin> fosconfig --show

FC Routing service:           disabled
iSCSI service:               Service not supported on this Platform
iSNS client service:         Service not supported on this Platform
Virtual Fabric:              enabled
Ethernet Switch Service      Service not supported on this Platform

switch:admin> fosconfig --disable vf
WARNING: This is a disruptive operation that requires a reboot to take effect.
Would you like to continue [Y/N] y
```

## Configuring logical switches to use basic configuration values

All switches in the fabric are configured to use the same basic configuration values. When you create logical switches, the logical switches might have different configuration values than the default logical switch. Use the following procedure to ensure that newly created logical switches have the same basic configuration values as the default logical switch.

### NOTE

For most users, you do not need to run this procedure. Contact your switch service provider to determine if you need to use this procedure.

You need to run this procedure only once on each chassis, after you enable Virtual Fabrics but before you create logical switches. The configuration settings are then preserved across reboots and firmware upgrades and downgrades.

Use the following procedure to configure logical switches to use basic configuration values:

1. Connect to the physical chassis and log in using an account with the chassis-role permission.
2. Enter the **configureChassis** command to ensure that newly created logical switches have the same basic configuration values as the default logical switch:

```
configurechassis
```

3. Enter **n** at the prompts to configure system and cfgload attributes. Enter **y** at the prompt to configure custom attributes.

```
System (yes, y, no, n): [no] n
cfgload attributes (yes, y, no, n): [no] n
Custom attributes (yes, y, no, n): [no] y
```

4. Enter the appropriate value at the Config Index prompt. Contact your switch service provider to determine the appropriate value.

```
Config Index (0 to ignore): (0..1000) [3]:
```

## Creating a logical switch or base switch

When a logical switch is created, it is automatically enabled and is empty--that is, it does not have any ports. After creating the logical switch, you must disable the switch to configure it and set the domain ID. You then assign ports to the logical switch.

You can optionally define the logical switch to be a base switch. Each chassis can have only one base switch.

### NOTE

Domain ID conflicts are detected before fabric ID conflicts. If you have both a domain ID conflict and a fabric ID conflict, only the domain ID conflict is reported.

1. Connect to the physical chassis and log in using an account with the chassis-role permission.
2. Enter the **lsCfg** command to create a logical switch:

```
lscfg --create fabricID [ -base ]
```

In the command syntax, *fabricID* is the fabric ID that is to be associated with the logical switch.

Specify the **-base** option if the logical switch is to be a base switch.

3. Set the context to the new logical switch.

```
setcontext fabricID | switchname
```

The *fabricID* parameter is the FID of the logical switch you just created. The *switchname* parameter is the name assigned to the logical switch. You can only use one parameter at a time.

4. Disable the logical switch.

```
switchdisable
```

5. Configure the switch attributes, including assigning a unique domain ID.

```
configure
```

6. Enable the logical switch.

```
switchenable
```

## Example of creating a logical switch

The following example creates a logical switch with FID 4, and then assigns domain ID 14 to it.

```
sw0:FID128:admin> lscfg --create 4
A Logical switch with FID 4 will be created with default configuration.
Would you like to continue [y/n]?y
About to create switch with fid=4. Please wait...
Logical Switch with FID (4) has been successfully created.
Logical Switch has been created with default configurations.
Please configure the Logical Switch with appropriate switch
and protocol settings before activating the Logical Switch.
sw0:FID128:admin> setcontext 4

switch_4:FID4:admin> switchdisable

switch_4:FID4:admin> configure

Configure...
Fabric parameters (yes, y, no, n): [no] yes
Domain: (1..239) [1] 100
Select Addressing Mode:
(1 = Zero Based Area Assignment,
2 = Port Based Area Assignment): (1..2) [2] 2
WWN Based persistent PID (yes, y, no, n): [no]
(output truncated)
WARNING: The domain ID will be changed. The port level zoning may be affected

switch_4:FID4:admin> switchenable
```

After you create the logical switch, you assign ports to it, as described in [Adding and moving ports on a logical switch](#) on page 289.

## Executing a command in a different logical switch context

If you are in the context of a logical switch, you can execute a command for a different logical switch. You can also execute a command for all of the logical switches in a chassis.

The command is not executed on those logical switches for which you do not have permission.

1. Connect to the physical chassis and log in using an account with the chassis-role permission.
2. Enter one of the following commands:
  - To execute a command in a different logical switch context:

```
fosexec --fid fabricID -cmd "command"
```

- To execute a command on all logical switches:

```
fosexec --fid all -cmd "command"
```

## Executing the switchShow command in a different logical switch context

```
sw0:FID128:admin> fosexec --fid 4 -cmd "switchshow"
-----
"switchshow" on FID 4:
switchName:      switch_4
switchType:      66.1
switchState:     Online
switchMode:      Native
switchRole:      Principal
switchDomain:     14
switchId:        fffc0e
switchWwn:       10:00:00:05:1e:82:3c:2b
zoning:          OFF
switchBeacon:    OFF
FC Router:       OFF
Fabric Name:     Fab4
Allow XISL Use:  ON
LS Attributes:   [FID: 4, Base Switch: No, Default Switch: No, Address Mode 0]
Index Port Address Media Speed State Proto
=====
 22 22 0e1600 -- N8 No_Module FC Disabled
 23 23 0e1700 -- N8 No_Module FC Disabled
```

## Executing the fabricShow command on all logical switches

```
sw0:FID128:admin> fosexec --fid all -cmd "fabricshow"
-----
"fabricshow" on FID 128:
Switch ID  Worldwide Name          Enet IP Addr  FC IP Addr  Name
-----
 97: fffc61 10:00:00:05:1e:82:3c:2a 10.32.79.105 0.0.0.0     >"sw0"
-----
"fabricshow" on FID 4:
Switch ID  Worldwide Name          Enet IP Addr  FC IP Addr  Name
-----
 14: fffc0e 10:00:00:05:1e:82:3c:2b 10.32.79.105 0.0.0.0     >"switch_4"
(output truncated)
```

## Deleting a logical switch

The following rules apply to deleting a logical switch:

- You must remove all ports from the logical switch before deleting it.

- You cannot delete the default logical switch.

#### NOTE

If you are in the context of the logical switch you want to delete, you are automatically logged out when the fabric ID changes. To avoid being logged out, make sure you are in the context of a different logical switch from the one you are deleting.

- Connect to the physical chassis and log in using an account with admin permissions.
- Remove all ports from the logical switch as described in [Adding and moving ports on a logical switch](#) on page 289.
- Enter the **lsCfg** command to delete the logical switch:

```
lscfg --delete fabricID
```

The *fabricID* parameter is the fabric ID of the logical switch to be deleted.

## Example of deleting the logical switch with FID 7

```
switch_4:FID4:admin> lscfg --delete 7
A Logical switch with FID 7 will be deleted.
Would you like to continue [y/n]?y
All active login sessions for FID 7 have been terminated.
Switch successfully deleted.
```

## Adding and moving ports on a logical switch

You add ports to a logical switch by moving the ports from one logical switch to another. To remove a port from a logical switch, you must move the port to a different logical switch. You cannot just remove it.

When you move a port from one logical switch to another, the port is automatically disabled.

If you are deploying ICLs in the base switch, all ports associated with those ICLs must be assigned to the base switch. If you are deploying ICLs to connect to default switches (that is, XISL use is not allowed), the ICL ports should be assigned (or left) in the default logical switch.

See [Supported platforms for Virtual Fabrics](#) on page 281 for port restrictions.

- Connect to the physical chassis and log in using an account with the chassis-role permission.
- Enter the **lsCfg** command to move ports from one logical switch to another.

```
lscfg --config fabricID -slot slot -port port
```

The ports are assigned to the logical switch specified by *fabricID* and are removed from the logical switch on which they are currently configured.

If the **-port** option is omitted, all ports on the specified slot are assigned to the logical switch.

- Enter **y** at the prompt.

The ports are automatically disabled, then removed from their current logical switch, and assigned to the logical switch specified by *fabricID*.

## Example of assigning ports 18 through 20 to the logical switch with FID 5

### NOTE

On the Brocade DCX 8510-8, the `lscfg` command does not allow you to add ports 48-63 of the FC16-64 blade to the base switch. These ports are not supported on the base switch. The Brocade DCX 8510-4 does not have this limitation.

```
sw0:FID128:admin> lscfg --config 5 -port 18-20
This operation requires that the affected ports be disabled.
Would you like to continue [y/n]?: y
Making this configuration change. Please wait...
Configuration change successful.
Please enable your ports/switch when you are ready to continue.
```

## Displaying logical switch configuration

Use the following procedure to display the configuration for a logical switch:

1. Connect to the physical chassis and log in using an account with the chassis-role permission.
2. Enter the `lsCfg --show -n` command to display information about all of the logical switches.
3. Enter the `lsCfg --show` command to display a list of all logical switches and the ports assigned to them.

## Example of displaying basic information about all of the logical switches

```
sw0:FID128:admin> lscfg --show -n
-----
Switch Information
-----
FID: 5
SwitchType: BS
DomainID: 3
SwitchName: Base1
FabricName: Fab1
-----
FID: 128
SwitchType: DS
DomainID: 1
SwitchName: sw0
FabricName: DefFab
-----
```

## Example of displaying a list of all of the logical switches and the ports assigned to them

```
sw0:FID128:admin> lscfg --show
Created switches: 128(ds) 4 5
Port      0      1      2      3      4      5      6      7      8      9
-----
FID      128 | 128 | 128 | 128 | 128 | 128 | 128 | 128 | 5 | 5 |
(output truncated)
```

## Changing the fabric ID of a logical switch

The fabric ID indicates in which fabric the logical switch participates. By changing the fabric ID, you are moving the logical switch from one fabric to another.

Changing the fabric ID (FID) requires permission for chassis management operations. You cannot change the FID of your own logical switch context.

**NOTE**

If you are in the context of the logical switch with the fabric ID you want to change, you are automatically logged out when the fabric ID changes. To avoid being logged out, make sure you are in the context of a different logical switch from the one with the fabric ID you are changing.

1. Connect to the switch and log in using an account with admin permissions.
2. Enter the **lsCfg** command to change the fabric ID of a logical switch:

```
lscfg --change fabricID -newfid newFID
```

3. Enter **y** at the prompt.
4. Enable the logical switch.

```
fosexec --fid newFID -cmd "switchenable"
```

## Example of changing the fabric ID on the logical switch from 5 to 7

```
sw0:FID128:admin> lscfg --change 5 -newfid 7
Changing of a switch fid requires that the switch be disabled.
Would you like to continue [y/n]?: y
Disabling switch...
All active login sessions for FID 5 have been terminated.
Checking and logging message: fid = 5.
Please enable your switch.
sw0:FID128:admin> fosexec --fid 7 -cmd "switchenable"
-----
"switchenable" on FID 7:
```

## Changing a logical switch to a base switch

Use the following procedure to change a logical switch to a base switch.

1. Connect to the switch and log in using an account with the chassis-role permission.
2. Set the context to the logical switch you want to change, if you are not already in that context.

```
setcontext fabricID (or switchname)
```

The *fabricID* parameter is the FID of the logical switch you want to change to a base switch. The *switchname* parameter is the name assigned to the logical switch. You can only use one parameter at a time.

3. Configure the switch to *not* allow XISL use, as described in [Configuring a logical switch for XISL use](#) on page 292.
4. Enter the **lsCfg** command to change the logical switch to a base switch:

```
lscfg --change fabricID -base
```

The *fabricID* parameter is the fabric ID of the logical switch with the attributes you want to change.

5. Enable the switch.

```
switchenable
```

## Example of changing the logical switch with FID 7 to a base switch

```

sw0:FID128:admin> setcontext 7
switch_25:FID7:admin> switchshow
switchName:      switch_25
switchType:      66.1
switchState:     Online
switchMode:      Native
switchRole:      Principal
switchDomain:    30
switchId:        fffc1e
switchWwn:       10:00:00:05:1e:82:3c:2c
zoning:          OFF
switchBeacon:    OFF
FC Router:       OFF
Fabric Name:     MktFab7
HIF Mode:        ON
Allow XISL Use:  ON

LS Attributes:   [FID: 7, Base Switch: No, Default Switch: No, Address Mode 0]
(output truncated)
switch_25:FID7:admin> configure
Not all options will be available on an enabled switch.
To disable the switch, use the "switchDisable" command.
Configure...
Fabric parameters (yes, y, no, n): [no] y
  WWN Based persistent PID (yes, y, no, n): [no]
  Allow XISL Use (yes, y, no, n): [yes] n
  WARNING!! Disabling this parameter will cause removal of LISLs to
  other logical switches. Do you want to continue? (yes, y, no, n): [no] y
System services (yes, y, no, n): [no]
switch_25:FID7:admin> lscfg --change 7 -base
Creation of a base switch requires that the proposed new base switch on this system be disabled.
Would you like to continue [y/n]?: y
Disabling the proposed new base switch...
Disabling switch fid 7
Please enable your switches when ready.
switch_25:FID7:admin> switchenable

```

## Configuring a logical switch for XISL use

When you create a logical switch, it is configured to use XISLs by default. However, in some cases XISL use is not supported.

Use the following procedure to allow or disallow the logical switch to use XISLs in the base fabric.

See [Limitations and restrictions of Virtual Fabrics](#) on page 283 for restrictions on XISL use.

1. Connect to the physical chassis and log in using an account with the chassis-role permission.
2. Use the **setContext** command to set the context to the logical switch you want to manage, if you are not already in that context.

```
setcontext fabricID | switchname
```

The *fabricID* parameter is the FID of the logical switch you want to switch to and manage. The *switchname* parameter is the name assigned to the logical switch. You can only use one parameter at a time.

3. Use the **switchShow** command and check the value of the Allow XISL Use parameter.
4. Enter the **configure** command:

```
configure
```

5. Enter **y** after the Fabric Parameters prompt:

```
Fabric parameters (yes, y, no, n): [no] y
```



6. Enter **y** at the Allow XISL Use prompt to allow XISL use; enter **n** at the prompt to disallow XISL use:

```
Allow XISL Use (yes, y, no, n): y
```

7. Respond to the remaining prompts or press **Ctrl-d** to accept the other settings and exit.

## Changing the context to a different logical fabric

You can change the context to a different logical fabric. Your user account must have permission to access the logical fabric.

1. Connect to the physical chassis and log in using an account with the chassis-role permission.
2. Use the **setContext** command to switch to a different logical switch in the chassis:

```
setcontext fabricID | switchname
```

The *fabricID* parameter is the fabric ID of the logical switch you want to switch to and manage. The *switchname* parameter is the name assigned to the logical switch. You can only use one parameter at a time.

## Example of changing the context from FID 128 to FID 4

In this example, notice that the prompt changes when you change to a different logical fabric.

```
sw0:FID128:admin> setcontext 4
switch_4:FID4:admin>
```

## Creating a logical fabric using XISLs

This procedure describes how to create a logical fabric using multiple chassis and XISLs and refers to the configuration shown in [Figure 28](#) as an example.

FIGURE 28 Example of logical fabrics in multiple chassis and XISLs

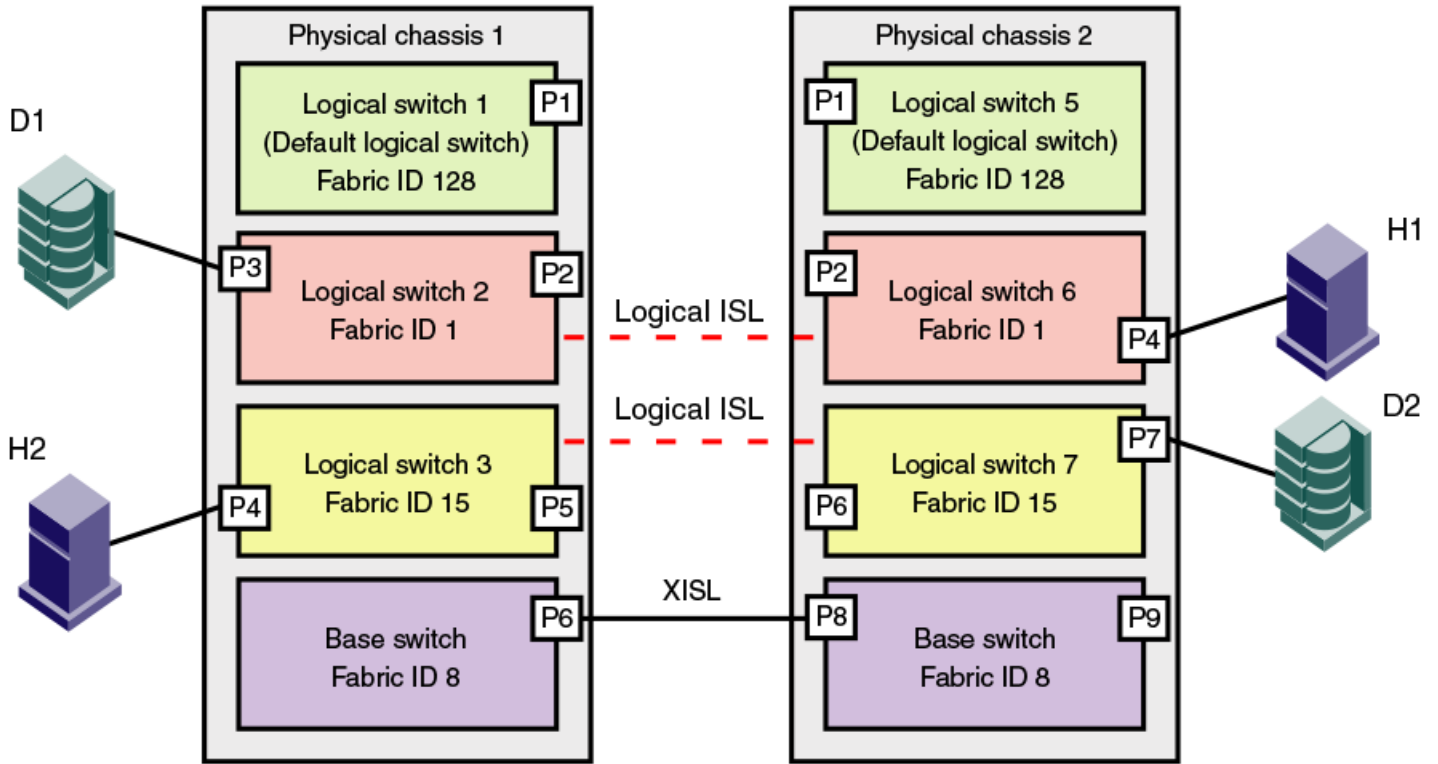

Use the following procedure to create a logical fabric using XISLs:

1. Set up the base switches in each chassis:
  - a) Connect to the physical chassis and log in using an account with the chassis-role permission.
  - b) Enable the Virtual Fabrics feature, if it is not already enabled. See [Enabling Virtual Fabrics mode](#) on page 284 for instructions.  
 Enabling Virtual Fabrics automatically creates the default logical switch, with FID 128. All ports in the chassis are assigned to the default logical switch.
  - c) Create a base switch and assign it a fabric ID that will become the FID of the base fabric. See [Creating a logical switch or base switch](#) on page 286 for instructions on creating a base switch.  
 For the example shown in [Figure 28](#), you would create a base switch with fabric ID 8.
  - d) Assign ports to the base switch, as described in [Adding and moving ports on a logical switch](#) on page 289.
  - e) Repeat step a through step d in all chassis that are to participate in the logical fabric.
2. Physically connect ports in the base switches to form XISLs.
3. Enable all of the base switches. This forms the base fabric.
4. Configure the logical switches in each chassis:
  - a) Connect to the physical chassis and log in using an account with the chassis-role permission.
  - b) Create a logical switch and assign it a fabric ID for the logical fabric. This FID must be different from the FID in the base fabric. See [Creating a logical switch or base switch](#) on page 286 for instructions.

For the example shown in [Figure 28](#), you would create a logical switch with FID 1 and a logical switch with FID 15.

- c) Assign ports to the logical switch, as described in [Adding and moving ports on a logical switch](#) on page 289.
- d) Physically connect devices and ISLs to these ports on the logical switch.
- e) (*Optional*) Configure the logical switch to use XISLs, if it is not already XISL-capable. See [Configuring a logical switch for XISL use](#) on page 292 for instructions.

By default, newly created logical switches are configured to allow XISL use.

- f) Repeat step a through step e in all chassis that are to participate in the logical fabric, using the same fabric ID whenever two switches need to be part of a single logical fabric.
5. Enable all logical switches by entering the **switchEnable** command on each logical switch that you created in step 4 (the base switches are already enabled).

The logical fabric is formed.

You can use the **fabricShow** command to display all logical switches configured with the same fabric ID as the local switch and all non-Virtual Fabrics switches connected through ISLs to these logical switches.

You can use the **switchShow** command to display logical ports as E\_Ports, with -1 for the slot and the user port number for the slot port.



# Administering Advanced Zoning

---

• Zone types.....	297
• Zoning overview.....	298
• Broadcast zones.....	303
• Zone aliases.....	304
• Zone creation and maintenance.....	307
• Default zoning mode.....	318
• Zone database size.....	320
• Zone configurations.....	320
• Zone object maintenance.....	329
• Zone configuration management.....	331
• Security and zoning.....	331
• Zone merging.....	332
• Concurrent zone transactions.....	339
• Peer Zoning.....	340
• Target Driven Zoning.....	347
• Supported commands for Peer Zones and Target Driven Peer Zones.....	351
• Boot LUN zoning.....	352

## Zone types

Zones enable you to partition your fabric into logical groups of devices that can access each other. These are "regular" or "standard" zones. Unless otherwise specified, all references to zones in this chapter refer to these regular zones. Beyond this, Fabric OS has the following types of special zones:

- Broadcast zones  
Control which devices receive broadcast frames. A broadcast zone restricts broadcast packets to members of the broadcast zone only. Refer to [Broadcast zones](#) on page 303 for more information.
- Frame redirection zones  
Re-route frames between an initiator and a target through a Virtual Initiator and Virtual Target for special processing or functionality, such as for storage virtualization or encryption. Refer to [Frame Redirection](#) on page 123 for more information.
- LSAN zones  
Provide device connectivity between fabrics without merging the fabrics. Refer to [LSAN zone configuration](#) on page 519 for more information. LSAN zones support RFIDs.
- QoS zones  
Assign high or low priority to designated traffic flows. These are regular zones with additional QoS attributes specified by adding a QoS prefix to the zone name. Refer to [QoS](#) on page 388 for more information.
- Traffic Isolation zones (TI zones)  
Isolate traffic to a specific, dedicated path through the fabric. Refer to [Traffic Isolation Zoning](#) on page 357 for more information.
- Peer zones  
Allow a principal device port to communicate with other members of the zone. Refer to [Peer Zoning](#) on page 340 for more information.
- Target driven zones

Allow targets to create or activate peer zones. Refer to [Target Driven Zoning](#) on page 347 for more information.

## Zoning overview

Zoning is a fabric-based service that enables you to partition your storage area network (SAN) into logical groups of devices that can access each other.

For example, you can partition your SAN into two zones, "winzone" and "unixzone", so that your Windows servers and storage do not interact with your UNIX servers and storage. You can use zones to logically consolidate equipment for efficiency or to facilitate time-sensitive functions; for example, you can create a temporary zone to back up nonmember devices.

A device in a zone can communicate only with other devices connected to the fabric within the same zone. A device not included in the zone is not available to members of that zone. When zoning is enabled, devices that are not included in *any* zone configuration are inaccessible to all other devices in the fabric.

Zones can be configured dynamically. They can vary in size, depending on the number of fabric-connected devices, and devices can belong to more than one zone.

Consider [Figure 29](#), which shows a FC fabric with three configured zones: Red, Green, and Blue. Within this fabric, the following is true:

- Server 1 can communicate only with the Loop 1 storage devices. (Red zone)
- Server 2 can communicate only with the RAID storage devices. (Blue zone)
- Server 3 can communicate with the RAID and Loop 1 storage devices. (Green zone)
- Loop 2 is not assigned to a zone; no other zoned fabric device can access it.

FIGURE 29 Zoning example

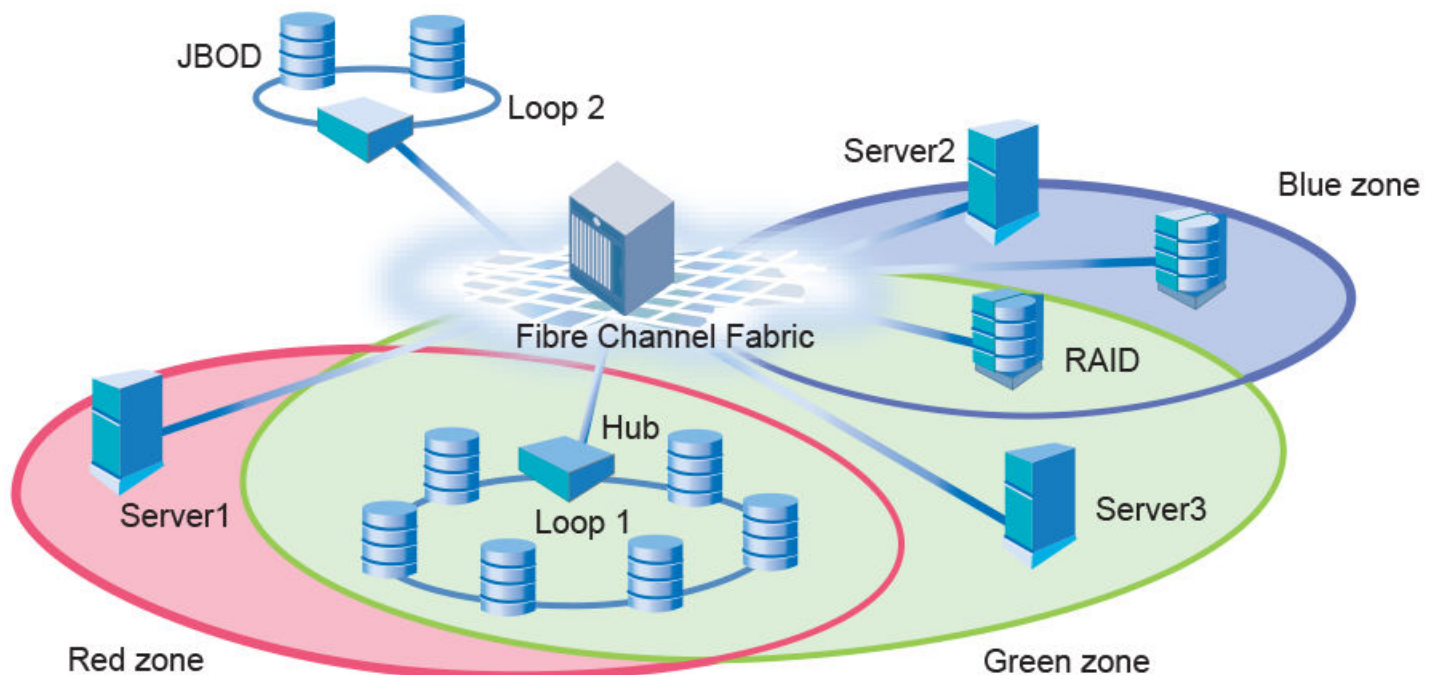

Refer to [Best practices for zoning](#) on page 302 for additional information that should be kept in mind when working with zones.

To list the commands associated with zoning, use the `zoneHelp` command. For detailed information on the zoning commands used in the procedures, refer to the *Fabric OS Command Reference*.

## Approaches to zoning

Table 62 lists the various approaches you can take when implementing zoning in a fabric.

**TABLE 62** Approaches to fabric-based zoning

Zoning approach	Description
Recommended approach	
Single HBA	<p>Zoning by single HBA most closely re-creates the original SCSI bus. Each zone created has only one HBA (initiator) in the zone; each of the target devices is added to the zone. Typically, a zone is created for the HBA and the disk storage ports are added. If the HBA also accesses tape devices, a second zone is created with the HBA and associated tape devices in it. In the case of clustered systems, it could be appropriate to have an HBA from each of the cluster members included in the zone; this is equivalent to having a shared SCSI bus between the cluster members and assumes that the clustering software can manage access to the shared devices.</p> <p>In a large fabric, zoning by single HBA requires the creation of possibly hundreds of zones; however, each zone contains only a few members. Zone changes affect the smallest possible number of devices, minimizing the impact of an incorrect zone change. This zoning philosophy is the preferred method.</p>
Alternative approaches	
Application	<p>Zoning by application typically requires zoning multiple, perhaps incompatible, operating systems into the same zones. This method of zoning creates the possibility that a minor server in the application suite could disrupt a major server (such as a Web server disrupting a data warehouse server). Zoning by application can also result in a zone with a large number of members, meaning that more notifications, such as registered state change notifications (RSCNs), or errors, go out to a larger group than necessary.</p>
Operating system	<p>Zoning by operating system has issues similar to zoning by application. In a large site, this type of zone can become very large and complex. When zone changes are made, they typically involve applications rather than a particular server type. If members of different operating system clusters can see storage assigned to another cluster, they might attempt to own the other cluster's storage and compromise the stability of the clusters.</p>
Port allocation	<p>Avoid zoning by port allocation unless the administration team has very rigidly enforced processes for port and device allocation in the fabric. Zoning by port allocation does, however, provide some positive features. For instance, when a storage port, server HBA, or tape drive is replaced, the change of WWN for the new device is of no consequence. As long as the new device is connected to the original port, it continues to have the same access rights. The ports on the edge switches can be pre-associated to storage ports, and control of the fan-in ratio (the ratio of the input port to output port) can be established. With this pre-assigning technique, the administrative team cannot overload any one storage port by associating too many servers with it.</p>
Not recommended	
No fabric zoning	<p>Using no fabric zoning is the least desirable zoning option because it allows devices to have unrestricted access on the fabric. Additionally, any device attached to the fabric, intentionally or maliciously, likewise has</p>

**TABLE 62** Approaches to fabric-based zoning (continued)

Zoning approach	Description
	unrestricted access to the fabric. This form of zoning should be utilized only in a small and tightly controlled environment, such as when host-based zoning or LUN masking is deployed.

## Zone objects

A *zone object* is any device in a zone, such as:

- Physical port number or port index on the switch
- Node World Wide Name (N-WWN)
- Port World Wide Name (P-WWN)

Zone objects identified by port number or index number are specified as a pair of decimal numbers in the form *D,I*, where *D* is the domain ID of the switch and *I* is the index number on that switch in relation to the port you want to specify.

For example, in Backbones, "4,30" specifies port 14 in slot number 2 (domain ID 4, port index 30). On fixed-port models, "3,13" specifies port 13 in switch domain ID 3.

The following issues affect zone membership based on the type of zone object:

- When a zone object is the physical port number, then all devices connected to that port are in the zone.
- World Wide Names are specified as 8-byte (16-digit) hexadecimal numbers, separated by colons (:), for example, 10:00:00:90:69:00:00:8a.
- When a zone object is the node WWN name, only the specified device is in the zone.
- When a zone object is the port WWN name, only the single port is in the zone.

### NOTE

Using a WWN in the same format as a peer property member (starting with "00") is not allowed.

The types of zone objects used to define a zone can be mixed. For example, a zone defined with the zone objects 2,12; 2,14; 10:00:00:80:33:3f:aa:11 contains the devices connected to domain 2, ports 12 and 14, and a device with the WWN 10:00:00:80:33:3f:aa:11 (either node name or port name) that is connected on the fabric.

## Zoning schemes

You can establish a zone by identifying zone objects using one or more of the following *zoning schemes*:

- Domain,index (D,I)  
All members are specified by *domain ID*, *port number*, or *domain,index number* pairs or aliases.
- World Wide Name (WWN)  
All members are specified only by World Wide Names (WWNs) or aliases of WWNs. They can be node or port versions of the WWN.
- Mixed zoning  
A zone containing members specified by a combination of *domain,port* or *domain,index* or aliases, and WWNs or aliases of WWNs.

In any scheme, you can identify zone objects using aliases.



## Zone configurations

A *zone configuration* is a group of one or more zones. A zone can be included in more than one zone configuration. When a zone configuration is in effect, all zones that are members of that configuration are in effect.

Several zone configurations can reside on a switch at once, and you can quickly alternate between them. For example, you might want to have one configuration enabled during the business hours and another enabled overnight. However, only one zone configuration can be enabled at a time.

The different types of zone configurations are:

- **Defined configuration**  
The complete set of all zone objects defined in the fabric.
- **Effective configuration**  
A single zone configuration that is currently in effect. The effective configuration is built when you enable a specified zone configuration.
- **Saved configuration**  
A copy of the defined configuration plus the name of the effective configuration, which is saved in flash memory. (You can also provide a backup of the zone configuration and restore the zone configuration.) There might be differences between the saved configuration and the defined configuration if you have modified any of the zone definitions and have not saved the configuration.
- **Disabled configuration**  
The effective configuration is removed from flash memory.

If you disable the effective configuration, the Advanced Zoning feature is disabled on the fabric, and all devices within the fabric can communicate with all other devices (unless you previously set up a default zone, as described in [Default zoning mode](#) on page 318). This does not mean that the zone database is deleted, however, only that there is no configuration active in the fabric.

On power-up, the switch automatically reloads the saved configuration. If a configuration was active when it was saved, the same configuration is reinstated on the local switch.

## Zoning enforcement

Zoning enforcement describes a set of predefined rules that the switch uses to determine where to send incoming data. Fabric OS uses hardware-enforced zoning. *Hardware-enforced zoning* means that each frame is checked by hardware (the ASIC) before it is delivered to a zone member and is discarded if there is a zone mismatch. When hardware-enforced zoning is active, the Fabric OS switch monitors the communications and blocks any frames that do not comply with the effective zone configuration. The switch performs this blocking at the transmit side of the port on which the destination device is located.

There are two methods of hardware enforcement:

- **Frame-based hardware enforcement:** All frames are checked by the hardware.
- **Session-based hardware enforcement:** The only frames checked by hardware are the ELS frames (such as PLOGI and RNID) used to establish a session.

The hardware-enforcement method used depends on how the zones are configured.

A zone can contain all WWN members, or all D,I members, or a combination of WWN and D,I members.

Frame-based hardware enforcement is in effect if all members of a zone are identified the same way, either using WWNs or D,I notation, but not both. If the zone includes aliases, then the aliases must also be defined the same way as the zone.

Session-based hardware enforcement is in effect if the zone has a mix of WWN and D,I members.

If a port is in multiple zones, and is defined by WWN in one zone and by D.I in another, then session-based hardware enforcement is in effect.

## Identifying the enforced zone type

Use the following procedure to identify zones and zone types:

1. Connect to the switch and log in using an account with admin permissions.
2. Enter the `portZoneShow` command.

## Considerations for zoning architecture

Table 63 lists considerations for zoning architecture.

**TABLE 63** Considerations for zoning architecture

Item	Description
Type of zoning enforcement: frame- or session-based	If security is a priority, frame-based hardware enforcement is recommended. The best way to do this is to use WWN identification exclusively for all zoning configurations.
Use of aliases	The use of aliases is optional with zoning. Using aliases requires structure when defining zones. Aliases aid administrators of zoned fabrics in understanding the structure and context.
Effect of changes in a production fabric	Zone changes in a production fabric can result in a disruption of I/O under conditions when an RSCN is issued because of the zone change and the HBA is unable to process the RSCN fast enough. Although RSCNs are a normal part of a functioning SAN, the pause in I/O might not be acceptable. For these reasons, you should perform zone changes only when the resulting behavior is predictable and acceptable. Ensuring that the HBA drivers are current can shorten the response time in relation to the RSCN.
Testing	Before implementing a new zone, you should run the Zone Analyzer from Web Tools to isolate any possible problems. This is especially useful as fabrics increase in size.
Confirming operation	After changing or enabling a zone configuration, you should confirm that the nodes and storage can identify and access one another. Depending on the platform, you might need to reboot one or more nodes in the fabric with the new changes.

Zoning can be implemented and administered from any switch in the fabric, although it is recommended that you use a switch running the latest Fabric OS version.

The zone configuration is managed on a fabric basis. When a change in the configuration is saved, enabled, or disabled according to the transactional model, it is automatically (by closing the transaction) distributed to all switches in the fabric, preventing a single point of failure for zone information.

### NOTE

Zoning commands make changes that affect the entire fabric. When executing fabric-level configuration tasks, allow time for the changes to propagate across the fabric before executing any subsequent commands. For a large fabric, you should wait several minutes between commands.

## Best practices for zoning

The following are recommendations for using zoning:

- When using a mixed fabric — that is, a fabric containing two or more switches running different release levels of Fabric OS — you should use the switch with the latest Fabric OS level to perform zoning tasks.

Switches with earlier versions of Fabric OS do not have the same capability to view all the functionality that more recent versions of Fabric OS provide, as functionality is backwards-compatible but not forward-compatible.

- Zone using the core switch in preference to using an edge switch.
- Zone using a Backbone rather than a switch. A Backbone has more resources to handle zoning changes and implementations.
- When you are adding a switch to an existing fabric, prior to joining the fabric you must set the defzone policy of the switch being added as follows:
  - If the joining switch has locally-attached devices that are online, the defzone policy of the switch being added should be set to "No Access".
  - If the joining switch has no online locally-attached devices the defzone policy of the switch being added can be set to "All Access".

This is done to avoid a transitional state where the "All Access" policy might lead to excessive RSCN activity; with extreme cases having the potential for additional adverse effects. This is especially important for fabrics having a very high device count.

- Initial WWNs starting with 'OO' are for engineering use only and are auto-created. Starting with Fabric OS 7.3.0, zones having initial WWNs starting with 'OO' are treated as peer zones. This means that when you attempt one of the following,
  - A firmware upgrade from firmware earlier than Fabric OS 7.3.0
  - A merge with a switch running firmware earlier than Fabric OS 7.3.0
  - A configuration download using firmware earlier than Fabric OS 7.3.0

and the WWN of the first zone member starts with 'OO', Fabric OS will treat the zone as a peer zone. You must delete such invalid zones before continuing. Refer to [Deleting invalid zones](#) on page 325 for instructions on doing so.

## Broadcast zones

Fibre Channel allows sending broadcast frames to all Nx\_Ports if the frame is sent to a broadcast well-known address (FFFFFF); however, many target devices and HBAs cannot handle broadcast frames. To control which devices receive broadcast frames, you can create a special zone, called a *broadcast zone*, that restricts broadcast packets to only those devices that are members of the broadcast zone.

If there are no broadcast zones or if a broadcast zone is defined but not enabled, broadcast frames are not forwarded to any F\_Ports. If a broadcast zone is enabled, broadcast frames are delivered only to those logged-in Nx\_Ports that are members of the broadcast zone and are also in the same zone (regular zone) as the sender of the broadcast packet.

Devices that are not members of the broadcast zone can send broadcast packets, even though they cannot receive them.

A broadcast zone can have *domain,port*, WWN, and alias members.

Broadcast zones do not function in the same way as other zones. A broadcast zone does not allow access within its members in any way. If you want to allow or restrict access between any devices, you must create regular zones for that purpose. If two devices are not part of a regular zone, they cannot exchange broadcast or unicast packets.

To restrict broadcast frames reaching broadcast-incapable devices, create a broadcast zone and populate it with the devices that are capable of handling broadcast packets. Devices that cannot handle broadcast frames must be kept out of the broadcast zone so that they do not receive any broadcast frames.

You create a broadcast zone the same way you create any other zone except that a broadcast zone must have the name "broadcast" (case-sensitive). To enable the broadcast zoning, use **cfgenable** command to add the broadcast zones to the active zone configuration. You set up and manage broadcast zones using the standard zoning commands, described in [Zone creation and maintenance](#) on page 307.

## Broadcast zones and FC-FC routing

If you create broadcast zones in a metaSAN consisting of multiple fabrics connected through an FC router, the broadcast zone must include the IP device that exists in the edge or backbone fabric as well as the proxy device in the remote fabric. Refer to [Using FC-FC Routing to Connect Fabrics](#) on page 489 for information about proxy devices and the FC router.

## High availability considerations with broadcast zones

If a switch has broadcast zone-capable firmware on the active CP (Fabric OS v5.3.x or later) and broadcast zone-incapable firmware on the standby CP (Fabric OS version earlier than v5.3.0), then you cannot create a broadcast zone because the zoning behavior would not be the same across an HA failover. If the switch failed over, then the broadcast zone would lose its special significance and would be treated as a regular zone.

## Loop devices and broadcast zones

Delivery of broadcast packets to individual devices in a loop is not controlled by the switch. Consequently, adding loop devices to a broadcast zone does not have any effect. If a loop device is part of a broadcast zone, then all devices in that loop receive broadcast packets.

**Best practice:** All devices in a single loop should have uniform broadcast capability. If all the devices in the loop can handle broadcast frames, then add the FL\_Port to the broadcast zone.

## Broadcast zones and default zoning mode

The default zoning mode defines the device accessibility behavior if zoning is not implemented or if there is no effective zone configuration. The default zoning mode has two options:

- All Access--All devices within the fabric can communicate with all other devices.
- No Access--Devices in the fabric cannot access any other device in the fabric.

If a broadcast zone is active, even if it is the only zone in the effective configuration, the default zone setting is not in effect.

If the effective configuration has only a broadcast zone, then the configuration appears as a No Access configuration. To change this configuration to All Access, you must put all the available devices in a regular zone.

Refer to [Default zoning mode](#) on page 318 for additional information about default zoning.

## Zone aliases

A *zone alias* is a name assigned to a logical group of ports or WWNs. By creating an alias, you can assign a familiar name to a device or group multiple devices into a single name. This simplifies cumbersome data entry and allows an intuitive naming structure (such as using "NT\_Hosts" to define all NT hosts in the fabric). Using zone aliases eliminates the need for long lists of individual zone member names.

Zone aliases also simplify repetitive entry of zone objects such as port numbers or a WWN. For example, you can use the name "Eng" as an alias for "10:00:00:80:33:3f:aa:11".

Naming zones for the initiator they contain can also be useful. For example, if you use the alias SRV\_MAILSERVER\_SLT5 to designate a mail server in PCI slot 5, then the alias for the associated zone is ZNE\_MAILSERVER\_SLT5. This clearly identifies the server host bus adapter (HBA) associated with the zone.

Zone configuration naming is flexible. One configuration should be named PROD\_*fabricname*, where *fabricname* is the name that the fabric has been assigned. The purpose of the PROD configuration is to easily identify the configuration that can be implemented and provide the most generic services. If other configurations are used for specialized purposes, names such as "BACKUP\_A,"

"RECOVERY\_2," and "TEST\_18jun02" can be used. If you are creating a new alias using **aliCreate w, "1,1"**, and a user in another Telnet session executes **cfgEnable** (or **cfgDisable**, or **cfgSave**), the other user's transaction will abort your transaction and you will receive an error message. Creating a new alias while there is a zone merge taking place may also abort your transaction. For more details about zone merging and zone merge conflicts, refer to [Zone merging](#) on page 332.

**Virtual Fabrics considerations:** Alias definitions should not include logical port numbers. Zoning is not enforced on logical ports.

## Creating an alias

Use the following procedure to create an alias.

1. Connect to the switch and log in using an account with admin permissions.
2. Enter the **aliCreate** command, using the following syntax:

```
alicreate "aliasname", "member[; member...]"
```

3. Enter the **cfgSave** command to save the change to the defined configuration.

The **cfgSave** command ends and commits the current zoning transaction buffer to nonvolatile memory. If a transaction is open on a different switch in the fabric when this command is run, the transaction on the other switch is automatically aborted. A message displays on the other switches to indicate that the transaction was aborted.

Example

```
switch:admin> alicreate "array1", "2,32; 2,33; 2,34; 4,4"
switch:admin> alicreate "array2", "21:00:00:20:37:0c:66:23; 4,3"
switch:admin> alicreate "loop1", "4,6"
switch:admin> cfgsave

WARNING!!!
You are about to save the Defined zoning configuration. This
action will only save the changes on Defined configuration.
If the update includes changes to one or more traffic isolation
zones, you must issue the 'cfgenable' command for the changes
to take effect.
Do you want to save the Defined zoning configuration only? (yes, y, no, n): [no]
```

## Adding members to an alias

Use the following procedure to add a member to an alias.

1. Connect to the switch and log in using an account with admin permissions.
2. Enter the **aliAdd** command, using the following syntax:

```
aliadd "aliasname ", "member[; member...]"
```

3. Enter the **cfgSave** command to save the change to the defined configuration.

The **cfgSave** command ends and commits the current zoning transaction buffer to nonvolatile memory. If a transaction is open on a different switch in the fabric when this command is run, the transaction on the other switch is automatically aborted. A message displays on the other switches to indicate that the transaction was aborted.

Example

```
switch:admin> aliadd "array1", "1,2"
switch:admin> aliadd "array2", "21:00:00:20:37:0c:72:51"
```

```
switch:admin> aliadd "loop1", "5,6"
switch:admin> cfgsave

WARNING!!!
You are about to save the Defined zoning configuration. This
action will only save the changes on Defined configuration.
If the update includes changes to one or more traffic isolation
zones, you must issue the 'cfgenable' command for the changes
to take effect.
Do you want to save the Defined zoning configuration only? (yes, y, no, n): [no]
```

## Removing members from an alias

Use the following procedure to remove a member from an alias.

1. Connect to the switch and log in using an account with admin permissions.
2. Enter the **aliRemove** command, using the following syntax:

```
aliremove "aliasname ", "member [; member...]"
```

3. Enter the **cfgSave** command to save the change to the defined configuration.

The **cfgSave** command ends and commits the current zoning transaction buffer to nonvolatile memory. If a transaction is open on a different switch in the fabric when this command is run, the transaction on the other switch is automatically aborted. A message displays on the other switches to indicate that the transaction was aborted.

Example

```
switch:admin> aliremove "array1", "1,2"

switch:admin> aliremove "array2", "21:00:00:20:37:0c:72:51"

switch:admin> aliremove "loop1", "4,6"
switch:admin> cfgsave

WARNING!!!
You are about to save the Defined zoning configuration. This
action will only save the changes on Defined configuration.
If the update includes changes to one or more traffic isolation
zones, you must issue the 'cfgenable' command for the changes
to take effect.
Do you want to save the Defined zoning configuration only? (yes, y, no, n): [no]
```

## Deleting an alias

Use the following procedure to delete an alias.

1. Connect to the switch and log in using an account with admin permissions.
2. Enter the **aliDelete** command, using the following syntax.

```
alidelete "aliasname"
```

3. Enter the **cfgSave** command to save the change to the defined configuration.

The **cfgSave** command ends and commits the current zoning transaction buffer to nonvolatile memory. If a transaction is open on a different switch in the fabric when this command is run, the transaction on the other switch is automatically aborted. A message displays on the other switches to indicate that the transaction was aborted.

### Example

```
switch:admin> alidelete "array1"

switch:admin> cfgsave
WARNING!!!
You are about to save the Defined zoning configuration. This
action will only save the changes on Defined configuration.
If the update includes changes to one or more traffic isolation
zones, you must issue the 'cfgenable' command for the changes
to take effect.
Do you want to save the Defined zoning configuration only? (yes, y, no, n): [no]
```

## Viewing an alias in the defined configuration

To view an alias in the defined configuration, complete the following steps.

1. Connect to the switch and log in using an account with admin permissions.
2. Enter the **aliShow** command, followed optionally by the **--ic**, *"pattern"*, and *mode* operands to display the zone configuration information.

### NOTE

If you do not specify any parameters, the entire zone database (both the defined and effective configuration) is displayed. Refer to the *Fabric OS Command Reference* for more information on this command.

## Displaying all zone aliases regardless of case

The following example shows all zone aliases beginning with "arr", regardless of the case:

```
switch:admin> alishow --ic "arr*"
alias: array1 20:e0:00:05:33:11:1f:00
alias: ARRAY2 50:11:00:05:33:c1:37:a2
alias: array3 21:00:00:20:37:0c:66:23
```

## Displaying all zone aliases

The following example shows all zone aliases beginning with "arr", but not if the alias uses these characters in a different case. Here "array1" and "array3" are displayed, but not "ARRAY2":

```
switch:admin> alishow "arr*"
alias: array1 21:00:00:20:37:0c:76:8c
alias: array3 21:00:00:20:37:0c:66:23
```

## Zone creation and maintenance

Fabric OS allows you to create zones to better manage devices.

The following items should be taken into account when creating zones:

- Broadcast zone — To create a broadcast zone, use the reserved name "broadcast". Do *not* give a regular zone this name. Refer to [Broadcast zones](#) on page 303 for additional information about this special type of zone.
- Virtual Fabrics — Zone definitions should not include logical port numbers. Zoning is not enforced on logical ports.

## Displaying existing zones

Use the following procedure to display a list of existing zones.

1. Connect to the switch and log in using an account with admin permissions.
2. Enter the **cfgShow** command.

Example of displaying existing zones

```
switch:admin> cfgshow

Defined configuration:
zone: matt 30:06:00:07:1e:a2:10:20; 3,2
alias: bawn 3,5; 4,8
alias: bolt 10:00:00:02:1f:02:00:01
alias: bond 10:00:05:1e:a9:20:00:01; 3,5
alias: brain 11,4; 22,1; 33,6
alias: jake 4,7; 8,9; 14,11
alias: jeff 30:00:00:05:1e:a1:cd:02; 40:00:00:05:1e:a1:cd:04
alias: jones 7,3; 4,5
alias: zeus 4,7; 6,8; 9,2
Effective configuration:
No Effective configuration: (No Access)
```

## Creating a zone

### ATTENTION

The **zoneCreate** command will add *all* zone member aliases that match the "*aliasname\_pattern*" in the zone database to the new zone.

Use the following procedure to create a zone.

1. Connect to the switch and log in using an account with admin permissions.
2. Enter the **zoneCreate** command, using either of the following syntaxes:

```
zonecreate "zonename ", "member[; member...]"
zonecreate "zonename ", "aliasname_pattern *[,members]"
```

### NOTE

The **zoneCreate** command supports partial pattern matching ("wildcards") of zone member aliases. This allows you to add multiple aliases that match the "*aliasname\_pattern*" in the command line.

To create a broadcast zone, use the reserved name "broadcast".

3. Enter the **cfgSave** command to save the change to the defined configuration.

The **cfgSave** command ends and commits the current zoning transaction buffer to nonvolatile memory. If a transaction is open on a different switch in the fabric when this command is run, the transaction on the other switch is automatically aborted. A message displays on the other switches to indicate that the transaction was aborted.

4. Enter the **cfgShow** command to view the changes.

Example of creating a new zone

```
switch:admin> zonecreate sloth, "b*"; 10:00:00:00:01:1e:20:20"

switch:admin> cfgsave

switch:admin> cfgenable

switch:admin> cfgshow

Defined configuration:
zone: matt 30:06:00:07:1e:a2:10:20; 3,2
zone: sloth bawn; bolt; bond; brain; 10:00:00:00:01:1e:20:20 alias: bawn 3,5; 4,8
alias: bolt 10:00:00:02:1f:02:00:01
```



```
alias: bond 10:00:05:1e:a9:20:00:01; 3,5
alias: brain 11,4; 22,1; 33,6
alias: jake 4,7; 8,9; 14,11
alias: jeff 30:00:00:05:1e:a1:cd:02; 40:00:00:05:1e:a1:cd:04
alias: jones 7,3; 4,5
alias: zeus 4,7; 6,8; 9,2
Effective configuration:
No Effective configuration: (No Access)
```

## Adding devices (members) to a zone

### ATTENTION

The **zoneAdd** command will add *all* zone member aliases that match the "*aliasname\_pattern*" in the zone database to the specified zone.

Use the following procedure to add members to a zone:

1. Connect to the switch and log in using an account with admin permissions.
2. Enter the **zoneAdd** command, using either of the following syntaxes:

```
zoneadd "zonename", "member [; member...]"
zoneadd "zonename ", "aliasname_pattern* [;members ]"
```

### NOTE

The **zoneAdd** command supports partial pattern matching ("wildcards") of zone member aliases. This allows you to add multiple aliases that match the "*aliasname\_pattern*" in the command line.

3. Enter the **cfgSave** command to save the change to the defined configuration.

The **cfgSave** command ends and commits the current zoning transaction buffer to nonvolatile memory. If a transaction is open on a different switch in the fabric when this command is run, the transaction on the other switch is automatically aborted. A message displays on the other switches to indicate that the transaction was aborted.

4. Enter the **cfgShow** command to view the changes.

Example for adding members to a zone

```
switch:admin> zoneadd matt, "ze*; bond*; j*"
switch:admin> cfgsave
switch:admin> cfgshow

Defined configuration:
zone: matt 30:06:00:07:1e:a2:10:20; 3,2; zeus; bond; jake; jeff; jones
zone: sloth bawn; bolt; bond; brain; 10:00:00:00:01:1e:20:20
alias: bawn 3,5; 4,8
alias: bolt 10:00:00:02:1f:02:00:01
alias: bond 10:00:05:1e:a9:20:00:01; 3,5
alias: brain 11,4; 22,1; 33,6
alias: jake 4,7; 8,9; 14,11
alias: jeff 30:00:00:05:1e:a1:cd:02; 40:00:00:05:1e:a1:cd:04
alias: jones 7,3; 4,5
alias: zeus 4,7; 6,8; 9,2
Effective configuration:
No Effective configuration: (No Access)
```

## Removing devices (members) from a zone

### ATTENTION

The **zoneRemove** command will remove *all* zone member aliases that match the "*aliasname\_pattern*" in the zone database from the specified zone.

Use the following procedure to remove members from a zone:

1. Connect to the switch and log in using an account with admin permissions.
2. Enter the **zoneRemove** command, using either of the following syntaxes:

```
zoneremove "zonename ", "member [; member ...]"

zoneremove "zonename ", "aliasname_pattern* [;members ]"
```

### NOTE

This command supports partial pattern matching ("wildcards") of zone member aliases. This allows you to remove multiple aliases that match the "*aliasname\_pattern*" in the command line.

3. Enter the **cfgSave** command to save the change to the defined configuration.

The **cfgSave** command ends and commits the current zoning transaction buffer to nonvolatile memory. If a transaction is open on a different switch in the fabric when this command is run, the transaction on the other switch is automatically aborted. A message displays on the other switches to indicate that the transaction was aborted.

4. Enter the **cfgShow** command to view the changes.

Examples removing members from a zone

```
switch:admin> cfgshow

Defined configuration:
zone: matt   zeus; bond; jake; jeff; jones; 3,2; 30:06:00:07:1e:a2:10:20
zone: sloth  bawn; bolt; bond; brain; 10:00:00:00:01:1e:20:20
alias:      bawn  3,5; 4,8
alias:      bolt  10:00:00:02:1f:02:00:01
alias:      bond  10:00:05:1e:a9:20:00:01; 3,5
alias:      brain 11,4; 22,1; 33,6
alias:      jake  4,7; 8,9; 14,11
alias:      jeff  30:00:00:05:1e:a1:cd:02; 40:00:00:05:1e:a1:cd:04
alias:      jones 7,3; 4,5
alias:      zeus  4,7; 6,8; 9,2
Effective configuration:
No Effective configuration: (No Access)
switch:admin>
switch:admin> zoneremove matt,"30:06:00:07:1e:a2:10:20; ja*; 3,2"

switch:admin> cfgsave

switch:admin> cfgshow

Defined configuration:
zone: matt   zeus; bond; jeff; jones zone: sloth  bawn; bolt; bond; brain; 10:00:00:00:01:1e:20:20
alias:      bawn  3,5; 4,8
alias:      bolt  10:00:00:02:1f:02:00:01
alias:      bond  10:00:05:1e:a9:20:00:01; 3,5
alias:      brain 11,4; 22,1; 33,6
alias:      jake  4,7; 8,9; 14,11
alias:      jeff  30:00:00:05:1e:a1:cd:02; 40:00:00:05:1e:a1:cd:04
alias:      jones 7,3; 4,5
alias:      zeus  4,7; 6,8; 9,2
Effective configuration:
No Effective configuration: (No Access)
```

## Replacing zone members

Fabric OS allows you to replace one zone member with another zone member using a CLI command. This command takes two inputs. The first is the member to be replaced and the second is the new member. These inputs can be formatted only with WWN or D.I zoning schemes.

### Notes and restrictions

- To make a configuration change effective, a **cfgEnable** command should be issued after the **zoneObjectReplace** command. Otherwise, the changes will be in the transaction buffer but not committed.
- Only members of regular zones and aliases (those identified using either *D,I* or WWN) can be replaced using **zoneObjectReplace**.
- The **zoneObjectReplace** command is not applicable for Frame Redirect (FR) and Traffic Isolation (TI) zones. Only members of regular zones can be replaced using this command.
- The **zoneObjectReplace** command does not work with aliases. Alias members (that is, members inside an alias) can be replaced using **zoneObjectReplace**, but an alias itself cannot be directly replaced. To achieve the effect of replacement, create a new alias (with the desired new name) containing the same members, and then delete the old alias.

Use the following procedure to replace members in a zone.

1. Connect to the switch and log in using an account with admin permissions.
2. Enter the **zoneObjectReplace** command, using the following syntax:

```
zoneobjectreplace old wwn/D,I new wwn/D,I
```

#### NOTE

The **zoneObjectReplace** command does *not* support partial pattern matching ("wildcards") of zone member aliases.

3. Enter the **cfgSave** command to save the change to the defined configuration.

The **cfgSave** command ends and commits the current zoning transaction buffer to nonvolatile memory. If a transaction is open on a different switch in the fabric when this command is run, the transaction on the other switch is automatically aborted. A message displays on the other switches to indicate that the transaction was aborted.

4. Enter the **cfgShow** command to view the changes.

Example replacing zone members

```
switch:admin> cfgshow

Defined configuration:
zone: matt  zeus; bond; jeff;jones; 11, 2
zone: sloth bawn; bolt; bond; brain; brit; bru; 10:00:00:00:01:1e:20:20
alias:      bawn  3,5
alias:      bolt  10:00:00:02:1f:02:00:01
alias:      bond  10:00:05:1e:a9:20:00:01; 3,5
alias:      brain 11,4; 22,1; 33,6
alias:      jake  4,7; 8,9; 14,11
alias:      jeff  30:00:00:05:1e:a1:cd:02; 40:00:00:05:1e:a1:cd:04
alias:      jones 7,3; 4,5
alias:      zeus  4,7; 6,8; 9,2
Effective configuration:
No Effective configuration: (No Access)
switch:admin>
switch:admin> zoneobjectreplace 11,2 4,8

switch:admin> cfgsave

switch:admin> cfgshow
```

```

Defined configuration:
zone: matt   zeus; bond; jeff; 4,8
zone: sloth  bawn; bolt; bond; brain; 10:00:00:00:01:1e:20:20
alias:      bawn   3,5
alias:      bolt   10:00:00:02:1f:02:00:01
alias:      bond   10:00:05:1e:a9:20:00:01; 3,5
alias:      brain  11,4; 22,1; 33,6
alias:      jake   4,7; 8,9; 14,11
alias:      jeff   30:00:00:05:1e:a1:cd:02; 40:00:00:05:1e:a1:cd:04
alias:      jones  7,3; 4,5
alias:      zeus   4,7; 6,8; 9,2
Effective configuration:
No Effective configuration: (No Access)

```

**CAUTION**

Executing this command replaces all instances of the older member with the new member in the entire zone database.

## Deleting a zone

Use the following procedure to delete a zone.

1. Connect to the switch and log in using an account with admin permissions.
2. Enter the **zoneDelete** command, using the following syntax:

```
zonedeldelete "zonename"
```

3. Enter the **cfgSave** command to save the change to the defined configuration.

The **cfgSave** command ends and commits the current zoning transaction buffer to nonvolatile memory. If a transaction is open on a different switch in the fabric when this command is run, the transaction on the other switch is automatically aborted. A message displays on the other switches to indicate that the transaction was aborted.

Example of deleting zone members

```

switch:admin> cfgshow

Defined configuration:
zone: matt   zeus; bond; jeff; 4,8
zone: sloth  bawn; bolt; bond; brain; brit; bru; 10:00:00:00:01:1e:20:20
alias:      bawn   3,5
alias:      bolt   10:00:00:02:1f:02:00:01
alias:      bond   10:00:05:1e:a9:20:00:01; 3,5
alias:      brain  11,4; 22,1; 33,6
alias:      jake   4,7; 8,9; 14,11
alias:      jeff   30:00:00:05:1e:a1:cd:02; 40:00:00:05:1e:a1:cd:04
alias:      jones  7,3; 4,5
alias:      zeus   4,7; 6,8; 9,2
Effective configuration:
No Effective configuration: (No Access)
switch:admin>
switch:admin> zonedeldelete sloth

```

```
switch:admin> cfgsave
```

```
WARNING!!!
```

```
The changes you are attempting to save will render the Effective configuration and the Defined
configuration inconsistent. The inconsistency will result in different Effective Zoning
configurations for switches in the fabric if a zone merge or HA failover happens. To avoid
inconsistency it is recommended to commit the configurations using the 'cfgenable' command.
Do you still want to proceed with saving the Defined zoning configuration only? (yes, y, no, n):
[no] y
```

```
switch:admin>
switch:admin> cfgshow
```

```
Defined configuration:
```

```

zone: matt    zeus; bond; jeff; 4,8
alias:       bawn  3,5
alias:       bolt  10:00:00:02:1f:02:00:01
alias:       bond  10:00:05:1e:a9:20:00:01; 3,5
alias:       brain 11,4; 22,1; 33,6
alias:       jake  4,7; 8,9; 14,11
alias:       jeff  30:00:00:05:1e:a1:cd:02; 40:00:00:05:1e:a1:cd:04
alias:       jones 7,3; 4,5
alias:       zeus  4,7; 6,8; 9,2
Effective configuration:
No Effective configuration: (No Access)

```

## Viewing a zone

The **zoneshow --sort** command displays the defined and effective configurations for a zone. Prior to Fabric OS 7.4.0, the zone members were displayed with sorted D,I pairs. Starting with Fabric OS 7.4.0, the zone members are displayed with D,I pairs and WWNs sorted in ascending order.

Use the following procedure to view a zone in the configuration.

1. Connect to the switch and log in using an account with admin permissions.
2. View the zone information using the **zoneShow** command.

If no parameters are specified, the entire zone database with both the defined and effective configurations is displayed.

## Displaying a zone in a defined configuration example

The following example shows all zones beginning with A, B, or C, in ascending order:

```

switch:admin> zoneshow --sort "[A-C]*"

zone: Blue_zone 1,1; array1; 1,2; array2
zone: Bobs_zone 4,5; 4,6; 4,7; 4,8; 4,9

```

## Displaying the complete zone database example

The following example shows all zones in the zone database:

```

switch:admin> zoneshow
Defined configuration:
cfg:  cfgnpr  npr
cfg:  cfgz   prz; diz; lsan_bb
zone:  diz    1,2; 4,7; 3,2; 1,1
zone:  diz1   00:02:00:00:00:02:00:01; 10,4; 10,6; 10,5
zone:  lsan_bb 30:12:00:05:1e:61:23:8f; 30:00:00:05:1e:61:23:8f
zone:  npr    20:04:00:05:33:88:bb:be; 20:06:00:05:33:88:bb:be;
           20:05:00:05:33:88:bb:be
zone:  prz    00:02:00:00:00:03:00:01; 20:04:00:05:33:88:bb:be;
           20:06:00:05:33:88:bb:be; 20:05:00:05:33:88:bb:be
zone:  upr    00:02:00:00:00:03:00:02; 20:06:00:05:33:88:bb:be;
           20:05:00:05:33:88:bb:be; 20:04:00:05:33:88:bb:be

Effective configuration:
cfg:  cfgz
zone:  diz    1,2
           4,7
           3,2
           1,1
zone:  lsan_bb 30:12:00:05:1e:61:23:8f
           30:00:00:05:1e:61:23:8f
zone:  prz    00:02:00:00:00:03:00:01
           20:04:00:05:33:88:bb:be
           20:06:00:05:33:88:bb:be
           20:05:00:05:33:88:bb:be

```

## Displaying the sorted zone database example

The following example shows all zones in the zone database with sorted D,I pairs and WWNs:

```
switch:admin> zoneshow --sort
Defined configuration:
cfg:  cfgnpr  npr
cfg:  cfgz    prz; diz; lsan_bb
zone: diz     1,1; 1,2; 3,2; 4,7
zone: diz1    00:02:00:00:00:02:00:01; 10,4; 10,5; 10,6
zone: lsan_bb 30:00:00:05:1e:61:23:8f; 30:12:00:05:1e:61:23:8f
zone: npr     20:04:00:05:33:88:bb:be; 20:05:00:05:33:88:bb:be;
              20:06:00:05:33:88:bb:be
zone: prz     00:02:00:00:00:03:00:01; 20:04:00:05:33:88:bb:be;
              20:05:00:05:33:88:bb:be; 20:06:00:05:33:88:bb:be
zone: upr     00:02:00:00:00:03:00:02; 20:05:00:05:33:88:bb:be;
              20:06:00:05:33:88:bb:be; 20:04:00:05:33:88:bb:be

Effective configuration:
cfg:  cfgz
zone: diz     1,1
              1,2
              3,2
              4,7
zone: lsan_bb 30:00:00:05:1e:61:23:8f
              30:12:00:05:1e:61:23:8f
zone: prz     00:02:00:00:00:03:00:01
              20:04:00:05:33:88:bb:be
              20:05:00:05:33:88:bb:be
              20:06:00:05:33:88:bb:be
```

## Viewing zone configuration names without case distinction

Use the following procedure to view selected zone configuration names for a given pattern without case distinction.

1. Connect to the switch and log in using an account with admin permissions.
2. Use the **zoneShow** command to view configuration names.

```
zoneshow[--ic] ["pattern "] [, mode]
```

The following example shows all green zones using pattern search, regardless of the case:

```
switch:admin> zoneshow --ic GREEN*

zone: GREEN 44,4; 21:00:00:20:37:0c:71:02; 8,9
zone: green 2,2; 2,3; 21:00:00:20:37:0c:76:8c
```

## Examining changes in the zone database

Fabric OS allows you to check for and display any differences between the transaction buffer and the committed database by appending the options **--transdiffs** and **--transdiffonly** to the **zoneShow** and **cfgShow** commands.

The options use the format in the following commands:

```
zoneShow --transdiffs
zoneShow --transdiffonly
cfgShow --transdiffs
cfgShow --transdiffonly
```

To reflect the changes made to the zone database (a new zone is added or an existing zone is deleted, or a zone member is added or deleted or any other valid zone database entity is modified), the following notation is used.

- An asterisk (\*) at the start indicates a change in that zone, zone configuration, alias or any other entity in the zone database.

- A plus sign (+) before any entity (an alias or a zone name or a configuration) indicates that it is a newly added entity.
- A minus sign (-) before any entity indicates that this entity has been deleted. If zone members are added as well as deleted in a zone configuration, then a plus sign and a minus sign (+-) will be displayed before the member and a \* sign will be displayed before the zone name.
- A plus sign (+) before any member of an alias or zone name or any other entity indicates this member has been added, and a minus sign (-) indicates the particular member has been deleted. In the case of T1 zones, for inter-fabric links for example, "5,-1" is a valid zone member. Notice that the minus sign (-) comes before the port index. If this was a deleted zone member, it would have been shown as "5,-1". A minus sign (-) before a domain ID indicates that this T1 zone member has been deleted.

Example displaying existing zone database

```
switch:admin> cfgshow
Defined configuration:
cfg: fabric_cfg Blue_zone
zone: Blue_zone
1,1; array1; 1,2; array2
zone: green_zone
1,1; 1,2
alias: array1 21:00:00:20:37:0c:76:8c; 21:00:00:20:37:0c:71:02
alias: array2 21:00:00:20:37:0c:76:22; 21:00:00:20:37:0c:76:28

Effective configuration:
cfg: fabric_cfg
zone: Blue_zone
1,1
21:00:00:20:37:0c:76:8c
21:00:00:20:37:0c:71:02
1,2
```

Example adding a new zone 'red\_zone', deleting "1,1" and adding "6,15" to green\_zone

```
switch:admin> cfgshow --transdiffs
Defined configuration:
cfg: fabric_cfg Blue_zone
zone: Blue_zone
1,1; array1; 1,2; array2
*zone: green_zone
-1,1; 1,2; +6, 15
*zone: +red_zone
5,1; 4,2
alias: array1 21:00:00:20:37:0c:76:8c; 21:00:00:20:37:0c:71:02
alias: array2 21:00:00:20:37:0c:76:22; 21:00:00:20:37:0c:76:28

Effective configuration:
cfg: fabric_cfg
zone: Blue_zone
1,1
21:00:00:20:37:0c:76:8c
21:00:00:20:37:0c:71:02
1,2
```

Example cfgShow --transdiffsonly output for the previous example

```
switch:admin> cfgshow --transdiffsonly
*zone: green_zone -1,1; 1,2; +6,15
*zone: +red_zone 5,1; 4,2
switch:admin>
```

## Validating a zone

Use the following procedure to validate a zone.

1. Connect to the switch and log in using an account with admin permissions.

2. Enter the **cfgShow** command to view the zone configuration objects you want to validate.

```
switch:admin> cfgShow

Defined configuration:
cfg:  USA_cfg Purple_zone; White_zone; Blue_zone
zone: Blue_zone
      1,1; array1; 1,2; array2

zone: Purple_zone
      1,0; loop1

zone: White_zone
```

1,3;1,4

```
alias: array1  21:00:00:20:37:0c:76:8c; 21:00:00:20:37:0c:71:02
alias: array2  21:00:00:20:37:0c:76:22; 21:00:00:20:37:0c:76:28
alias: loop1   21:00:00:20:37:0c:76:85; 21:00:00:20:37:0c:71:df
```

3. Enter the **zone --validate** command to list all zone members that are not part of the current zone enforcement table. Note that zone configuration names are case-sensitive; blank spaces are ignored.

```
switch:admin> zone --validate "White_zone"
```

4. Enter the following command to validate all zones in the zone database in the defined configuration.

```
switch:admin> zone --validate -m 1
Defined configuration:
cfg: cfg1 zone1
cfg: cfg2 zone1; zone2
zone: zone1 1,1; ali1
zone: zone2 1,1; ali2
alias: ali1 10:00:00:05:1e:35:81:7f*; 10:00:00:05:1e:35:81:7d*
alias: ali2 10:00:00:05:1e:35:81:09*; 10:00:00:05:1e:35:81:88*
-----
~ - Invalid configuration
* - Member does not exist
```

The mode flag **-m** can be used to specify the zone database location. Supported mode flag values are:

- 0 - Zone database from the current transaction buffer
- 1 - Zone database stored from the persistent storage
- 2 - Currently effective zone database.

If no mode options are given, the validated output of all three buffers is shown.

If the **-f** option is specified, all the zone members that are not enforceable would be expunged in the transaction buffer. This pruning operation always happens on the transaction and defined buffers. You cannot specify a mode option or specify a zone object as an argument with the **-f** option. This mode flag should be used after the zone has been validated.

If the **-i** option is specified, all zone members for a given pattern are listed without case distinction

Example validating the zone members beginning with gre, regardless of the case

```
switch:admin> zone --validate -i gre*
Defined configuration:
zone: GREEN 44, 4; 21:00:00:20:37:0c:71:02; 8,9
zone: green 2,2*; 2,3*; 21:00:00:20:37:0c:76:8c*
Effective configuration:
zone: green 2,2*
      2,3*
      21:00:00:20:37:0c:76:8c*
-----
```



```

~ - Invalid configuration
* - Member does not exist
# - Invalid usage of broadcast zone

```

## Inconsistencies between the defined and effective configurations

If you edit zone objects in the defined configuration that also exist in the effective configuration and then issue the **cfgSave** command, a warning message stating that a mismatch is observed between the defined and effective configurations is posted, and you are asked to confirm that you want **cfgSave** to continue. If you enter "y", then the updated configuration will be saved; if you enter "n", then the updated configuration will be discarded.

Example of warning message

```

switch: admin> cfgsave
WARNING!!!
The changes you are attempting to save will render the
Effective configuration and the Defined configuration inconsistent.
The inconsistency will result in different Effective Zoning
configurations for switches in the fabric if a zone merge or
HA failover happens. To avoid inconsistency it is recommended to
commit the configurations using the 'cfgenable' command.
Do you want to proceed with saving the Defined
zoning configuration only? (yes, y, no, n): [no] yes

```

If you enter yes, and the **cfgSave** operation completes successfully, then the following RASlog message [ZONE-1062] will be posted. .

```

[ZONE-1062], 620/181, FID 128, WARNING, sw0, Defined and Effective zone configurations are inconsistent,
ltime:2012/09/03-23:18:30:983609

```

You can then either re-enable the updated configuration or revert to the older configuration. If there is no impact to the effective configuration with the latest update to the defined configuration, then the following message will be displayed.

```

You are about to save the Defined zoning configuration. This
action will only save the changes on Defined configuration.
If the update includes changes to one or more traffic isolation
zones, you must issue the 'cfgenable' command for the changes
to take effect.
Do you want to save the Defined zoning configuration only? (yes, y, no, n): [no]

```

## Example of Inconsistent defined and effective configuration warning to use

```

switch: admin> zoneShow
Defined configuration:
cfg:    cfg1    zone1; zone2
zone:   zone1   10:00:00:00:00:00:01; 10:00:00:00:00:00:02
zone:   zone2   1,1; 1,2

Effective configuration:
cfg:    cfg1
zone:   zone1   10:00:00:00:00:00:01
        10:00:00:00:00:00:02
zone:   zone2   1,1; 1,2

switch: admin> zoneadd zone1, 10:00:00:00:00:00:03
switch: admin> cfgsave
WARNING!!!
The changes you are attempting to save will render the
Effective configuration and the Defined configuration inconsistent.
The inconsistency will result in different Effective Zoning
configurations for switches in the fabric if a zone merge or
HA failover happens. To avoid inconsistency it is recommended to
commit the configurations using the 'cfgenable' command.
Do you want to proceed with saving the Defined zoning
configuration only? (yes, y, no, n): [no] y
Updating flash ...

switch:admin> zoneShow
Defined configuration:
cfg:    cfg1    zone1; zone2
zone:   zone1   10:00:00:00:00:00:01; 10:00:00:00:00:00:02; 10:00:00:00:00:00:03
zone:   zone2   1,1; 1,2

Effective configuration:
cfg:    cfg1
zone:   zone1   10:00:00:00:00:00:01; 10:00:00:00:00:00:02
zone:   zone2   1,1; 1,2

```

## Default zoning mode

The default zoning mode controls device access if zoning is not implemented or if there is no effective zone configuration. The default zoning mode has two options:

- All Access -- All devices within the fabric can communicate with all other devices.
- No Access -- Devices in the fabric cannot access any other device in the fabric.

The default zone mode applies to the entire fabric, regardless of switch model.

The default setting is "All Access".

Typically, when you disable the zoning configuration in a large fabric with thousands of devices, the name server indicates to all hosts that they can communicate with each other. Each host can receive an enormous list of PIDs, and ultimately cause other hosts to run out of memory or crash. To ensure that all devices in a fabric do not see each other during a configuration disable operation, set the default zoning mode to No Access.

### NOTE

For switches in large fabrics, the default zone mode should be set to No Access. You cannot disable the effective configuration if the default zone mode is All Access and you have more than 120 devices in the fabric.

## Setting the default zoning mode

### NOTE

You should not change the default zone mode from "No Access" to "All Access" if there is no effective zone configuration and more than 120 devices are connected to the fabric.

Use the following procedure to set the default zoning mode.

1. Connect to the switch and log in using an account with admin permissions.
2. Enter the **cfgActvShow** command to view the current zone configuration.
3. Enter the **defZone** command with one of the following options:

```
defzone --noaccess
```

or

```
defzone --allaccess
```

This command initiates a transaction (if one is not already in progress).

4. Enter the **cfgSave**, **cfgEnable**, or **cfgDisable** command to commit the change and distribute it to the fabric. The change will not be committed and distributed across the fabric if you do not enter one of these commands.

```
switch:admin> defzone --noaccess
```

```
You are about to set the Default Zone access mode to No Access
Do you want to set the Default Zone access mode to No Access ? (yes, y, no, n): [no] y
```

```
switch:admin> cfgsave
```

```
WARNING!!!
```

```
The changes you are attempting to save will render the Effective configuration and the Defined
configuration inconsistent. The inconsistency will result in different Effective Zoning
configurations for switches in the fabric if a zone merge or HA failover happens. To avoid
inconsistency it is recommended to commit the configurations using the 'cfgenable' command.
Do you still want to proceed with saving the Defined
zoning configuration only? (yes, y, no, n): [no] y
```

```
Updating flash ...
```

## Viewing the current default zone access mode

Use the following procedure to view the current default zone access mode.

1. Connect to the switch and log in using an account with admin permissions.
2. Enter the **defZone --show** command.

### NOTE

If you perform a firmware download of an older release, then the current default zone access state will appear as it did prior to the download. For example, if the default zoning mode was No Access before the download, it will remain as No Access afterward.

## Zone database size

The maximum size of a zone database is the upper limit for the defined configuration, and it is determined by the amount of flash memory available for storing the defined configuration.

To display the zone database size, enter **cfgSize**.

The supported maximum zone database size is 2 MB for systems running Brocade DCX 8510 Backbones and X6 Directors. The presence of any other platform reduces the maximum zone database size to 1 MB.

### ATTENTION

In a fabric that has a mix of switches running versions of Fabric OS both earlier and later than version 7.0.0, if you run the **cfgSave** or **cfgEnable** commands from a switch running a pre-7.0.0 version of Fabric OS, a zone database size of 128 KB is may be enforced. Whether this occurs depends on the specific version of pre-Fabric OS 7.0.0 firmware the switches are using. For a detailed list of pre-Fabric OS 7.0.0 firmware compatibility versions, please see the Zoning Compatibility Note in the Release Notes.

**Virtual Fabrics considerations:** If Virtual Fabrics is enabled, the sum of the zone database sizes on all of the logical fabrics must not exceed the maximum size allowed for the chassis (1 MB). The maximum size limit is enforced per-partition, but is not enforced chassis-wide. If the chassis size limit is exceeded, you are not informed of this and unpredictable behavior may occur. It is your responsibility to keep track of the chassis-wide zone database size.

### NOTE

Though Fabric OS does not impose any restriction on the number of members you can have in a zone, it is not advisable to have more than 255 members. Exceeding this limit may lead to unpredictable behavior.

## Zone configurations

You can store a number of zones in a zone configuration database. The maximum number of items that can be stored in the zone configuration database depends on the following criteria:

- Number of switches in the fabric.
- Number of bytes for each item name. The number of bytes required for an item name depends on the specifics of the fabric, but cannot exceed 64 bytes for each item.

When enabling a new zone configuration, ensure that the size of the defined configuration does not exceed the maximum configuration size supported by all switches in the fabric. This is particularly important if you downgrade to a Fabric OS version that supports a smaller zone database than the current Fabric OS. In this scenario, the zone database in the current Fabric OS would have to be changed to the smaller zone database before the downgrade.

You can use the **cfgSize** command to check both the maximum available size and the currently saved size on all switches. If you think you are approaching the maximum, you can save a partially completed zone configuration and use the **cfgSize** command to determine the remaining space. The **cfgSize** command reports the maximum available size on the current switch only. It cannot determine the maximum available size on other switches in the fabric.

### NOTE

The minimum zone database size is 4 bytes, even if the zone database is empty.

For important considerations for managing zoning in a fabric, and more details about the maximum zone database size for each version of the Fabric OS, refer to [Zone database size](#) on page 320.

If you create or make changes to a zone configuration, you must enable the configuration for the changes to take effect.

## Creating a zone configuration

Use the following procedure to create a zone configuration.

1. Connect to the switch and log in using an account with admin permissions.
2. Enter the **cfgCreate** command, using the following syntax:

```
cfgcreate "cfgname ", "member [; member ...]"
```

3. Enter the **cfgSave** command to save the change to the defined configuration.

The **cfgSave** command ends and commits the current zoning transaction buffer to nonvolatile memory. If a transaction is open on a different switch in the fabric when this command is run, the transaction on the other switch is automatically aborted. A message displays on the other switches to indicate that the transaction was aborted.

```
switch:admin> cfgcreate "NEW_cfg", "purplezone; bluezone; greenzone"
```

```
switch:admin> cfgsave
```

```
WARNING!!!
```

```
The changes you are attempting to save will render the Effective configuration and the Defined configuration inconsistent. The inconsistency will result in different Effective Zoning configurations for switches in the fabric if a zone merge or HA failover happens. To avoid inconsistency it is recommended to commit the configurations using the 'cfgenable' command.
```

```
Do you still want to proceed with saving the Defined zoning configuration only? (yes, y, no, n): [no] y
```

## Adding zones to a zone configuration

Use the following procedure to add members to a zone configuration.

1. Connect to the switch and log in using an account with admin permissions.
2. Enter the **cfgAdd** command, using the following syntax:

```
cfgadd "cfgname ", "member [; member ...]"
```

3. Enter the **cfgSave** command to save the change to the defined configuration.

The **cfgSave** command ends and commits the current zoning transaction buffer to nonvolatile memory. If a transaction is open on a different switch in the fabric when this command is run, the transaction on the other switch is automatically aborted. A message displays on the other switches to indicate that the transaction was aborted.

```
switch:admin> cfgadd "newcfg", "bluezone"
```

```
switch:admin> cfgsave
```

```
WARNING!!!
```

```
The changes you are attempting to save will render the Effective configuration and the Defined configuration inconsistent. The inconsistency will result in different Effective Zoning configurations for switches in the fabric if a zone merge or HA failover happens. To avoid inconsistency it is recommended to commit the configurations using the 'cfgenable' command.
```

```
Do you still want to proceed with saving the Defined zoning configuration only? (yes, y, no, n): [no] y
```

## Removing members from a zone configuration

Use the following procedure to remove members from a zone configuration.

1. Connect to the switch and log in using an account with admin permissions.
2. Enter the **cfgRemove** command, using the following syntax:

```
cfgremove "cfgname ", "member [; member ...]"
```

3. Enter the **cfgSave** command to save the change to the defined configuration.

The **cfgSave** command ends and commits the current zoning transaction buffer to nonvolatile memory. If a transaction is open on a different switch in the fabric when this command is run, the transaction on the other switch is automatically aborted. A message displays on the other switches to indicate that the transaction was aborted.

Example

```
switch:admin> cfgremove "NEW_cfg", "purplezone"

switch:admin> cfgsave

WARNING!!!
The changes you are attempting to save will render the Effective configuration and the Defined
configuration inconsistent. The inconsistency will result in different Effective Zoning
configurations for switches in the fabric if a zone merge or HA failover happens. To avoid
inconsistency it is recommended to commit the configurations using the 'cfgenable' command.
Do you still want to proceed with saving the Defined zoning configuration only? (yes, y, no, n):
[no] y
```

## Enabling a zone configuration

The following procedure ends and commits the current zoning transaction buffer to nonvolatile memory. If a transaction is open on a different switch in the fabric when this procedure is run, the transaction on the other switch is automatically aborted. A message displays on the other switches to indicate that the transaction was aborted.

Use the following procedure to enable a zone configuration.

1. Connect to the switch and log in using an account with admin permissions.
2. Enter the **cfgenable** command, using the following syntax:

```
cfgenable "cfgname"
```

3. Enter **y** at the prompt.

```
switch:admin> cfgenable "USA_cfg"

You are about to enable a new zoning configuration.
This action will replace the old zoning configuration with the current configuration selected. If
the update includes changes to one or more traffic isolation zones, the update may result in
localized disruption to traffic on ports associated with the traffic isolation zone changes.
Do you want to enable 'USA_cfg' configuration (yes, y, no, n): [no] y

zone config "USA_cfg" is in effect
Updating flash ...
```

## Disabling a zone configuration

When you disable the current zone configuration, the fabric returns to non-zoning mode. All devices can then access each other or not, depending on the default zone access mode setting.

**NOTE**

If the default zoning mode is set to All Access and more than 120 devices are connected to the fabric, you cannot disable the zone configuration because this would enable All Access mode and cause a large number of requests to the switch. In this situation, set the default zoning mode to No Access prior to disabling the zone configuration. Refer to [Default zoning mode](#) on page 318 for information about setting this mode to No Access.

The following procedure ends and commits the current zoning transaction buffer to nonvolatile memory. If a transaction is open on a different switch in the fabric when this procedure is run, the transaction on the other switch is automatically aborted. A message displays on the other switches to indicate that the transaction was aborted.

Use the following procedure to disable a zone configuration.

1. Connect to the switch and log in using an account with admin permissions.
2. Enter the **cfgDisable** command.
3. Enter **y** at the prompt.

```
switch:admin> cfgdisable
```

```
You are about to disable zoning configuration. This action will disable any previous zoning configuration enabled.
```

```
Do you want to disable zoning configuration? (yes, y, no, n): [no] y
```

## Validating zone members in the zone configuration

Use this procedure to validate the zone members present in the zone configurations.

Validating the zone members helps to know the active and inactive devices logged on to fabric. This procedure adds an indicator "" for the zone members that do not exist in the fabric, and "~" for the zone members with invalid configuration. The zone server updates the details for zone members in the zone database based on the information received from the Name server.

1. Connect to the switch and log in to an account with admin permissions.
2. Enter the **zonestow --validate** command to list the validated zone members in all the zone configurations of the zone database.

Use *pattern* option with **zonestow --validate** to validate a specified zone configuration. The pattern must contain the exact zone configuration name or a portion with the wildcard character (\*) at the end to support a range of characters. This operand is optional.

Use *mode* option with **zonestow --validate** to validate a specified mode of a zone configuration. This operand is optional. The following modes are supported:

- 0 - To display the contents of the transaction buffer
- 1 - To display the contents of the committed defined buffer
- 2 - To display the contents of the effective configuration

The default mode value is 0.

## Validating all zone members example

The following example displays the validated zone members of all the zone configurations of the zone database:

```
switch:admin> zoneshow --validate
Defined configuration:
cfg:   cfg1   zone1; zone10; zone2
zone:  zone1   20:1c:00:05:1e:57:b1:c6*; 20:1d:00:05:1e:57:b1:c6
zone:  zone10  20:1e:00:05:1e:57:b1:c6; 20:1f:00:05:1e:57:b1:c6*
zone:  zone2   20:03:00:05:1e:57:b1:c6; 20:1f:00:05:1e:57:b1:c6*

Effective configuration:
cfg:   cfg1
zone:  zone1   20:1c:00:05:1e:57:b1:c6*
       20:1d:00:05:1e:57:b1:c6
zone:  zone10  20:1e:00:05:1e:57:b1:c6
       20:1f:00:05:1e:57:b1:c6*
zone:  zone2   20:03:00:05:1e:57:b1:c6
       20:1f:00:05:1e:57:b1:c6*
-----
~ - Invalid configuration
* - Member does not exist
# - Invalid usage of broadcast zone
```

## Validating zone members with a zone name example

The following example displays the validated zone members that contain a specified or a part of the zone name:

```
switch:admin> zoneshow --validate zone1
Defined configuration:
zone:  zone1   20:1c:00:05:1e:57:b1:c6*; 20:1d:00:05:1e:57:b1:c6

Effective configuration:
zone:  zone1   20:1c:00:05:1e:57:b1:c6*
       20:1d:00:05:1e:57:b1:c6
-----
~ - Invalid configuration
* - Member does not exist
# - Invalid usage of broadcast zone

switch:admin> zoneshow --validate zone*
Defined configuration:
zone:  zone1   20:1c:00:05:1e:57:b1:c6*; 20:1d:00:05:1e:57:b1:c6
zone:  zone10  20:1e:00:05:1e:57:b1:c6; 20:1f:00:05:1e:57:b1:c6*
zone:  zone2   20:03:00:05:1e:57:b1:c6; 20:1f:00:05:1e:57:b1:c6*
zone:  zone200 20:1d:00:05:1e:57:b1:c6; 20:1f:00:05:1e:57:b1:c6*

Effective configuration:
zone:  zone1   20:1c:00:05:1e:57:b1:c6*
       20:1d:00:05:1e:57:b1:c6
zone:  zone10  20:1e:00:05:1e:57:b1:c6
       20:1f:00:05:1e:57:b1:c6*
zone:  zone2   20:03:00:05:1e:57:b1:c6
       20:1f:00:05:1e:57:b1:c6*
-----
~ - Invalid configuration
* - Member does not exist
# - Invalid usage of broadcast zone
```



## Validating zone members with mode

The following example displays the validated zone members for a specified mode of a zone configuration

```
switch:admin> zoneshow --validate zone200, 0
Defined configuration:
 zone:   zone200   20:1d:00:05:1e:57:b1:c6; 20:1f:00:05:1e:57:b1:c6*
-----
~ - Invalid configuration
* - Member does not exist
# - Invalid usage of broadcast zone
```

## Deleting a zone configuration

Use the following procedure to delete a zone configuration.

1. Connect to the switch and log in using an account with admin permissions.
2. Enter the **cfgDelete** command, using the following syntax:

```
cfgdelete "cfgname"
```

3. Enter the **cfgSave** command to save the change to the defined configuration.

The **cfgSave** command ends and commits the current zoning transaction buffer to nonvolatile memory. If a transaction is open on a different switch in the fabric when this command is run, the transaction on the other switch is automatically aborted. A message displays on the other switches to indicate that the transaction was aborted.

```
switch:admin> cfgdelete "testcfg"

switch:admin> cfgsave

You are about to save the Defined zoning configuration. This
action will only save the changes on Defined configuration.
If the update includes changes to one or more traffic isolation
zones, you must issue the 'cfgenable' command for the changes
to take effect.
Do you want to save the Defined zoning configuration only? (yes, y, no, n): [no]
```

## Deleting invalid zones

Invalid zones can be created by a number of events, including firmware upgrades and downgrades.

Use the following steps to remove an invalid zone.

1. Log into the switch using an account with administrator privileges.
2. Enter **cfgremove "zone\_configuration"** to remove the invalid zone from the zone configuration.
3. Enter **zonedeleter invalid\_zone** to delete the invalid zone from the fabric.
4. Enter **cfgsave** to save the changed configuration.
5. Enter **cfgenable "zone\_configuration"** to re-enable the zone configuration.

The following example removes the invalid zone "dead\_zone" from the "baseline" configuration, deletes the zone, then saves the configuration and reenables it.

```
switch:admin> cfgremove "baseline" "dead_zone"
switch:admin> zonedeleter dead_zone
switch:admin> cfgsave
switch:admin> cfgenable "baseline"
```

For detailed information on the zoning commands used in the procedures, refer to the *Fabric OS Command Reference*.

## Abandoning zone configuration changes

To abandon zone configuration changes, enter the **cfgTransAbort** command.

When this command is executed, all changes since the last save operation (performed with the **cfgSave**, **cfgEnable**, or **cfgDisable** command) are cleared.

Example of assuming that the removal of a member from zone1 was done in error

```
switch:admin> zoneremove "zone1", "3,5"
switch:admin> cfgtransabort
```

## Viewing all zone configuration information

If you do not specify an operand when executing the **cfgShow** command to view zone configurations, then all zone configuration information (both defined and effective) displays. If there is an outstanding transaction, then the newly edited zone configuration that has not yet been saved is displayed. If there are no outstanding transactions, then the committed zone configuration displays.

Use the following procedure to view all zone configuration information.

1. Connect to the switch and log in using an account with admin permissions.
2. Enter the **cfgShow** command with no operands.

Example

```
switch:admin> cfgshow

Defined configuration:
cfg:   USA1   Blue_zone
cfg:   USA_cfg Purple_zone; Blue_zone
zone:  Blue_zone
      1,1; array1; 1,2; array2
zone:  Purple_zone
      1,0; loop1
alias: array1  21:00:00:20:37:0c:76:8c; 21:00:00:20:37:0c:71:02
alias: array2  21:00:00:20:37:0c:76:22; 21:00:00:20:37:0c:76:28
alias: loop1   21:00:00:20:37:0c:76:85; 21:00:00:20:37:0c:71:df

Effective configuration:
cfg:   USA_cfg
zone:  Blue_zone
      1,1
      21:00:00:20:37:0c:76:8c
      21:00:00:20:37:0c:71:02
      1,2
      21:00:00:20:37:0c:76:22
      21:00:00:20:37:0c:76:28
zone:  Purple_zone
      1,0
      21:00:00:20:37:0c:76:85
      21:00:00:20:37:0c:71:df
```

## Viewing selected zone configuration information

Use the following procedure to view the selected zone configuration information.

1. Connect to the switch and log in using an account with admin permissions.
2. Enter the **cfgShow** command and specify a pattern.

```
cfgshow [--ic][,"pattern"] [, mode]
```

Example displaying all zone configurations that start with "Test"

```
switch:admin> cfgshow "Test*"

cfg:  Test1      Blue_zone
cfg:  Test_cfg   Purple_zone; Blue_zone
```

Example displaying all zone configurations that start with "Test", regardless of the case

```
switch:admin> cfgshow --ic "Test*"

cfg:  Test1      Blue_zone
cfg:  Test_2     Red zone; Blue_zone
```

## Viewing the zone aliases in the zone configuration

The following procedure lists the zone aliases, including the user-defined aliases, in the zone configuration.

1. Log in to the switch.
2. View the zone aliases using the **zoneshow --alias [-ic] [pattern]** command.

The **zoneshow --alias** command displays all the zones containing aliases matching the *pattern*. You can use POSIX style regular expression for the alias pattern. The pattern can contain the following:

- A question mark (?) to match any single character.
- An asterisk (\*) to match any string of characters.
- A range of characters to match any character within the range: for example, [0-9] or [a-f].

The following example shows all the zones containing the alias specified when the complete pattern is specified in the command (case sensitive).

```
switch:admin> zoneshow --alias ali1
Defined configuration:
zone:  zone1     ali1
zone:  zone3     2,2; ali1
```

The following example shows all the zones containing the aliases matching the POSIX style regular expression specified in the pattern (case sensitive).

```
switch:admin> zoneshow --alias ali1*
Defined configuration:
zone:  zone1     ali1
zone:  zone3     2,2; ali1
zone:  zone4     21,22; ali12

switch:admin> zoneshow --alias "a*"
zone:  Zone3     ald1
zone:  aliii     aldds
zone:  h1        al; Ali1; dev3
zone:  zone1     ali1
zone:  zone4     dev2; aldds

switch:admin> zoneshow --alias "*a*"
zone:  Zone3     ald1
zone:  aliii     aldds
zone:  h1        al; Ali1; dev3
zone:  zone1     ali1
zone:  zone4     dev2; aldds

switch:admin> zoneshow --alias "*1*"
zone:  Zone3     ald1
zone:  h1        al; Ali1; dev3
zone:  zone1     ali1
```

```

zone: zone2 Ali1

switch:admin> zoneshow --alias "?l?l"
zone: Zone3 ald1
zone: h1 al; Ali1; dev3
zone: zone1 ali1
zone: zone2 Ali1

switch:admin> zoneshow --alias "al[id]l"
zone: Zone3 ald1
zone: zone1 ali1

```

You can also find the list of zones containing the alias matching the pattern that you specify (not case sensitive).

```

switch:admin> zoneshow
Defined configuration:
  cfg:  cfg3      Zone2
zone:  Zone1     dev1; dev2
zone:  Zone2     dev2; DEV3

alias: DEV3      1,8
alias: dev1      1,2
alias: dev2      1,1

Effective configuration:
cfg:  cfg3
zone: Zone2      1,1
      1,8
switch:admin> zoneshow --alias -ic dev3

zone:  Zone2     dev2; DEV3

```

## Viewing the configuration in the effective zone database

Use the following procedure to view the configuration in the effective zone database.

1. Connect to the switch and log in using an account with admin permissions.
2. Enter the **cfgActvShow** command.

```

switch:admin> cfgactvshow

Effective configuration:
cfg:  NEW_cfg
zone: Blue_zone
1,1
21:00:00:20:37:0c:76:8c
21:00:00:20:37:0c:71:02
1,2
21:00:00:20:37:0c:76:22
21:00:00:20:37:0c:76:28
zone: Purple_zone
1,0
21:00:00:20:37:0c:76:85
21:00:00:20:37:0c:71:df

```

## Clearing all zone configurations

Use the following procedure to clear all zone configurations.

1. Connect to the switch and log in using an account with admin permissions.
2. Enter the **cfgClear** command to clear all zone information in the transaction buffer.

**ATTENTION**

Be careful using the **cfgClear** command because it deletes the defined configuration.

```
switch:admin> cfgclear
```

```
The Clear All action will clear all Aliases, Zones, FA Zones and configurations in the Defined
configuration.
Run cfgSave to commit the transaction or cfgTransAbort to cancel the transaction.
Do you really want to clear all configurations? (yes, y, no, n): [no]
```

- Enter one of the following commands, depending on whether an effective zone configuration exists:
  - If no effective zone configuration exists, use the **cfgSave** command.
  - If an effective zone configuration exists, use the **cfgDisable** command to disable and clear the zone configuration in nonvolatile memory for all switches in the fabric.

## Zone object maintenance

The following procedures describe how to copy, delete, and rename zone objects. Depending on the operation, a zone object can be a zone member, a zone alias, a zone, or a zone configuration.

### Copying a zone object

When you copy a zone object, the resulting object has the same name as the original. The zone object can be a zone configuration, a zone alias, or a zone.

Use the following procedure to copy a zone object.

- Connect to the switch and log in using an account with admin permissions.
- Enter the **cfgShow** command to view the zone configuration objects you want to copy.

```
cfgshow "pattern" [, mode
```

For example, to display all zone configuration objects that start with "Test":

```
switch:admin> cfgshow "Test*"
cfg:  Test1      Blue_zone
cfg:  Test_cfg   Purple_zone; Blue_zone
```

- Enter **zone --copy** specifying the zone objects you want to copy along with the new object name.

**NOTE**

Zone configuration names are case-sensitive, and blank spaces are ignored.

```
switch:admin> zone --copy Test1 US_Test1
```

- Enter the **cfgShow** command to verify the new zone object is present.

```
switch:admin> cfgshow "Test*"
cfg:  Test1      Blue_zone
cfg:  Test_cfg   Purple_zone; Blue_zone
switch:admin> cfgShow "US_Test1"
cfg:  US_Test1  Blue_zone
```

- If you want the change preserved when the switch reboots, use **cfgSave** to save it to nonvolatile (flash) memory.
- Enter **cfgEnable** for the appropriate zone configuration to make the change effective.

## Deleting a zone object

The following procedure removes all references to a zone object and then deletes the zone object. The zone object can be a zone member, a zone alias, or a zone.

Use the following procedure to delete a zone object.

1. Connect to the switch and log in using an account with admin permissions.
2. Enter the **cfgShow** command to view the zone configuration objects you want to delete.

```
switch:admin> cfgShow
Defined configuration:
  cfg:  USA_cfg  Purple_zone; White_zone; Blue_zone
  zone: Blue_zone
        1,1; array1; 1,2; array2
  zone: Purple_zone
        1,0; loop1
  zone: White_zone
        1,3; 1,4
  alias: array1  21:00:00:20:37:0c:76:8c; 21:00:00:20:37:0c:71:02
  alias: array2  21:00:00:20:37:0c:76:22; 21:00:00:20:37:0c:76:28
  alias: loop1   21:00:00:20:37:0c:76:85; 21:00:00:20:37:0c:71:df
Effective configuration:
  cfg:  USA_cfg
  zone: Blue_zone
        1,1
        21:00:00:20:37:0c:76:8c
        21:00:00:20:37:0c:71:02
        1,2
        21:00:00:20:37:0c:76:22
        21:00:00:20:37:0c:76:28
  zone: Purple_zone
        1,0
        21:00:00:20:37:0c:76:85
        21:00:00:20:37:0c:71:df
```

3. Enter **zone --expunge** to delete the zone object.

### NOTE

Zone configuration names are case-sensitive and blank spaces are ignored.

```
switch:admin> zone --expunge "White_zone"
You are about to expunge one configuration or member. This action could result in removing many
zoning configurations recursively. [Removing the last member of a configuration removes the
configuration.]
Do you want to expunge the member? (yes, y, no, n): [no] yes
```

4. Enter **yes** at the prompt.
5. Enter **cfgShow** to verify the deleted zone object is no longer present.
6. If you want the change preserved when the switch reboots, use **cfgSave** to save it to nonvolatile (flash) memory.
7. Enter **cfgEnable** for the appropriate zone configuration to make the change effective.

## Renaming a zone object

Use the following procedure to rename a zone object.

1. Connect to the switch and log in using an account with admin permissions.
2. Enter **cfgShow** to view the zone configuration objects you want to rename.

```
switch:admin> cfgShow
Defined configuration:
  cfg:  USA_cfg  Purple_zone; White_zone; Blue_zone
```

```

zone: Blue_zone
  1,1; array1; 1,2; array2
zone: Purple_zone
  1,0; loop1
zone: White_zone
  1,3; 1,4
alias: array1  21:00:00:20:37:0c:76:8c; 21:00:00:20:37:0c:71:02
alias: array2  21:00:00:20:37:0c:76:22; 21:00:00:20:37:0c:76:28
alias: loop1   21:00:00:20:37:0c:76:85; 21:00:00:20:37:0c:71:df

```

3. Enter **zoneObjectRename** to rename zone configuration objects.

#### NOTE

Zone configuration names are case-sensitive and blank spaces are ignored.

```
switch:admin> zoneObjectRename "White_zone", "Purple_zone"
```

4. Enter the **cfgShow** command to verify the renamed zone object is present.
5. If you want the change preserved when the switch reboots, enter the **cfgSave** command to save it to nonvolatile (flash) memory.

#### NOTE

If the renamed zone object is still used in the effective configuration, running **cfgSave** before **cfgEnable** is not allowed.

6. Enter the **cfgEnable** command for the appropriate zone configuration to make the change effective.

## Zone configuration management

You can add, delete, or remove individual elements in an existing zone configuration to create an appropriate configuration for your SAN environment. After the changes have been made, save the configuration to ensure the configuration is permanently saved in the switch and that the configuration is replicated throughout the fabric.

The switch configuration file can also be uploaded to the host for archiving and it can be downloaded from the host to a switch in the fabric. Refer to [Configuration file backup](#) on page 259, [Configuration file restoration](#) on page 261, or the **configUpload** and **configDownload** commands in the *Fabric OS Command Reference* for additional information on uploading and downloading the configuration file.

## Security and zoning

Zones provide controlled access to fabric segments and establish barriers between operating environments. They isolate systems with different uses, protecting individual systems in a heterogeneous environment; for example, when zoning is in secure mode, no merge operations occur.

Brocade Advanced Zoning is configured on the primary fabric configuration server (FCS). The primary FCS switch makes zoning changes and other security-related changes. The primary FCS switch also distributes zoning to all other switches in the secure fabric. All existing interfaces can be used to administer zoning.

You must perform zone management operations from the primary FCS switch using a zone management interface, such as Telnet or Web Tools. You can alter a zone database, provided you are connected to the primary FCS switch.

When two secure fabrics join, the traditional zone merge does not occur. Instead, a zone database is downloaded from the primary FCS switch of the merged secure fabric. When E\_Ports are active between two switches, the name of the FCS server and a zoning policy set version identifier are exchanged between the switches. If the views of the two secure fabrics are the same, the fabric's primary FCS server downloads the zone database and security policy sets to each switch in the fabric. If there is a view conflict, the E\_Ports are segmented due to incompatible security data.

All zones should use frame-based hardware enforcement; the best way to do this is to use WWN identification exclusively for all zoning configurations.

## Zone merging

When a new switch is added to the fabric, it automatically takes on the zone configuration information from the fabric. You can verify the zone configuration on the switch using the procedure described in [Viewing the configuration in the effective zone database](#) on page 328.

If you are adding a switch that is already configured for zoning, clear the zone configuration on that switch before connecting it to the zoned fabric. Refer to [Clearing all zone configurations](#) on page 328 for instructions.

Adding a new fabric that has no zone configuration information to an existing fabric is very similar to adding a new switch. All switches in the new fabric inherit the zone configuration data. If the existing fabric has an effective zone configuration, then the same configuration becomes the effective configuration for the new switches.

Before the new fabric can merge successfully, it must pass the following criteria:

- Before merging - To facilitate merging, check the following before merging switches or fabrics:
  - Defaultzone: The switches must adhere to the default zone merge rules, as described in [Zone merging scenarios](#) on page 333.
  - **Effective and defined zone configuration match** : Ensure that the effective and defined zone configurations match. If they do not match, and you merge with another switch, the merge may be successful, but unpredictable zoning and routing behavior can occur.
- Merging and segmentation

The fabric is checked for segmentation during power-up, when a switch is disabled or enabled, or when a new switch is added.

The zone configuration database is stored in nonvolatile memory by the **cfgSave** command. All switches in the fabric have a copy of this database. When a change is made to the defined configuration, the switch where the changes were made must close its transaction for the changes to be propagated throughout the fabric.

If you have implemented default zoning, you must set the switch you are adding into the fabric to the same default zone mode setting as the rest of the fabric to avoid segmentation.

- Merging rules - Observe these rules when merging zones:
  - Local and adjacent configurations: If the local and adjacent zone database configurations are the same, they will remain unchanged after the merge.
  - Effective configurations: If there is an effective configuration between two switches, the effective zone configurations must match.
  - Zone object naming: If a zoning object has the same name in both the local and adjacent defined configurations, the object types and member lists must match. When comparing member lists, the content and order of the members are important.
  - Objects in adjacent configurations: If a zoning object appears in an adjacent defined configuration, but not in the local defined configuration, the zoning object is added to the local defined configuration. The modified zone database must fit in the nonvolatile memory area allotted for the zone database.
  - Local configuration modification: If a local defined configuration is modified because of a merge, the new zone database is propagated to other the switches within the merge request.
  - TI zones: If there is an effective configuration between two switches and TI zones are present on either switch, the TI zones are not automatically activated after the merge. Check the TI zone enabled status using the **zone --show** command, and if the status does not match across switches, issue the **cfgEnable** command.
- Merging two fabrics



Both fabrics have identical zones and configurations enabled, including the default zone mode. The two fabrics will join to make one larger fabric with the same zone configuration across the newly created fabric.

If the two fabrics have different zone configurations, they will not be merged. If the two fabrics cannot join, the ISL between the switches will segment.

- Merge conflicts

When a merge conflict is present, a merge will not take place and the ISL will segment. Use the **switchShow** or **errDump** commands to obtain additional information about possible merge conflicts, because many non-zone-related configuration parameters can cause conflicts. Refer to the *Fabric OS Command Reference* for detailed information about these commands.

If the fabrics have different zone configuration data, the system attempts to merge the two sets of zone configuration data. If the zones cannot merge, the ISL will be segmented.

A merge is not possible if any of the following conditions exist:

- Configuration mismatch: Zoning is enabled in both fabrics and the zone configurations that are enabled are different in each fabric.
- Type mismatch: The name of a zone object in one fabric is used for a different type of zone object in the other fabric.
- Content mismatch: The definition of a zone object in one fabric is different from the definition of the zone object with the same name in the other fabric.
- Zone database size: The zone database size exceeds the maximum limit of another switch.

#### NOTE

If the zone set members on two switches are not listed in the same order, the configuration is considered a mismatch, resulting in the switches being segmented from the fabric. For example, `cfg1 = z1; z2` is different from `cfg1 = z2; z1`, even though members of the configuration are the same. If zone set members on two switches have the same names defined in the configuration, make sure zone set members are listed in the same order.

#### NOTE

In a large fabric, especially with 1 MB or more zone configuration takes some amount of time for zone merge. This may cause host device to not to discover the target in other end of the fabric for a short duration. This problem may not be seen if the you follow the guidelines of joining the stable fabric one by one with devices offline and ensure that the zone merge operation is completed before enabling the devices.

## Fabric segmentation and zoning

If the connections between two fabrics are no longer available, the fabric segments into two separate fabrics. Each new fabric retains the same zone configuration.

If the connections between two fabrics are replaced and no changes have been made to the zone configuration in either of the two fabrics, then the two fabrics merge back into one single fabric. If any changes that cause a conflict have been made to either zone configuration, then the fabrics may segment.

## Zone merging scenarios

The following tables provide information on merging zones and the expected results:

- [Table 64](#): Defined and effective configurations
- [Table 65](#): Different content
- [Table 66](#): Different names
- [Table 67](#): TI zones

- [Table 68](#): Default access mode
- [Table 72](#): Mixed Fabric OS versions

**TABLE 64** Zone merging scenarios: Defined and effective configurations

Description	Switch A	Switch B	Expected results
<b>Switch A</b> has a defined configuration. <b>Switch B</b> does not have a defined configuration.	defined:cfg1: zone1: ali1; ali2effective: none	defined: none effective: none	Configuration from <b>Switch A</b> to propagate throughout the fabric in an inactive state, because the configuration is not enabled.
<b>Switch A</b> has a defined and effective configuration. <b>Switch B</b> has a defined configuration but no effective configuration.	defined: cfg1zone1: ali1; ali2 effective: cfg1:	defined: cfg1zone1: ali1; ali2 effective: none	Configuration from <b>Switch A</b> to propagate throughout the fabric. The configuration is enabled after the merge in the fabric.
<b>Switch A</b> and <b>Switch B</b> have the same defined configuration. Neither have an effective configuration.	defined: cfg1zone1: ali1; ali2 effective: none	defined: cfg1zone1: ali1; ali2effective: none	No change (clean merge).
<b>Switch A</b> and <b>Switch B</b> have the same defined and effective configuration.	defined: cfg1zone1: ali1; ali2effective: cfg1:	defined: cfg1zone1: ali1; ali2 effective: cfg1:	No change (clean merge).
<b>Switch A</b> does not have a defined configuration. <b>Switch B</b> has a defined configuration.	defined: noneeffective: none	defined:cfg1zone1: ali1; ali2 effective: none	<b>Switch A</b> will absorb the configuration from the fabric.
<b>Switch A</b> does not have a defined configuration. <b>Switch B</b> has a defined configuration.	defined: noneeffective: none	defined:cfg1zone1: ali1; ali2effective: cfg1	<b>Switch A</b> will absorb the configuration from the fabric, with cfg1 as the effective configuration.
<b>Switch A</b> and <b>Switch B</b> have the same defined configuration. Only <b>Switch B</b> has an effective configuration.	defined: cfg1zone1: ali1; ali2effective: none	defined: cfg1zone1: ali1; ali2effective: cfg1	Clean merge, with cfg1 as the effective configuration.
<b>Switch A</b> and <b>Switch B</b> have different defined configurations. Neither have an enabled zone configuration.	defined: cfg2zone2: ali3; ali4 effective: none	defined: cfg1zone1: ali1; ali2effective: none	Clean merge. The new configuration will be a composite of the two.defined: cfg1 zone1: ali1; ali2 cfg2: zone2: ali3; ali4 effective: none
<b>Switch A</b> and <b>Switch B</b> have different defined configurations. <b>Switch B</b> has an effective configuration.	defined: cfg2zone2: ali3; ali4effective: none	defined: cfg1zone1: ali1; ali2effective: cfg1	Clean merge. The new configuration will be a composite of the two, with cfg1 as the effective configuration.
<b>Switch A</b> does not have a defined configuration. <b>Switch B</b> has a defined configuration and an effective configuration, but the effective configuration is different from the defined configuration.	defined: none effective: none	defined: cfg1 zone1: ali1; ali2 effective: cfg1 zone1: ali1; ali2 zone2: ali3, ali4	Clean merge. <b>Switch A</b> absorbs the defined configuration from the fabric, with cfg1 as the effective configuration.  In this case, however, the effective configurations for <b>Switch A</b> and <b>Switch B</b> are different. You should issue a <b>cfgenable</b> from the switch with the proper effective configuration.

**TABLE 65** Zone merging scenarios: Different content

Description	Switch A	Switch B	Expected results
Effective configuration mismatch.	defined: cfg1 zone1: ali1; ali2 effective: cfg1 zone1: ali1; ali2	defined: cfg2 zone2: ali3; ali4 effective: cfg2 zone2: ali3; ali4	Fabric segments due to: Zone Conflict cfg mismatch
Configuration content mismatch.	defined: cfg1 zone1: ali1; ali2 effective: irrelevant	defined: cfg1 zone1: ali3; ali4 effective: irrelevant	Fabric segments due to: Zone Conflict content mismatch

**TABLE 66** Zone merging scenarios: Different names

Description	Switch A	Switch B	Expected results
Same content, different effective cfg name.	defined: cfg1 zone1: ali1; ali2 effective: cfg1 zone1: ali1; ali2	defined: cfg2 zone1: ali1; ali2 effective: cfg2 zone1: ali1; ali2	Fabric segments due to: Zone Conflict cfg mismatch
Same content, different zone name.	defined: cfg1 zone1: ali1; ali2 effective: irrelevant	defined: cfg1 zone2: ali1; ali2 effective: irrelevant	Fabric segments due to: Zone Conflict content mismatch
Same content, different alias name.	defined: cfg1 ali1: A; B effective: irrelevant	defined: cfg1 ali2: A; B effective: irrelevant	Fabric segments due to: Zone Conflict content mismatch
Same alias name, same content, different order.	defined: cfg1 ali1: A; B; C effective: irrelevant	defined: cfg1 ali1: B; C; A effective: irrelevant	Fabric segments due to: Zone Conflict content mismatch
Same name, different types.	effective: zone1: MARKETING	effective: cfg1: MARKETING	Fabric segments due to: Zone Conflict type mismatch
Same name, different types.	effective: zone1: MARKETING	effective: alias1: MARKETING	Fabric segments due to: Zone Conflict type mismatch
Same name, different types.	effective: cfg1: MARKETING	effective: alias1: MARKETING	Fabric segments due to: Zone Conflict type mismatch

**TABLE 67** Zone merging scenarios: TI zones

Description	Switch A	Switch B	Expected results
<b>Switch A</b> does not have Traffic Isolation (TI) zones. <b>Switch B</b> has TI zones.	defined: cfg1 effective: cfg1	defined: cfg1 TI_zone1 effective: cfg1	Clean merge. TI zones are not automatically activated after the merge.
<b>Switch A</b> has TI zones. <b>Switch B</b> has identical TI zones.	defined: cfg1 TI_zone1 effective: cfg1	defined: cfg1 TI_zone1 effective: cfg1	Clean merge. TI zones are not automatically activated after the merge.
<b>Switch A</b> has a TI zone. <b>Switch B</b> has a different TI zone.	defined: cfg1 TI_zone1	defined: cfg1 TI_zone2	Fabric segments due to: Zone Conflict cfg mismatch. Cannot merge switches with different TI zone configurations.
<b>Switch A</b> has Enhanced TI zones. <b>Switch B</b> is running Fabric OS v6.4.0 or later.	defined: cfg1 TI_zone1 TI_zone2	defined: none	Clean merge. TI zones are not automatically activated after the merge.
<b>Switch A</b> has Enhanced TI zones. <b>Switch B</b> is running a Fabric OS version earlier than v6.4.0.	defined: cfg1 TI_zone1 TI_zone2	defined: none	Fabric segments because all switches in the fabric must be running Fabric OS v6.4.0 or later to support Enhanced TI zones.

**TABLE 68** Zone merging scenarios: Default access mode (pre-Fabric OS 7.3.0)

Description	Switch A	Switch B	Expected results
Different default zone access mode settings.	defzone: allaccess	defzone: noaccess	Clean merge -- noaccess takes precedence and defzone configuration from <b>Switch B</b> propagates to fabric.  defzone: noaccess
Same default zone access mode settings.	defzone: allaccess	defzone: allaccess	Clean merge -- defzone configuration is allaccess in the fabric.
	defzone: noaccess	defzone: noaccess	Clean merge -- defzone configuration is noaccess in the fabric.
Effective zone configuration.	No effective configuration.defzone = allaccess	effective: cfg2 defzone: allaccess or noaccess	Clean merge -- effective zone configuration and defzone mode from <b>Switch B</b> propagates to fabric.
Effective zone configuration.	No effective configuration.defzone = noaccess	effective: cfg2 defzone: allaccess	Fabric segments because <b>Switch A</b> has a hidden zone configuration (no access) activated and <b>Switch B</b> has an explicit zone configuration activated.
Effective zone configuration	effective: cfg1 defzone: noaccess	No effective configuration. defzone: noaccess	Clean merge -- effective zone configuration from <b>Switch A</b> propagates to fabric.
Effective zone configuration	effective: cfg1 defzone: allaccess	No effective configuration. defzone: noaccess	Fabric segments. You can resolve the zone conflict by changing defzone to noaccess on <b>Switch 1</b> .

**TABLE 69** Zone merging scenarios: Default access mode (with Fabric OS 7.3.0 or later on initiator and responder)

Description	Switch A (Initiator with FOS 7.3.0)	Switch B (Responder with FOS 7.3.0)	Expected results
Different default zone access mode settings.	defzone: allaccess	defzone: noaccess	Fabric segments due to zone conflict.
	defzone: noaccess	defzone: allaccess	
Same default zone access mode settings.	defzone: allaccess	defzone: allaccess	Clean merge -- defzone configuration is allaccess in the fabric.
	defzone: noaccess	defzone: noaccess	Clean merge -- defzone configuration is noaccess in the fabric.
Initiator has effective zone configuration	effective: cfg1 defzone: allaccess	No effective configuration. defzone: allaccess	Clean merge -- effective zone configuration from <b>Switch A</b> propagates to fabric.
	effective: cfg1 defzone: allaccess	No effective configuration. defzone: noaccess	Fabric segments because <b>Switch B</b> has a hidden zone configuration (no access) activated and <b>Switch A</b> has an explicit zone configuration activated.
	effective: cfg1 defzone: noaccess	No effective configuration. defzone: allaccess	Fabric merges -- effective zone configuration from <b>Switch A</b> propagates to fabric. Allaccess on <b>Switch B</b> changes to noaccess.

**TABLE 69** Zone merging scenarios: Default access mode (with Fabric OS 7.3.0 or later on initiator and responder) (continued)

Description	Switch A (Initiator with FOS 7.3.0)	Switch B (Responder with FOS 7.3.0)	Expected results
	effective: cfg1 defzone: noaccess	No effective configuration. defzone: noaccess	Fabric merges -- effective zone configuration from <b>Switch A</b> propagates to fabric.
Responder has effective zone configuration.	No effective configuration. defzone: allaccess	effective: cfg2 defzone: allaccess	Fabric merges -- effective zone configuration from <b>Switch B</b> propagates to fabric.
	No effective configuration. defzone: allaccess	effective: cfg2 defzone: noaccess	Fabric merges -- effective zone configuration from <b>Switch B</b> propagates to fabric. Allaccess on <b>Switch A</b> changes to noaccess.
	No effective configuration. defzone: noaccess	effective: cfg2 defzone: allaccess	Fabric segments because <b>Switch A</b> has a hidden zone configuration (no access) activated and <b>Switch B</b> has an explicit zone configuration activated.
	No effective configuration. defzone: noaccess	effective: cfg2 defzone: noaccess	Fabric merges -- effective zone configuration from <b>Switch B</b> propagates to fabric.

**TABLE 70** Zone merging scenarios: Default access mode (with Fabric OS 7.3.0 or later on initiator and pre-Fabric OS 7.3.0 on responder)

Description	Switch A (Initiator with FOS 7.3.0)	Switch B (Responder with pre-FOS 7.3.0)	Expected results
Different default zone access mode settings.	defzone: allaccess	defzone: noaccess	Fabric merges with allaccess on <b>Switch A</b> changes to noaccess.
	defzone: noaccess	defzone: allaccess	Fabric merges with allaccess on <b>Switch B</b> changes to noaccess.
Same default zone access mode settings.	defzone: allaccess	defzone: allaccess	Clean merge -- defzone configuration is allaccess in the fabric.
	defzone: noaccess	defzone: noaccess	Clean merge -- defzone configuration is noaccess in the fabric.
Initiator has effective zone configuration	effective: cfg1 defzone: allaccess	No effective configuration. defzone: allaccess	Clean merge -- effective zone configuration from <b>Switch A</b> propagates to fabric.
	effective: cfg1 defzone: allaccess	No effective configuration. defzone: noaccess	Fabric segments because <b>Switch B</b> has a hidden zone configuration (no access) activated and <b>Switch A</b> has an explicit zone configuration activated.
	effective: cfg1 defzone: noaccess	No effective configuration. defzone: allaccess	Fabric merges -- effective zone configuration from <b>Switch A</b> propagates to fabric. Allaccess on <b>Switch B</b> changes to noaccess.
	effective: cfg1 defzone: noaccess	No effective configuration. defzone: noaccess	Fabric merges -- effective zone configuration from <b>Switch A</b> propagates to fabric.
Responder has effective zone configuration.	No effective configuration. defzone: allaccess	effective: cfg2 defzone: allaccess	Fabric merges -- effective zone configuration from <b>Switch B</b> propagates to fabric.

**TABLE 70** Zone merging scenarios: Default access mode (with Fabric OS 7.3.0 or later on initiator and pre-Fabric OS 7.3.0 on responder) (continued)

Description	Switch A (Initiator with FOS 7.3.0)	Switch B (Responder with pre-FOS 7.3.0)	Expected results
	No effective configuration. defzone: allaccess	effective: cfg2 defzone: noaccess	Fabric merges -- effective zone configuration from <b>Switch B</b> propagates to fabric. Allaccess on <b>Switch A</b> changes to noaccess.
	No effective configuration. defzone: noaccess	effective: cfg2 defzone: allaccess	Fabric segments because <b>Switch A</b> has a hidden zone configuration (no access) activated and <b>Switch B</b> has an explicit zone configuration activated.
	No effective configuration. defzone: noaccess	effective: cfg2 defzone: noaccess	Fabric merges -- effective zone configuration from <b>Switch B</b> propagates to fabric.

**TABLE 71** Zone merging scenarios: Default access mode (with pre-Fabric OS 7.3.0 on initiator and Fabric OS 7.3.0 or later on responder)

Description	Switch A (Initiator with pre-FOS 7.3.0)	Switch B (Responder with FOS 7.3.0)	Expected results
Different default zone access mode settings.	defzone: allaccess	defzone: noaccess	Fabric segments due to zone conflict.
	defzone: noaccess	defzone: allaccess	
Same default zone access mode settings.	defzone: allaccess	defzone: allaccess	Clean merge -- defzone configuration is allaccess in the fabric.
	defzone: noaccess	defzone: noaccess	Clean merge -- defzone configuration is noaccess in the fabric.
Initiator has effective zone configuration	effective: cfg1 defzone: allaccess	No effective configuration. defzone: allaccess	Clean merge -- effective zone configuration from <b>Switch A</b> propagates to fabric.
	effective: cfg1 defzone: allaccess	No effective configuration. defzone: noaccess	Fabric segments because <b>Switch B</b> has a hidden zone configuration (no access) activated and <b>Switch A</b> has an explicit zone configuration activated.
	effective: cfg1 defzone: noaccess	No effective configuration. defzone: allaccess	Fabric merges -- effective zone configuration from <b>Switch A</b> propagates to fabric. Allaccess on <b>Switch B</b> changes to noaccess.
	effective: cfg1 defzone: noaccess	No effective configuration. defzone: noaccess	Fabric merges -- effective zone configuration from <b>Switch A</b> propagates to fabric.
Responder has effective zone configuration.	No effective configuration. defzone: allaccess	effective: cfg2 defzone: allaccess	Fabric merges -- effective zone configuration from <b>Switch B</b> propagates to fabric.
	No effective configuration. defzone: allaccess	effective: cfg2 defzone: noaccess	Fabric merges -- effective zone configuration from <b>Switch B</b> propagates to fabric. Allaccess on <b>Switch A</b> changes to noaccess.
	No effective configuration. defzone: noaccess	effective: cfg2 defzone: allaccess	Fabric segments because <b>Switch A</b> has a hidden zone configuration (no access) activated and <b>Switch B</b> has

**TABLE 71** Zone merging scenarios: Default access mode (with pre-Fabric OS 7.3.0 on initiator and Fabric OS 7.3.0 or later on responder) (continued)

Description	Switch A (Initiator with pre-FOS 7.3.0)	Switch B (Responder with FOS 7.3.0)	Expected results
			an explicit zone configuration activated.
	No effective configuration. defzone: noaccess	effective: cfg2 defzone: noaccess	Fabric merges -- effective zone configuration from <b>Switch B</b> propagates to fabric.

**TABLE 72** Zone merging scenarios: Mixed Fabric OS versions

Description	Switch A	Switch B	Expected results
<b>Switch A</b> is running Fabric OS 7.0.0 or later. <b>Switch B</b> is running a Fabric OS version earlier than 7.0.0.	effective: cfg1 defzone = allaccess	No effective configuration. defzone - noaccess	Fabric segments due to zone conflict.
<b>Switch A</b> is running Fabric OS 7.0.0 or later. <b>Switch B</b> is running a Fabric OS version earlier than 7.0.0.	No effective configuration. defzone = noaccess	effective: cfg2 defzone - allaccess	Fabric segments due to zone conflict.

**NOTE**

When merging mixed versions of Fabric OS where both sides have default zone mode No Access set, the merge results vary depending on which switch initiates the merge.

## Concurrent zone transactions

While working on zone sets, a special workspace is provided to allow you to manipulate the zone sets of your choice. These changes are not put into effect until they are committed to the database. Once they are committed, they will replace the existing active zone sets with the new zone sets or create more zone sets in the defined database. When updates to the zoning database are being made by multiple users, Fabric OS warns you about the situation and allows you to choose which operation will prevail.

Example of how users are warned if there is already a pending zoning transaction in the fabric

```
u30:FID128:admin> zonecreate z2, "2,3"
```

```
WARNING!!
```

```
Multiple open transactions are pending in this fabric. Only one
transaction can be saved. Please abort all unwanted transactions
using the cfgtransabort command. Use the cfgtransshow --opentrans
command to display a list of domains with open transactions
```

If no other transaction is open in this fabric, no message is shown.

of what is shown if there is not a pending zoning transaction in the fabric

```
sw0:FID128:admin> zonecreate z7, "4,5;10,3"
```

```
sw0:FID128:admin>
```

Similar messages are shown for cfgSave and cfgEnable:

```
u30:FID128:admin> cfgenable cfg
```

```
You are about to enable a new zoning configuration.
This action will replace the old zoning configuration with the
current configuration selected. If the update includes changes
```

```

to one or more traffic isolation zones, the update may result in
localized disruption to traffic on ports associated with
the traffic isolation zone changes
Multiple open transactions are pending in this fabric. Only one
transaction can be saved. Please abort all unwanted transactions
using the cfgtransabort command. Use the cfgtransshow --opentrans
command to display a list of domains with open transactions
Do you want to enable 'cfg' configuration (yes, y, no, n): [no
]
u30:FID128:admin> cfgsave

```

```

You are about to save the Defined zoning configuration.
This action will only save the changes on Defined configuration.
Multiple open transactions are pending in this fabric. Only one
transaction can be saved. Please abort all unwanted transactions
using the cfgtransabort command. Use the cfgtransshow --opentrans
command to display a list of domains with open transactions
Do you want to save the Defined zoning configuration only?
(yes, y, no, n): [no] n

```

## Viewing zone database transactions

Enter **cfgtransshow** to list the details of the current database transaction token.

Enter **cfgTransShow--opentrans** to display the local open transaction token details and the list of domains with open transactions. Refer to the *Fabric OS Command Reference* for more details on this command.

The following example shows the output of the **cfgtransshow** command.

```

switch:admin> cfgtransshow

Current transaction token is 0x571010459
It is abortable

```

The following example shows the output with **--opentrans** option.

```

switch:admin> cfgtransshow --opentrans

Current transaction token is 0x3109
It is abortable
Transactions Detect: Capable
Current Open Transactions
Domain List:
-----
1  2  3  4

```

## Peer Zoning

Peer Zoning allows a "principal" device to communicate with the rest of the devices in the zone. The principal device manages a Peer Zone. Other "non-principal" devices in the zone can communicate with the principal device only; they cannot communicate with each other.

Prior to the introduction of Peer Zoning, Single-Initiator Zoning was considered a more efficient zoning method in terms of hardware resources and RSCN volume. However, the added storage requirements of defining a unique zone for each host and target rapidly exceeds zone database size limits. As the number of zones increase, it is difficult to configure and maintain the zones.

One-to-Many Zoning defines a zone having one target and other members as initiators. This approach is easy to manage and uses less storage, but zoning all the initiators together in this manner results in less effective use of hardware resources and greater RSCN traffic.

In a Peer Zone setup, principal to non-principal device communication is allowed, but non-principal to non-principal device communication and principal to principal device communication are not allowed. This approach establishes zoning connections that provide the efficiency of Single-Initiator Zoning with the simplicity and lower memory characteristics of One-to-Many Zoning. Typically,



a Peer Zone has a single principal device and one or more non-principal devices, but configurations having multiple principal devices are allowed. Peer Zones are not mutually exclusive with traditional zones; multiple zoning styles can coexist within the same zoning configuration and fabric.

## Peer Zoning compared to other zoning types

The following types of zoning methods are used in a storage area network (SAN):

FIGURE 30 Single-Initiator Zoning example

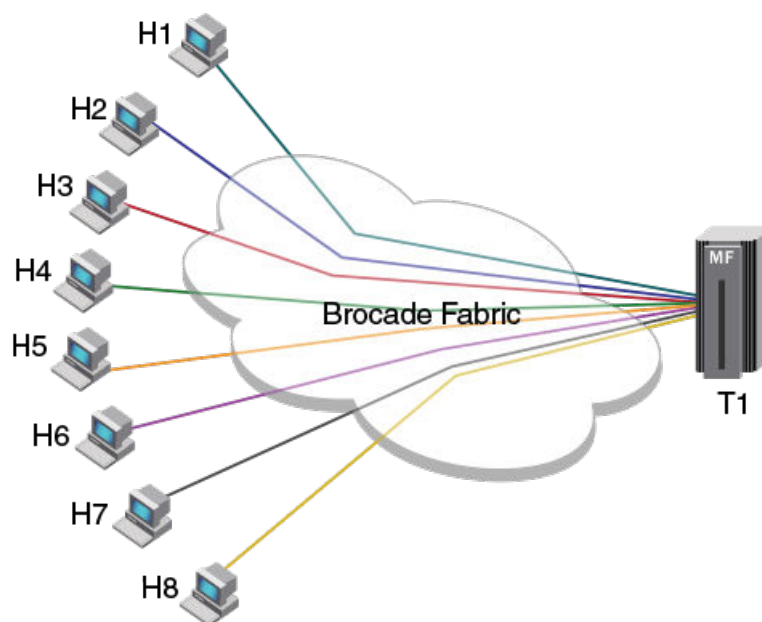

**Single-Initiator Zoning:** Single-Initiator Zoning eliminates the host-to-host visibility, which reduces RSCN traffic. However, the main limitation of Single-Initiator Zoning is that this type of zoning results in creating a large number of zones, which can lead to exceeding the capacity of the zone database size limits. The [Figure 30](#) shows an example of Single-Initiator Zoning with eight zones; one for each host H1 to H8.

FIGURE 31 One-to-many Zoning example

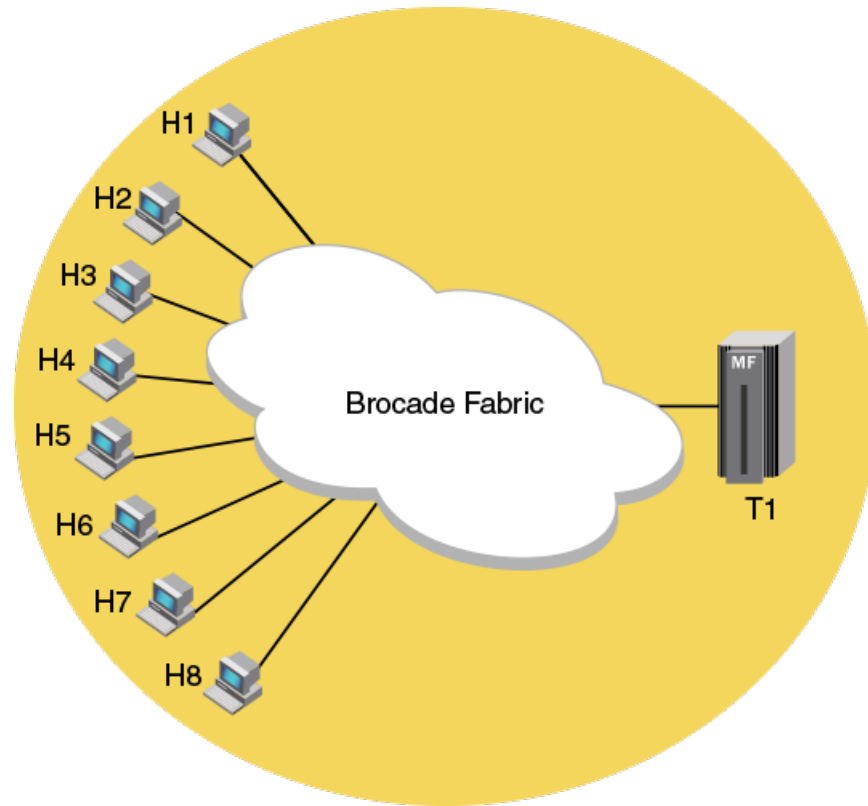

**One-to-many Zoning:** One-to-many Zoning creates a zone with multiple hosts and one target. This approach creates fewer zones as compared to Single-Initiator Zoning, but the host-to-host connectivity generates an extraneous amount of RSCN traffic. The [Figure 31](#) shows an example of One-to-many Zoning where the hosts H1 to H8 are part of the same zone and can communicate with each other.

FIGURE 32 Flat Zoning example

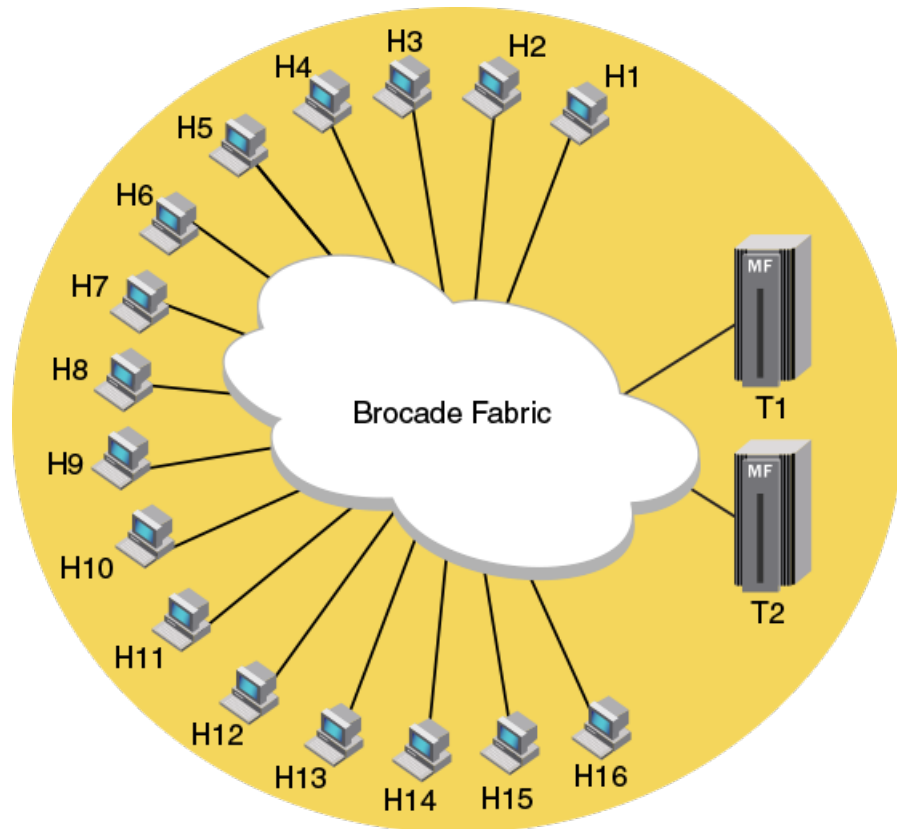

**Flat Zoning:** Flat Zoning consists of a single zone that allows all devices to communicate with each other. This type of zoning supports a large number of hosts. One drawback to this type of zoning is the significant increase in RSCN traffic when compared to other zoning types. The [Figure 32](#) shows an example of Flat Zoning where the hosts H1 to H16 and targets T1 and T2, all form a single zone and can communicate with all other devices in the zone.

FIGURE 33 Peer Zoning example

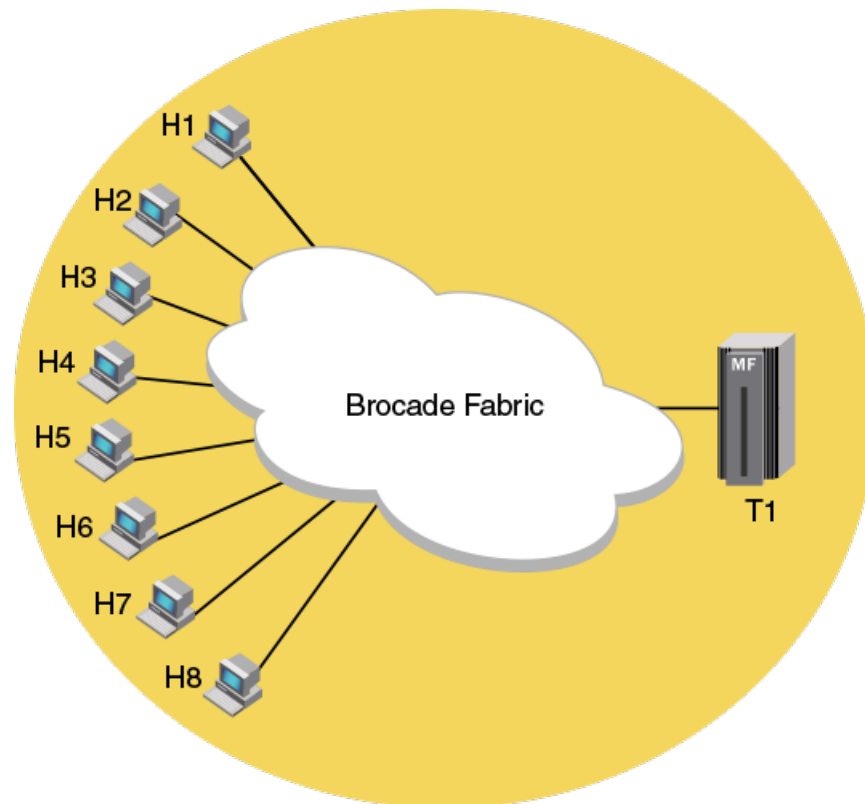

**Peer Zoning:** Using Peer Zoning, a Peer Zone can be created with one device designated as a principal device for that zone. All non-principal devices in the Peer Zone can access only the principal device and cannot communicate with each other. The principal device can communicate with all other non-principal devices. The RSCN traffic generated is the same as for Single-Initiator Zoning. The zone database size is the same as One-to-many Zoning. Peer Zoning results in less RSCN traffic on zoning and device changes, and creates a fewer number of zones. The [Figure 33](#) shows an example where T1 is the principal member of the Peer Zone and hosts H1 to H8 are peer devices.

## Advantages of Peer Zoning

Peer Zoning has the following advantages when compared to Single-Initiator Zoning and One-to-many Zoning types:

- The zone database memory usage is the same as One-to-many Zoning.
- RSCN and hardware resource efficiencies are the same as Single-Initiator Zoning.

## Peer Zone connectivity rules

Peer Zoning adheres to the following connectivity rules:

- Non-principal devices can communicate only with the principal device.
- Non-principal devices cannot communicate with other non-principal devices, unless allowed by some other zone in the active zone set.
- Principal devices cannot communicate with other principal devices, unless allowed by some other zone in the active zone set.

- The maximum number of Peer Zones is determined by the zone database size. Refer to [Zone database size](#) on page 320 for information on zone database sizing.

## Firmware upgrade and downgrade considerations for Peer Zoning

When a switch containing Peer Zones is upgraded to Fabric OS 7.4.0, Peer Zoning connectivity rules are enforced on the devices attached to the upgraded switch. If the device is a member of a Peer Zone, the upgrade can cause disruption.

When a switch containing Peer Zones is downgraded from Fabric OS 7.4.0 to an earlier version, the Peer Zones are treated as regular zones and the zones follow the regular zoning connectivity rules.

All devices in the Peer Zone must be attached to switches running Fabric OS 7.4.0 or later, for the Peer Zoning connectivity rules to be applied. If any device that is part of the Peer Zone is attached to a switch running an earlier version of Fabric OS, the Peer Zone will be treated as a regular zone.

After downgrading to an earlier version of Fabric OS, Peer Zoning connectivity rules remain on the switch until a port of the Peer Zone device is toggled or a new zoning configuration is committed. In such a case, the regular zoning rules apply to the Peer Zones.

## LSAN and QoS Peer Zoning considerations

LSAN and QoS Peer Zoning are supported.

LSAN Peer Zoning is supported on Edge to edge and Edge to backbone topologies. Once the zoning configuration is enabled, Peer Zoning rules are followed

QoS Peer Zones are supported as long as the zone name has the prefix "QOSH" or "QOSL" in the zone name. Refer to [QoS](#) on page 388 for more information.

## Peer Zone configuration

Peer Zones are configured and managed using zone commands with the **--peerzone** option.

In the Peer Zone, devices must be identified as either WWN or D.I devices. Mixing WWN and D.I device identification within a single Peer Zone is not allowed. Aliases are not supported as devices for a Peer Zone.

## Creating Peer Zones

To create a Peer Zone configuration, complete the following steps.

1. Connect to the switch and log in using an account with admin permissions.
2. Create Peer Zones using the **zonecreate --peerzone** command. The **-members** operand is optional.

The following example creates two Peer Zones. The first Peer Zone is called "peerzone\_wwn\_mbrs", which contains "10:00:00:00:01:1e:20:20" as the principal device and "10:00:00:02:1f:02:00:01" and "10:00:05:1e:a9:20:00:01" as the non-principal devices. The second Peer Zone is called "peerzone\_di\_mbrs", which contains "10,1" as the principal device and "20,1" and "20,2" as the non-principal devices.

```
switch:admin> zonecreate --peerzone peerzone_wwn_mbrs -principal "10:00:00:00:01:1e:20:20"/
-members "10:00:00:02:1f:02:00:01;10:00:05:1e:a9:20:00:01"

switch:admin> zonecreate --peerzone peerzone_di_mbrs -principal "10,1" -members "20,1;20,2"
```

## Adding devices to a Peer Zone

To add devices to the Peer Zone, complete the following steps.

1. Connect to the switch and log in using an account with admin permissions.
2. Add Peer Zone devices using the **zoneadd --peerzone** command.

The following example adds the device "10:00:05:1e:a9:20:00:02" to "peerzone\_wwn\_mbrs".

```
switch:admin> zoneadd --peerzone peerzone_wwn_mbrs -members "10:00:05:1e:a9:20:00:02"
```

## Replacing a device in a Peer Zone

To replace devices in the Peer Zone, complete the following steps.

1. Connect to the switch and log in using an account with admin permissions.
2. Replace the existing Peer Zone device with a new device using the **zoneobjectreplace** command.

The **zoneobjectreplace** command restricts replacing the Peer Zone property member. A WWN can be replaced with a WWN only and a D,I member can be replaced with a D,I member only.

The following example replaces the device "20:00:00:05:1e:a1:af:b2" with "10:00:00:05:1e:a1:10:c1" in a Peer Zone.

```
switch:admin> zoneobjectreplace "20:00:00:05:1e:a1:af:b2" "10:00:00:05:1e:a1:10:c1"
```

## Removing devices from a Peer Zone

To remove devices from a Peer Zone, complete the following steps.

1. Connect to the switch and log in using an account with admin permissions.
2. Remove devices from a Peer Zone using the **zoneremove --peerzone** command.

Removing the last principal WWN device deletes the Peer Zone.

The following example removes the device "10:00:05:1e:a9:20:00:02" from the "peerzone\_wwn\_mbrs" Peer Zone.

```
switch:admin> zoneremove --peerzone peerzone_wwn_mbrs -members "10:00:05:1e:a9:20:00:02"
```

## Deleting Peer Zones

To delete a Peer Zone, complete the following steps.

1. Connect to the switch and log in using an account with admin permissions.
2. Delete Peer Zones using the **zonedeleter** command.

The following example deletes the "peerzone\_di\_mbrs" Peer Zone.

```
switch:admin> zonedeleter peerzone_di_mbrs
```

## Viewing Peer Zones

To view a Peer Zone configuration, including the devices associated with the Peer Zone, complete the following steps.

1. Connect to the switch and log in to an account.
2. View the Peer Zone configuration contained in the defined and effective zone databases using the **zoneshow --peerzone** command.
  - Use the **all** option to list all Peer Zones in the zone database.

- Use the **user** option to list only the user-created Peer Zones.
- Use the **target** option to list all Target Driven Peer Zones.

For more information about the commands, refer to the *Fabric OS Command Reference*.

The following example displays the Peer Zone configuration using the **all** option to show all the Peer Zones. Property member field is used to distinguish a Peer Zone from a regular zone. Peer Member (s) field lists the non-principal members of the Peer Zone.

```
switch:admin> zoneshow --peerzone all
Defined configuration:
zone: peerzone_di_mbrs
  Property Member: 00:02:00:00:00:02:00:01
  Created by: User
  Principal Member(s):
    10,1
  Peer Member(s):
    20,1; 20,2
zone: peerzone_wnn_mbrs
  Property Member: 00:02:00:00:00:03:00:01
  Created by: User
  Principal Member(s):
    10:00:00:00:01:1e:20:20
  Peer Member(s):
    10:00:00:02:1f:02:00:01; 10:00:05:1e:a9:20:00:01

Effective configuration:
zone: peerzone_wnn_mbrs
  Property Member: 00:02:00:00:00:03:00:01
  Created by: User
  Principal Member(s):
    10:00:00:00:01:1e:20:20
  Peer Member(s):
    10:00:00:02:1f:02:00:01
    10:00:05:1e:a9:20:00:01

1 Peer Zones in Eff Cfg
```

## Target Driven Zoning

Target Driven Zoning is a variant of Peer Zoning. Where a regular Peer Zone is defined by a user-specified configuration, Target Driven Peer Zone is defined by the principal device. This device is usually a storage device, but not always.

Target Driven Zoning manages the zoning using a third-party management interface to manage the device and the switch interactions. To permit a Target Driven Peer Zone, Target Driven Zoning must be enabled on the F\_Port that connects the principal device to the fabric. Refer to the manual for the device used as the principal device to determine the supported commands and options to construct a Target Driven Peer Zone.

FIGURE 34 Target Driven Zoning example

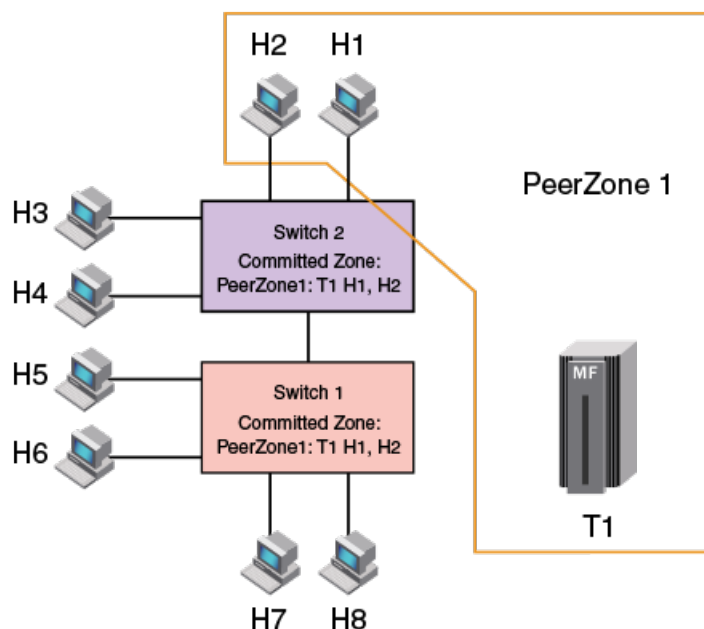

## Limitations and considerations for Target Driven Zoning

The following are the general limitations and considerations for Target Driven Zoning:

- A zone configuration must be created and enabled before a principal device adds or activates a Target Driven Peer Zone. If a zone configuration does not exist or effective zone configuration is disabled, enabling the Target Driven Zoning mode automatically creates a default zone configuration with the name "tdz\_\_\_cfg\_\_\_auto" if the zone database is empty. If any zone object exists in the defined database, the zone configuration is not automatically created.
- The maximum number of devices allowed in a Target Driven Peer Zone, including a principal device is 255.
- The Target Driven Zoning configuration mode must be enabled on the F\_Port to which the principal device is connected.
- Target Driven Peer Zones cannot be created or modified using Brocade Network Advisor (BNA) or the CLI; however, they can be displayed or deleted using BNA or the CLI.
- In Target Driven Peer Zones, devices are identified as WWN devices only.

## Target Driven Zoning configuration

Target Driven Zoning can be configured and managed at the port level using the `portcfgtdz` command.

You must create a zone, add, and enable the zone in the zone database for the Target Driven Zoning. For procedures to create, add, and enable zones in a zone database, refer to [Zone configurations](#) on page 301.

Brocade recommends that all Target Driven Zoning tasks be performed using the zone management interface on the principal device.

## Enabling Target Driven Zoning

Use the management interface on the principal device to create and manage Target Driven Zoning.

To create and enable Target Driven Zoning, complete the following steps.



1. Connect to the switch and log in using an account with admin permissions. By default, Target Driven Zoning configuration is disabled for all ports.
2. Create a zone for Target Driven Zoning using the **zonecreate** command.

The following example creates a zone for Target Driven Zoning.

```
switch:admin> zonecreate "targetzone1", "10:00:00:00:c9:2b:c9:0c;
50:05:07:61:00:5b:62:ed;50:05:07:61:00:49:20:b4"
```

3. Create a zone configuration for Target Driven Zoning in the zone database using the **cfgcreate** command.

The following example creates a zone configuration for Target Driven Zoning.

```
switch:admin> cfgcreate cfgtdz,targetzone1
```

4. Enable the zone for Target Driven Zoning using the **cfgenable** command.

The following example enables the zone for Target Driven Zoning.

```
switch:admin> cfgenable cfgtdz
You are about to enable a new zoning configuration.
This action will replace the old zoning configuration with the
current configuration selected. If the update includes changes
to one or more traffic isolation zones, the update may result in
localized disruption to traffic on ports associated with
the traffic isolation zone changes
Do you want to enable 'cfgtdz' configuration (yes, y, no, n): [no] y
zone config "cfgtdz" is in effect
Updating flash ...
```

5. Enable Target Driven Zoning on a port or port range using the **portcfgtdz --enable** command.

The following example enables Target Driven Zoning. You can enable Target Driven Zoning for a single port, a range of ports, or all ports on a switch.

```
switch:admin> portcfgtdz --enable 8
```

The following example enables Target Driven Zoning on a range of ports.

```
switch:admin> portcfgtdz --enable 8-18
```

The following example enables Target Driven Zoning on all ports.

```
switch:admin> portcfgtdz --enable ""
```

## Disabling Target Driven Zoning

To disable Target Driven Zoning, complete the following steps.

1. Connect to the switch and log in using an account with admin permissions.
2. Disable Target Driven Zoning on a port or port range using the **portcfgtdz --disable** command.

The following example disables Target Driven Zoning on a port.

```
switch:admin> portcfgtdz --disable 10
```

The following example disables Target Driven Zoning on a range of ports.

```
switch:admin> portcfgtdz --disable 2-10
```

The following example disables Target Driven Zoning on all ports.

```
switch:admin> portcfgtdz --disable ""
```

You will get a peer zone change RSCN if an active principle device is attached to the specified port.

## Viewing Target Driven Zoning

To view the Target Driven Zoning status, complete the following steps.

1. Connect to the switch and log in using an account.
2. View Target Driven Zoning status on a port or port range.

The following example displays Target Driven Zoning status on the ports using the `portcfgtdz --show` command.

```
switch:admin> portcfgtdz --show 1-2
Port   Mode
=====
1      ON
2      OFF
```

The following example displays the Target Driven Zoning status on a port using the `portcfgshow` command.

```
switch:admin> portcfgshow 1
Area Number:          1
Octet Speed Combo:   1 (16G|8G|4G|2G)
Speed Level:         AUTO (SW)
AL_PA Offset 13:     OFF
Trunk Port           ON
Long Distance        OFF
VC Link Init         OFF
Locked L_Port        OFF
Locked G_Port        OFF
Disabled E_Port      OFF
Locked E_Port        OFF
ISL R_RDY Mode       OFF
RSCN Suppressed      OFF
Persistent Disable   ON
LOS TOV mode         0 (OFF)
NPIV capability      ON
QOS Port             AE
Port Auto Disable:   OFF
Rate Limit           OFF
EX Port              OFF
Mirror Port          OFF
SIM Port             OFF
Credit Recovery      ON
F_Port Buffers       OFF
E_Port Credits       OFF
Fault Delay:         0 (R_A_TOV)
NPIV PP Limit:       126
NPIV FLOGI Logout:   OFF
CSCTL mode:          OFF
TDZ mode:            ON
D-Port mode:         OFF
D-Port over DWDM:    OFF
Compression:         OFF
Encryption:          OFF
10G/16G FEC:         ON
16G FEC via TTS:     OFF
Non-DFE:             OFF
```

3. (Optional) View the principal device and the non-principal devices in a zone using the `zoneshow --peerzone` command. If the Created by field is User, the zone is a user-created Peer Zone. If the Created by field is Target, the zone is a Target Driven Peer Zone.

The following example displays the complete Peer Zone details.

```
switch:admin> zoneshow --peerzone all
Defined configuration:
zone: peerzone_wnn_mbrs
```

```

Property Member: 00:02:00:00:00:03:00:01
Created by: User
Principal Member(s):
    10:00:00:00:01:1e:20:20
Peer Member(s):
    10:00:00:02:1f:02:00:01; 10:00:05:1e:a9:20:00:01
zone: targetzone1
Property Member: 00:01:00:00:00:03:00:01
Created by: Target
Principal Member(s):
    30:04:00:05:1e:61:23:8f
Peer Member(s):
    10:00:00:02:1f:02:00:05; 10:00:00:02:1f:02:00:12

Effective configuration:
zone: peerzone_wnw_mbrs
Property Member: 00:02:00:00:00:03:00:01
Created by: User
Principal Member(s):
    10:00:00:00:01:1e:20:20
Peer Member(s):
    10:00:00:02:1f:02:00:01
    10:00:05:1e:a9:20:00:01
zone: targetzone1
Property Member: 00:01:00:00:00:03:00:01
Created by: Target
Principal Member(s):
    30:04:00:05:1e:61:23:8f
Peer Member(s):
    10:00:00:02:1f:02:00:05
    10:00:00:02:1f:02:00:12

```

2 Peer Zones in Eff Cfg

The following example displays the Target Driven Peer Zones in a zone.

```

switch:admin> zoneshow --peerzone target
Defined configuration:
zone: targetzone1
Property Member: 00:01:00:00:00:03:00:01
Created by: Target
Principal Member(s):
    30:04:00:05:1e:61:23:8f
Peer Member(s):
    10:00:00:02:1f:02:00:05; 10:00:00:02:1f:02:00:12

Effective configuration:
zone: targetzone1
Property Member: 00:01:00:00:00:03:00:01
Created by: Target
Principal Member(s):
    30:04:00:05:1e:61:23:8f
Peer Member(s):
    10:00:00:02:1f:02:00:05
    10:00:00:02:1f:02:00:12

```

1 Peer Zones in Eff Cfg

## Supported commands for Peer Zones and Target Driven Peer Zones

The regular zone commands are used to configure and manage the Peer Zones and Target Driven Peer Zones.

Peer Zones are managed using the **--peerzone** operand with regular zone commands for some actions. You can manage Target Driven Peer Zones using the regular zone commands, but not all commands are supported. Refer to the following table for the list of commands supported for Peer Zones and Target Driven Peer Zones.

**TABLE 73** Supported commands for Peer Zones and Target Driven Peer Zones

Command	Support for Peer Zones	Support for Target Driven Peer Zones
cfgAdd	Yes	Yes
cfgCreate	Yes	Yes
cfgDelete	Yes	Yes
cfgDisable	Yes	Yes
cfgEnable	Yes	Yes
cfgRemove	Yes	Yes
cfgSave	Yes	Yes
cfgShow	Yes	Yes
zone	No	No
zoneAdd	Yes, using <b>--peerzone</b> operand	No
zoneCreate	Yes, using <b>--peerzone</b> operand	No
zoneDelete	Yes	Yes
zoneObjectCopy	Yes	No
zoneObjectExpunge	No	No
zoneObjectRename	Yes	No
zoneObjectReplace	Yes	No
zoneRemove	Yes, using <b>--peerzone</b> operand	No
zoneShow	Yes, using <b>--peerzone</b> operand	Yes, using <b>--peerzone</b> operand

## Boot LUN zoning

Boot from SAN provides rapid server provisioning, rapid recovery from server failure, improved reliability, and reduced power and cooling. Brocade/QLLogic Host Bus Adapters (HBAs) support boot from SAN in all types of environments. Brocade features make boot from SAN easier to deploy, such as putting a label with the port World Wide Name (pWWN) on the bracket of the HBA and a feature called Fabric-Based Boot LUN Discovery. Fabric-Based Boot LUN Discovery can be deployed in a Brocade SAN only using Brocade/QLLogic HBAs; eliminating the manual process of boot LUN configuration of each HBA from each server console. This capability dramatically improves configuration and reliability, containing operational costs and making the adoption of diskless servers a practical alternative for even large data centers.

### NOTE

IBM UEFI and other UEFI-based servers do not support this unique Brocade feature, because of their different discovery processes.

FIGURE 35 Boot LUN zoning

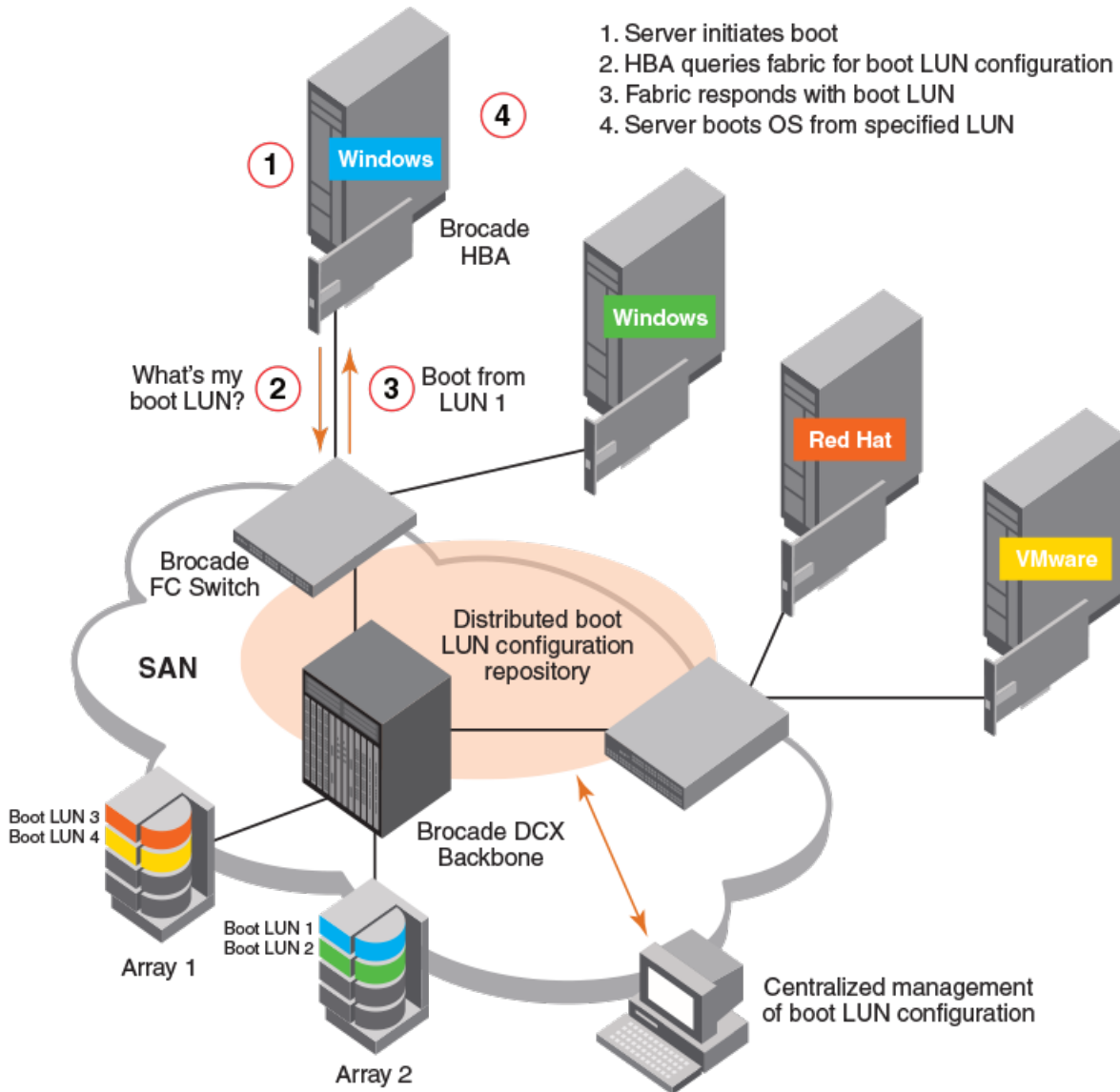

As Boot LUN zones must not be part of a fabric zone configuration, Fabric OS 7.3.0 and later blocks the creation of any zone with a zone name having the format "BFA\_XXXX\_BLUN" (that is, starting with "BFA\_" and ending in "\_BLUN"). Zone names with this configuration are considered to indicate an HBA Boot LUN Zone. As part of the support for peer zoning introduced in Fabric OS 7.3.0, restrictions to protect property members starting with "00:" were added. In Fabric OS 8.0.1 this restriction has been extended to exclude any WWNs that start with "00:00:00:" as this WWN value indicates a Boot LUN zone member.

In Fabric OS 8.0.1 and later, zone configuration rules now only permit creating a Boot LUN zone using the **bootluncfg** command. To enable a Boot LUN configuration, you will need to create a basic zone for the host-target pair using the **bootluncfg** command, and then add this zone object to the zone configuration. This will ensure that the HBA has access to the target. Once this zone is established, Get Zone Member (GZM) queries from the HBA will handle getting the Boot LUN information from the fabric.

Refer to the *Fabric OS Command Reference* for additional information on the **bootluncfg** command.

## Setting up boot LUN zoning

You must configure the server, HBA, and Brocade switch for boot LUN zoning to work. You must also know how to flash the HBA BIOS or upload the latest version of Brocade Fabric OS (FOS) on a Brocade SAN switch or director. Note that Brocade FOS 6.2 or later and HBA BIOS version 1.1 or later are required, and we recommend always using the latest BIOS and FOS version. Other than that, no additional hardware or extra license or software is needed to deploy Fabric-Based Boot LUN Discovery. Use the FOS Command-Line Interface (CLI) for configuration: neither Brocade DCFM nor Brocade Web Tools are required.

## Configuring the server and HBA for BLUN zone

Brocade HBAs are factory-configured to support Fabric-based Boot LUN Discovery in the default BIOS setting. Verify that the BIOS is enabled and that the Boot LUN is set to Auto Discover, as shown in the screen capture below.

FIGURE 36 Boot LUN zoning BIOS setting

```

Brocade's BIOS Config Menu

Adapter Selected
Adapter Model  PCI Bus/Dev/Fn          PWWN
Brocade-815    0C/00/00          10:00:00:05:1E:0F:AA:21

Adapter Settings

BIOS Version   : FCHBA1.1.0.1
NWWN           : 20:00:00:05:1E:0F:AA:21
PWWN           : 10:00:00:05:1E:0F:AA:21

BIOS           - [ Enabled ]
Port Speed     - [ Auto ]
Boot LUN       - [ Auto Discover ]

Press "R" to restore factory defaults

<ESC>-Go back <Alt-Q>- Exit <Alt-S>-Save and exit <PG UP/DOWN>-Next Page
<ENTER>-Select & configure <Up/Down>-Navigate <Left/Right>-Change values

```

## Configuring the Brocade switch for BLUN zone

In addition to zoning and masking, you must configure an additional Boot LUN (BLUN) zone on the switch. At server boot, the Brocade HBA (set to Auto Discover) makes a connection to the switch, retrieves the remote pWWN and the LUN from this BLUN zone, and tries to boot from this LUN.

1. To configure a BLUN zone, use the `bootLunCfg --add` command.

```

switch:admin> bootluncfg --add 11:22:ab:44:44:ff:44:ca \
1b:6c:55:55:55:3a:55:ff 9abc345fa1112410
Operation Successful

```

- To display existing BLUN mappings, use the **bootLunCfg --show** command.

```
switch:admin> bootluncfg --show
00:11:22:33:44:55:66:77
00:00:00:00:aa:bb:cc:dd;00:00:00:01:ee:ff:11:22; \
00:00:00:02:9a:bc:34:5f;00:00:00:03:a1:11:24:10
aa:aa:aa:aa:aa:aa:aa:aa
00:00:00:00:11:11:11:11;00:00:00:01:11:11:11:11; \
00:00:00:02:9a:bc:34:5f;00:00:00:03:a1:11:24:10
bb:aa:aa:aa:aa:aa:aa:aa
00:00:00:00:11:11:11:11;00:00:00:01:11:11:11:11; \
00:00:00:02:9a:bc:34:5f;00:00:00:03:a1:11:24:10
```

- To remove an HBA to BLUN mapping, use the **bootLunCfg --delete** command.

```
switch:admin> bootluncfg --delete 11:22:ab:44:44:ff:44:ca \
1b:6c:55:55:55:3a:55:ff 9abc345fa1112410
Operation Successful
```

- The Brocade Command Line Utility (BCU), loaded with the driver package, provides commands that are comparable to Brocade HCM features for configuring, troubleshooting, and monitoring the HBA and device connection.

Syntax:

```
switch# bcu command --operand synopsis
```

Example:

```
switch#> bcu adapter --query <ad_id>
```

- The **bcu boot -blunZone** command line helps to create the **zoneCreate** command line for the switch Fabric OS, which can then be copied and pasted. Here is the same example but with a different LUN Oxff:

```
switch#> BCU boot --blunZone -c BLUN -p 10:00:00:05:1e:0f:aa:21 -r 50:00:00:e0:d0:44:29:86 -l ff
zonecreate "bfa_100000051e0faa21_blun", "00:00:00:00:50:00:00:e0; 00:00:00:01:d0:44:29:86;
00:00:00:02:00:ff:00:00; 00:00:00:03:00:00:00:00"
```





# Traffic Isolation Zoning

---

• Traffic Isolation Zoning overview.....	357
• FSPF routing rules and traffic isolation.....	359
• Enhanced TI zones.....	361
• General rules for TI zones.....	364
• Limitations and restrictions of Traffic Isolation Zoning.....	366
• Creating a TI zone.....	366
• Modifying TI zones.....	367
• Changing the state of a TI zone.....	368
• Deleting a TI zone.....	368
• Displaying TI zones.....	368
• Enforcing Local TI Filtering.....	369
• Fabric-Level Traffic Isolation in a backbone fabric.....	374
• Virtual Fabrics considerations for Traffic Isolation Zoning.....	381
• Traffic Isolation Zoning over FC routers with Virtual Fabrics.....	383
• Troubleshooting TI zone routing problems.....	385

## Traffic Isolation Zoning overview

Traffic Isolation Zoning allows you to control the flow of interswitch traffic by creating a dedicated path for traffic flowing from a specific set of source ports (N\_Ports).

You might use Traffic Isolation Zoning for the following scenarios:

- To dedicate an ISL to high priority, host-to-target traffic.
- To force high volume, low priority traffic onto a given ISL to limit the effect on the fabric of this high traffic pattern.
- To ensure that requests and responses of FCIP-based applications such as tape pipelining use the same VE\_Port tunnel across a metaSAN.

### NOTE

Traffic Isolation Zoning is an advanced feature, but does not require a license. A strong understanding of Fabric Shortest Path First (FSPF) is required.

Isolating traffic requires that you create a special zone, called a *Traffic Isolation zone* (TI zone). A TI zone indicates that a set of N\_Ports and E\_Ports are to be used only for a specific isolated traffic flow. When a TI zone is activated, the fabric attempts to isolate all inter-switch traffic entering the fabric from a member of the zone to only those E\_Ports that have been included in the zone. The fabric also attempts to exclude traffic not in the TI zone from using E\_Ports within that TI zone.

The illustration below shows a fabric with a TI zone consisting of the following:

- N\_Ports: "1,7", "1,8", "4,5", and "4,6"
- E\_Ports: "1,1", "3,9", "3,12", and "4,7"

The dotted line indicates the dedicated path between the initiator in Domain 1 to the target in Domain 4.

FIGURE 37 Traffic Isolation zone creating a dedicated path through the fabric

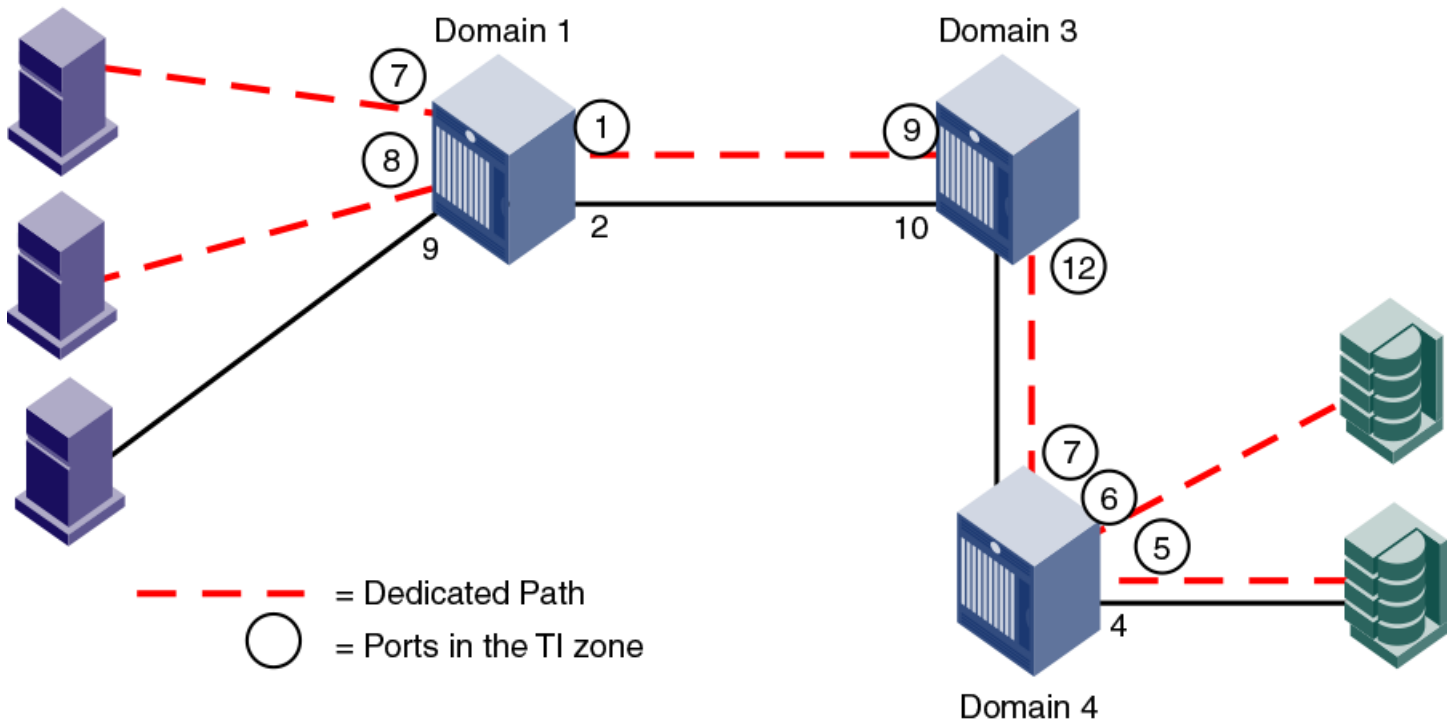

In this illustration, all traffic entering Domain 1 from N\_Ports 7 and 8 is routed through E\_Port 1. Similarly, traffic entering Domain 3 from E\_Port 9 is routed to E\_Port 12, and traffic entering Domain 4 from E\_Port 7 is routed to the devices through N\_Ports 5 and 6. Traffic coming from other ports in Domain 1 would *not* use E\_Port 1, but would use E\_Port 2 instead.

## TI zone failover

A TI zone can have failover enabled or disabled.

Disable failover if you want to guarantee that TI zone traffic uses only the dedicated path, and that no other traffic can use the dedicated path. In other words, an exclusive, members-only path.

Enable failover if you want traffic to have alternate routes if the dedicated path cannot be used, and if you want other traffic to be able to use the dedicated path if the non-dedicated paths are not available.

### ATTENTION

If failover is disabled, use care when planning your TI zones so that non-TI zone devices are not isolated. If this feature is not used correctly, it can cause major fabric disruptions that are difficult to resolve. See [Additional considerations when disabling failover](#) on page 359 for additional information about using this feature.

The following table compares the behavior of traffic when failover is enabled and disabled.

**TABLE 74** Traffic behavior when failover is enabled or disabled in TI zones

Failover enabled	Failover disabled
If the dedicated path is not the shortest path or if the dedicated path is broken, the TI zone traffic will use a non-dedicated path instead.	If the dedicated path is not the shortest path or if the dedicated path is broken, traffic for that TI zone is halted until the dedicated path is fixed. This condition is RAS logged.
Non-TI zone traffic will use the dedicated path if no other paths through the fabric exist, or if the non-dedicated paths are not the shortest paths.	Non-TI zone traffic will never use the dedicated path, even if the dedicated path is the shortest path or if there are no other paths through the fabric. This condition is RAS logged.

For example, in [Figure 37](#) on page 358, if the dedicated ISL between Domain 1 and Domain 3 goes offline, then the following occurs, depending on the failover option:

- If failover is disabled for the TI zone, the TI zone traffic is halted until the ISL between Domain 1 and Domain 3 is back online.
- If failover is enabled for the TI zone, the TI zone traffic is routed from Domain 1 to Domain 3 through E\_Ports "1,2" and "3,10". Also, when TI zone traffic enters the non-TI path, the TI zone traffic continues to flow through that path. In this example, when the TI zone traffic is routed through E\_Ports "1,2" and "3,10", that traffic continues through the non-TI path between domains 3 and 4, even though the TI path between domains 3 and 4 is not broken.

If the non-dedicated ISL between Domain 1 and Domain 3 goes offline, then the following occurs, depending on the failover option:

- If failover is disabled for the TI zone, non-TI zone traffic is halted until the non-dedicated ISL between Domain 1 and Domain 3 is back online.
- If failover is enabled for the TI zone, non-TI zone traffic is routed from Domain 1 to Domain 3 through the dedicated ISL. Also, when non-TI zone traffic enters the TI path, the non-TI zone traffic continues to flow through that path. In this example, when the non-TI zone traffic is routed through E\_Ports "1,1" and "3,9", that traffic continues through E\_Ports "3,12" and "4,7", even though the non-dedicated ISL between domains 3 and 4 is not broken.

### Additional considerations when disabling failover

If failover is disabled, be aware of the following considerations:

- Disabling failover locks the specified route so that only TI zone traffic can use it. Non-TI zone traffic is excluded from using the dedicated path. Ensure that there are also non-dedicated paths through the fabric for all devices that are not in a TI zone.
- If you create a TI zone with E\_Ports only, and no N\_Ports, failover must be enabled. If failover is disabled, the specified ISLs will not be able to route any traffic.
- It is recommended that TI zone definitions and regular zone definitions match. For example, if four N\_Ports are TI zoned together, then these same N\_Ports should also be regularly zoned together.
- It is strongly recommended that the insistent Domain ID feature be enabled. TI zone members are defined by Domain ID and Port Index. If a switch changes its active domain ID, the route defined by the TI zone becomes unknown, breaking the dedicated path. See the **configure** command in the *Fabric OS Command Reference* for information about setting insistent Domain ID.

## FSPF routing rules and traffic isolation

All traffic must use the lowest cost path. FSPF routing rules take precedence over the TI zones, as described in the following situations.

If the dedicated ISL is not the lowest cost path ISL, then the following rules apply:

- If failover is enabled, the traffic path for the TI zone is broken, and TI zone traffic uses the lowest cost path instead.
- If failover is disabled, the TI zone traffic is blocked.

If the dedicated ISL is the only lowest cost path ISL, then the following rules apply:

- If failover is enabled, non-TI zone traffic as well as TI zone traffic uses the dedicated ISL.

- If failover is disabled, non-TI zone traffic is blocked because it cannot use the dedicated ISL, which is the lowest cost path.

For example, in Figure 38, there is a dedicated path between Domain 1 and Domain 3, and another non-dedicated path that passes through Domain 2. If failover is enabled, all traffic will use the dedicated path, because the non-dedicated path is not the shortest path. If failover is disabled, non-TI zone traffic is blocked because the non-dedicated path is not the shortest path.

FIGURE 38 Dedicated path is the only shortest path

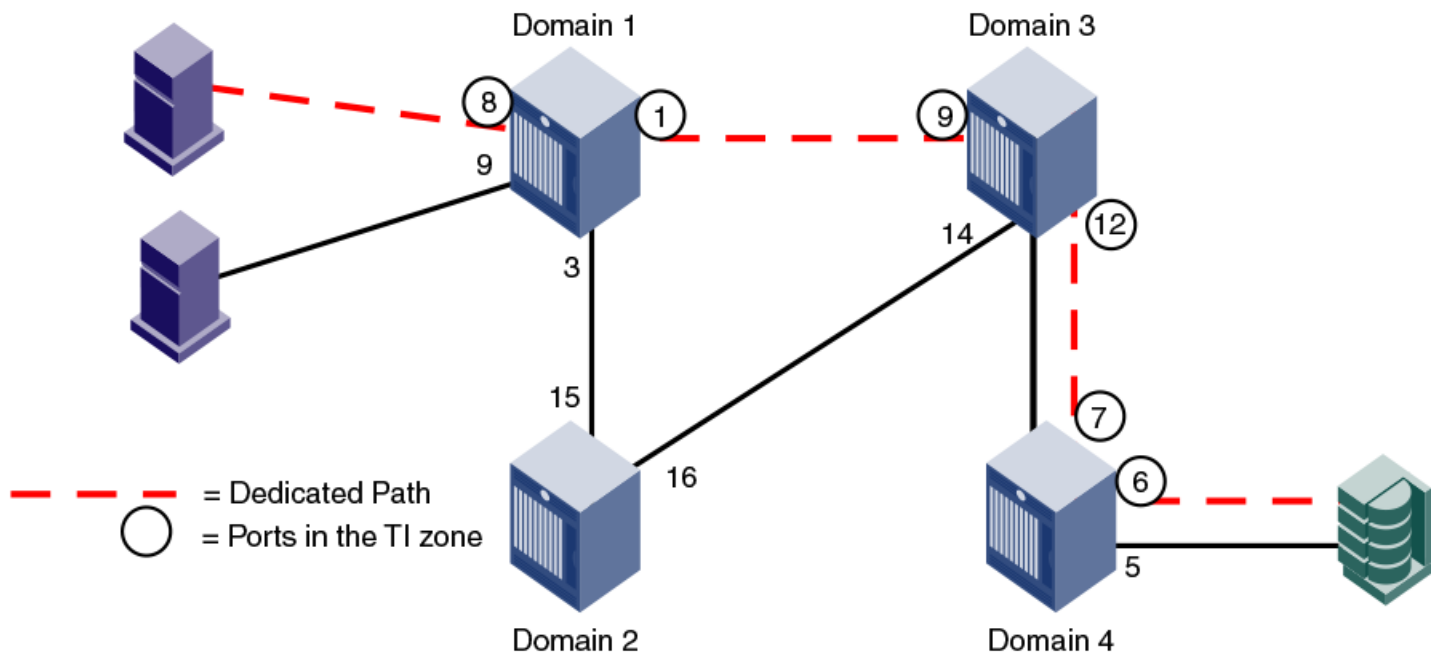

In Figure 39, a dedicated path between Domain 1 and Domain 4 exists, but is not the shortest path. In this situation, if failover is enabled, the TI zone traffic uses the shortest path, even though the E\_Ports are not in the TI zone. If failover is disabled, the TI zone traffic stops until the dedicated path is configured to be the shortest path.

FIGURE 39 Dedicated path is not the shortest path

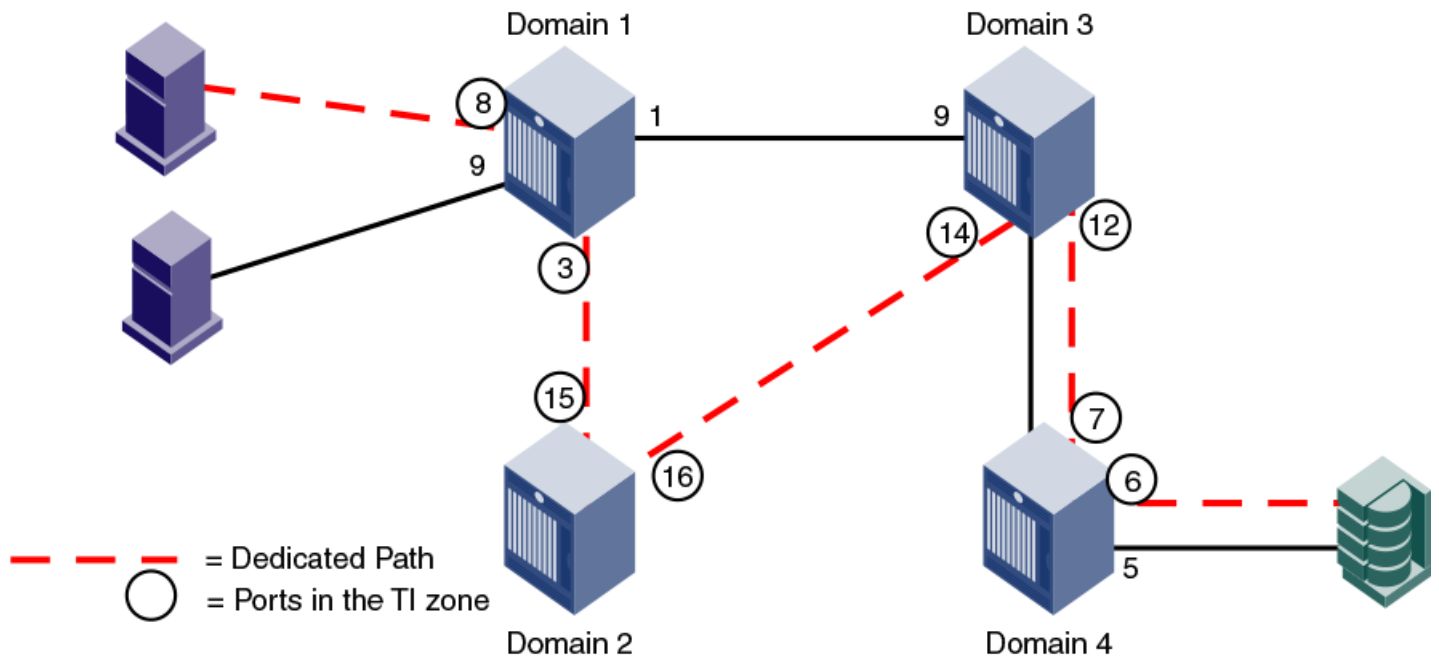

For information about setting or displaying the FSPF cost of a path, see the `linkCost` and `topologyShow` commands in the *Fabric OS Command Reference*.

## Enhanced TI zones

In Fabric OS v6.4.0 and later, ports can be in multiple TI zones at the same time. Zones with overlapping port members are called *enhanced TI zones* (ETIZ). Enhanced TI zones are especially useful in FICON fabrics.

The following figure shows an example of two TI zones. Because these TI zones have an overlapping port (3,8), they are enhanced TI zones.

FIGURE 40 Enhanced TI zones

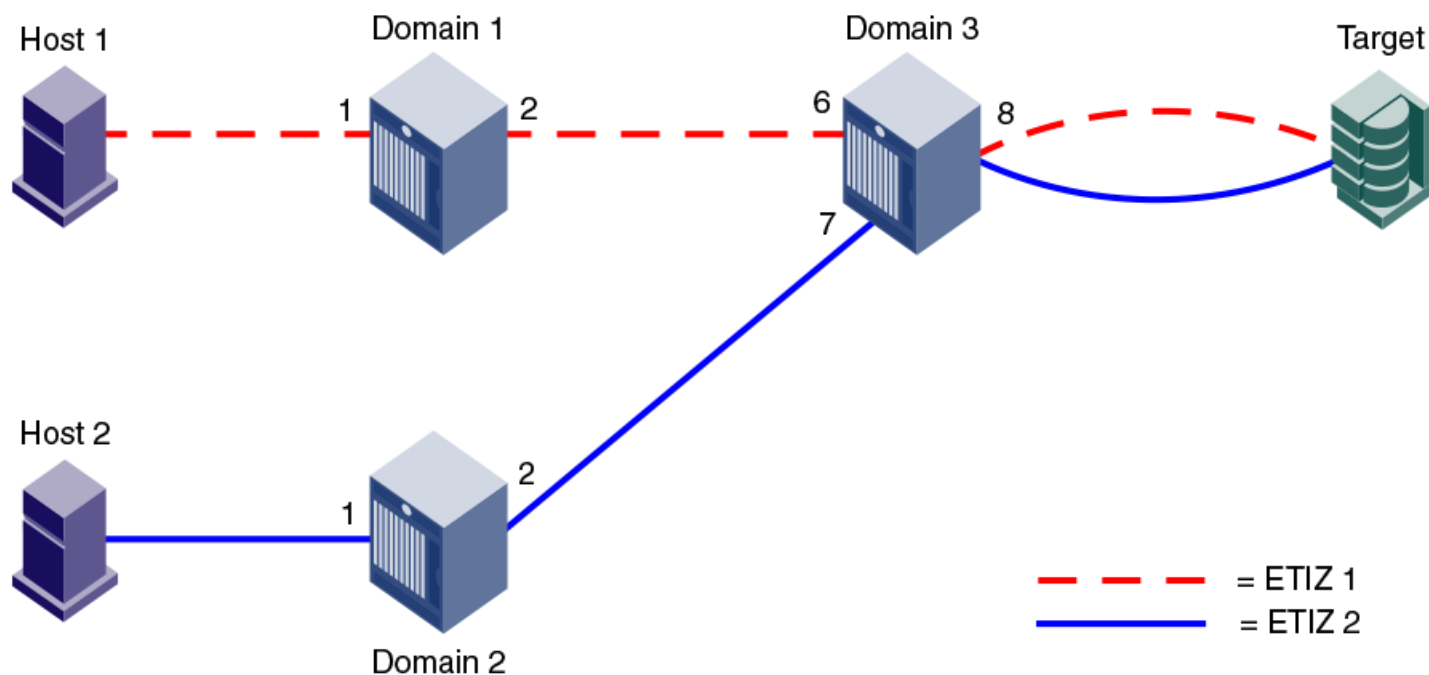

See the *FICON Administrator's Guide* for example topologies using enhanced TI zones.

See [Additional configuration rules for enhanced TI zones](#) on page 365 for more information about enhanced TI zones.

## Invalid configurations with enhanced TI zones

When you create TI zones, ensure that all traffic from a port to all destinations on a remote domain have the same path. Do not create separate paths from a local port to two or more ports on the same remote domain. If failover is disabled with such configurations, traffic loss can occur.

A message is sent to the RASlog if this potential error condition is detected in the TI zone configuration. You can also display a report of existing and potential problems with TI zone configurations, as described in [Troubleshooting TI zone routing problems](#) on page 385.

The following cases are examples of invalid enhanced TI zone configurations.

### Invalid ETIZ configuration: separate paths from a port to devices on same domain

The following figure shows two enhanced TI zones (failover disabled) that are configured incorrectly because there are two paths from a local port (port 8 on Domain 3) to two or more devices on the same remote domain (ports 1 and 4 on Domain 1).

The TI zones are enhanced TI zones because they have an overlapping member (3,8). Each zone describes a different path from the Target to Domain 1. In this case, traffic is routed correctly from Host 1 and Host 2 to the Target; however, traffic from the Target to the Hosts would be dropped in the following manner.

Traffic from (3,8) destined for Domain 1 cannot go through both port 6 and port 7. That is, two exclusive paths have been defined, but only one path will be chosen. If port 6 is chosen (ETIZ 1 path), then frames destined for the Host at Domain 1, N\_Port 4 will be dropped at Domain 1, E\_Port 2, because this Host is not a member of the ETIZ 1 path. Alternatively, if port 7 is chosen (ETIZ 2 path), then frames destined for the Host at Domain 1, N\_Port 1 will be dropped since it is not a member of the ETIZ 2 path.

FIGURE 41 Invalid ETIZ configuration: two paths from one port to two devices on the same remote domain

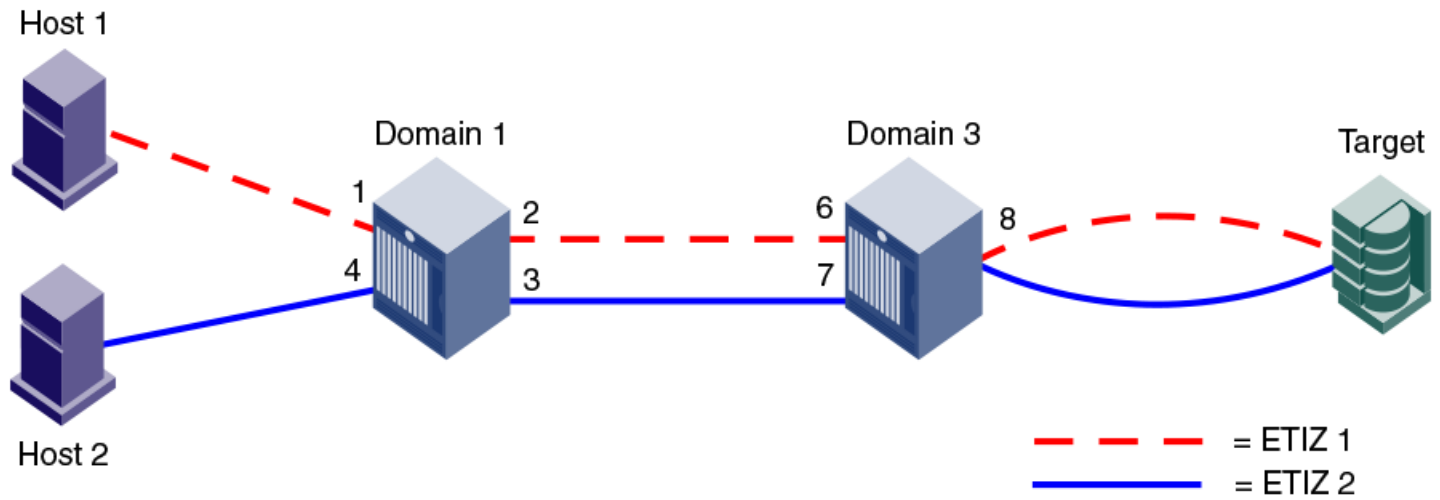

The solution is to overlap the E\_port members [(1,2), (1,3), (3,6), (3,7)] across both ETIZ zones, in addition to the Target at (3,8).

### Invalid ETIZ configuration: separate paths from a single port to the same domain

The following figure shows another example of an invalid ETIZ configuration. In this example, the two hosts are on separate remote domains, but the path to each host goes through the same domain (Domain 1).

This example contains two enhanced TI zones, with port (3,8) as the overlapping member:

- ETIZ 1 contains (1,1), (1,2), (3,6), (3,8)
- ETIZ 2 contains (2,1), (2,2), (1,4), (1,3), (3,7), (3,8)

Both TI zones describe two different paths from the Target on Domain 3 to Hosts on Domain 1 and Domain 2. Traffic from port (3,8) cannot be routed to Domain 1 over both (3,6) and (3,7), only one port/path will be chosen due to the nature of TI zoning. As one example, if E\_Port (3,7) is chosen (ETIZ 2 path), frames destined for the Host at (1,1) will be dropped at E\_Port (1,3) because said Host is not a member of ETIZ 2. Alternatively, if ETIZ 1 path is chosen, i.e., E\_Port (3,6), then traffic to Host 1 at (1,1) can pass, but traffic destined for Host 2 on Domain 2 would be dropped at E\_Port (1,2), since (1,4) is not a member of ETIZ 1.

FIGURE 42 Invalid ETIZ configuration: two paths from one port

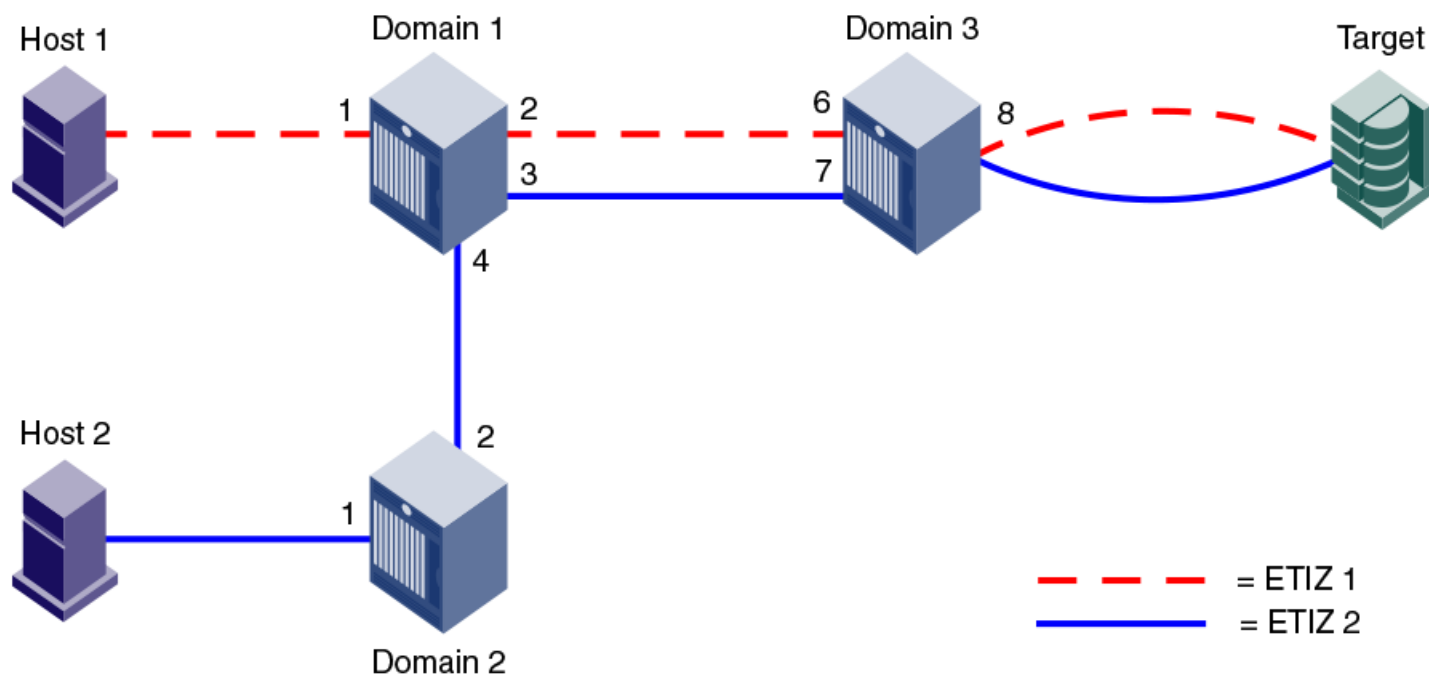

The solution is to overlap the E\_Port members [(1,2),(1,3), (3,6), (3,7)] across both ETIZ zones, in addition to the Target at (3,8); or, overlap all members of both ETIZ zones in this case.

## General rules for TI zones

The following general rules apply to TI zones:

- Ports in a TI zone must belong to switches that run Fabric OS v6.0.0 or later. For TI over FCR zones, all switches and FC routers in both edge and backbone fabrics must be running Fabric OS v6.1.0 or later.
- For the FC8-64 and FC16-64 blades in the Brocade DCX and DCX 8510-8, ports 48-63 can be in a TI zone, only if all switches in that TI zone are running Fabric OS v6.4.0 or later. Ports 48-63 can still be in a failover path for TI traffic. The Brocade DCX-4S and DCX 8510-4 do not have this limitation.
- VE\_Ports can be members of TI zones.
- A TI zone must include E\_Ports and N\_Ports that form a complete, end-to-end route from initiator to target.
- When an E\_Port is a member of a TI zone that E\_Port cannot have its index swapped with another port.
- If multiple E\_Ports are configured that are on the lowest cost route to a domain, the various source ports for that zone are load-balanced across the specified E\_Ports.
- TI zones reside only in the defined configuration and not in the effective configuration. When you make any changes to TI zones, including creating or modifying them, you must enable the effective configuration for the changes to take effect, even if the effective configuration is unchanged.
- A TI zone only provides traffic isolation and is not a "regular" zone.
- Routing rules imposed by TI zones with failover disabled override regular zone definitions. Regular zone definitions should match TI zone definitions.



- FSPF supports a maximum of 16 paths to a given domain. This includes paths in a TI zone.
- To include a trunk group in a TI zone, you must include all ports of the trunk in the TI zone.
- Each TI zone is interpreted by each switch and each switch considers only the routing required for its local ports. No consideration is given to the overall topology and to whether the TI zones accurately provide dedicated paths through the whole fabric.

For example, in the following figure the TI zone was configured incorrectly and E\_Port "3,9" was erroneously omitted from the zone. The domain 3 switch assumes that traffic coming from E\_Port 9 is *not* part of the TI zone and so that traffic is routed to E\_Port 11 instead of E\_Port 12, if failover is enabled. If failover is disabled, the route is broken and traffic stops.

FIGURE 43 TI zone misconfiguration

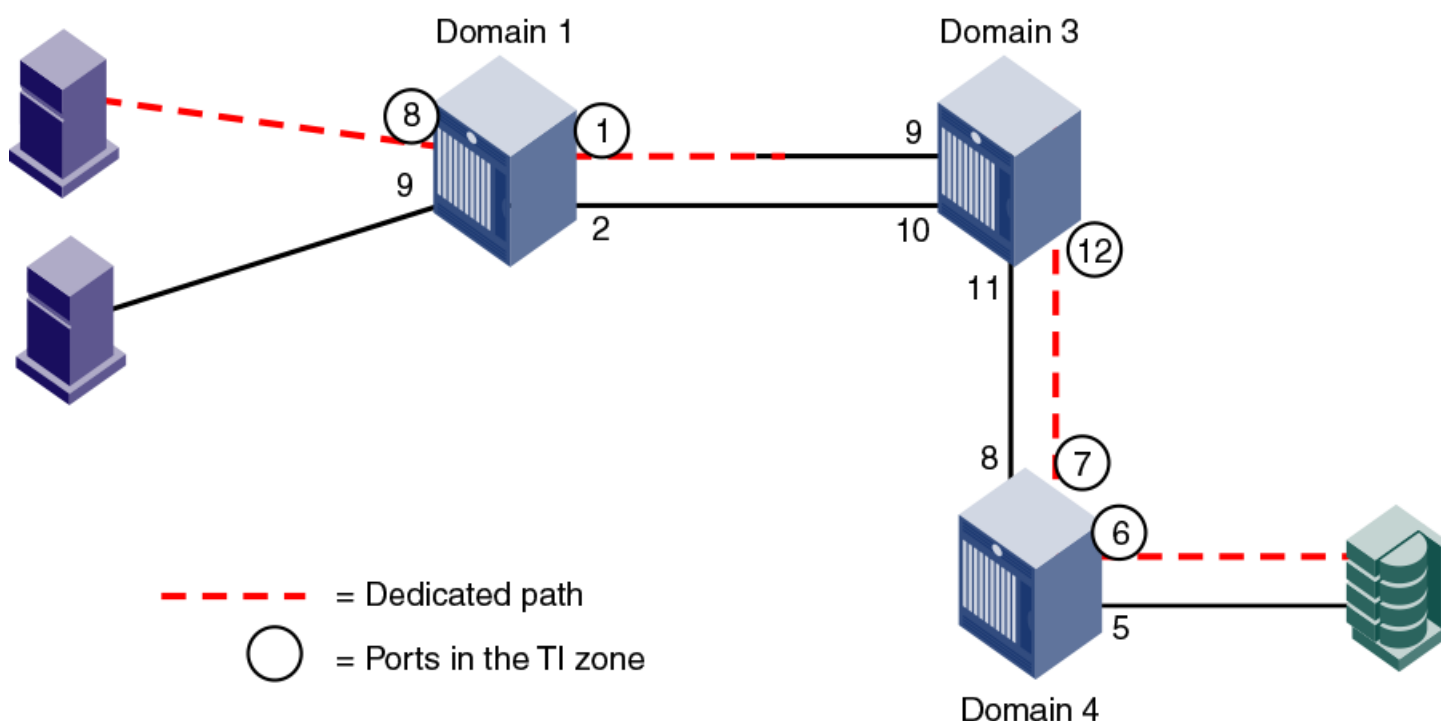

## Additional configuration rules for enhanced TI zones

Enhanced TI zones (ETIZ) have the following additional configuration rules:

- Enhanced TI zones are supported only if every switch in the fabric is ETIZ capable. A switch is ETIZ capable if it meets the following qualifications:
  - The switch must be one of the supported platforms, as listed in the Supported Platforms section.
  - The switch must be running Fabric OS v6.4.0 or later.
- If the fabric contains a switch running an earlier version of Fabric OS, you cannot create an enhanced TI zone. You cannot merge a downlevel switch into a fabric containing enhanced TI zones, and you cannot merge a switch with enhanced TI zones defined into a fabric containing switches that do not support ETIZ.
- Overlapping TI zones must have the same failover type. That is, both must be either failover enabled or failover disabled.

**NOTE**

FC router domains are excluded from the ETIZ platform restrictions. You can create enhanced TI zones with these switches in the fabric.

## Limitations and restrictions of Traffic Isolation Zoning

The following limitations and restrictions apply to Traffic Isolation Zoning:

- A maximum of 255 TI zones can be created in one fabric. A fabric merge resulting in greater than the maximum allowed TI zones results in merge failure and the fabrics are segmented.
- A TI zone can be created using D,I (Domain, Index) notation only, except for TI zones in a backbone fabric, which use port WWNs. See [Traffic Isolation Zoning over FC routers](#) on page 370 for information about TI zones in a backbone fabric.
- To include a trunk group in a TI zone, you must include all ports of the trunk in the TI zone.
- If two N\_Ports are online and have the same shared area, and one of them is configured in a TI zone, then they both must be configured in that same TI zone. One of the online shared area N\_Ports should not remain outside the TI zone unless it is offline, then it may remain outside the TI zone.
- Port swapping is not permitted in TI zones.
- Ports that are in different TI zones cannot communicate with each other if failover is disabled.
- TI zone members that overlap must have the same TI failover policy across all TI zones to which they belong. That is, if an overlapping member is part of a failover-disabled zone, then it can belong only to other TI zones where the policy is also failover-disabled; the member cannot overlap with failover-enabled TI zones.
- TI zones that have members with port index greater than 511 are not supported with Fabric OS versions earlier than v6.4.0. If such a TI zone and Fabric OS version combination is detected, a warning is issued. These configurations are not prevented, but their behavior is unpredictable.
- When you merge two switches, if there is an effective configuration on the switches and TI zones are present on either switch, the TI zones are not automatically activated after the merge. Check the TI zone enabled status using the **zone --show** command, and if the TI Zone Enabled status does not match across switches, issue the **cfgEnable** command.
- Use care when creating TI zones on ICL ports in topologies that span more than two switches connected with ICLs. If a user-defined TI zone breaks the ICL connectivity requirements, a FSPF-1009 RASLOG entry and message is generated to notify you of this error condition.

## Creating a TI zone

You can create TI zones using the **zone --create** command.

```
zone --create -t objtype [-o option list] name -p "port list"
```

The "-t" option specifies the type and should always be specified as "ti" when creating TI zones. When you create a TI zone, you can enable or disable failover mode. By default, failover mode is enabled. You can also set the state of the TI zone to **activated** or **deactivated**. By default the zone state is set to the **activated** state. The following values are used to configure these behaviors using the "-o" option:

Possible values for "-o" option list	Description
<b>f</b>	Create a TI zone with failover enabled; mutually exclusive with the 'n' option
<b>n</b>	Create a TI zone with failover disabled; mutually exclusive with the 'f' option

Possible values for "-o" option list	Description
<b>a</b>	Configure the TI zone as activated; mutually exclusive with the 'd' option
<b>d</b>	Configure the TI zone as deactivated; mutually exclusive with the 'a' option

The "name" option specifies the TI zone name.

The "-p" option lets you define the members of the TI zone, typically the N\_Ports and E\_Ports specified using *Domain* and *Port Index*. For example, given an E\_Port at Port Index 12 on Domain ID 5, the resulting TI zone member would be "5,12".

In addition to running **zone --create** to define a TI zone, the effective zoning configuration must also be re-enabled in order to apply the TI zone.

Use the following procedure to create a TI zone:

1. Connect to the switch and log in using an account with admin permissions.
2. Enter the **zone --create** command, specifying failover mode, activated/deactivated status, TI zone name, and TI zone members (N\_Ports and E\_Ports)
3. Enter the **cfgEnable** command, specifying the current effective configuration.

TI zone updates are not applied until **cfgEnable** is executed

Example for a TI zone named "bluezone" with failover disabled ('n' option) and an "activated" state ('a' option):

```
switch:admin> zone --create -t ti -o an bluezone -p "10,44; 20,44; 10,38; 20,8"
switch:admin> cfgEnable "myConfiguration"
```

Example for a TI zone named "redzone" with failover enabled ('f' option) and a "deactivated" state ('d' option):

```
switch:admin> zone --create -t ti -o fd redzone -p "1,4; 2,4; 1,8; 2,7"
switch:admin> cfgEnable "myConfiguration"
```

## Modifying TI zones

Using the **zone --add** command, you can do the following:

- add ports to an existing TI zone
- change the failover option
- activate or deactivate a TI zone

You must reactivate the effective configuration to apply the changes (**cfgEnable**). Example, changing a TI zone named "greenzone" to failover enabled:

```
switch:admin> zone --add -o f greenzone
switch:admin> cfgEnable "myConfiguration"
```

Using the **zone --remove** command, you can remove ports from existing TI zones. If you remove the last member of a TI zone, the TI zone is deleted. You must reactivate the effective configuration to apply the changes (**cfgEnable**).

Example, removing "5,1" from a TI zone named "silverzone":

```
switch:admin> zone --remove silverzone -p "5,1"
switch:admin> cfgEnable "myConfiguration"
```

### NOTE

If you have overlapping TI zones and you want to change the failover option on these zones, you must first remove the overlapping ports from the zones, then change the failover type, and finally re-add the overlapping members.

## Changing the state of a TI zone

You can change the configured state of an existing TI zone to activated or deactivated. As is the case with other TI zoning operations, you must enable the current effective configuration to apply the change.

1. Connect to the switch and log in using an account with admin permissions.
2. Perform one of the following actions:

- To activate a TI zone, enter the **zone --activate** command.

```
zone --activate name
```

- To deactivate a TI zone, enter the **zone --deactivate** command.

```
zone --deactivate
name
```

3. Enter the **cfgEnable** command to reactivate your current effective configuration and enforce the TI zones.

```
cfgenable "current_effective_configuration"
```

## Deleting a TI zone

Use the **zone --delete** command to delete a TI zone from the defined configuration. This command deletes the entire zone; to only remove port members from a TI zone, use the **zone --remove** command, as described in [Modifying TI zones](#) on page 367.

1. Connect to the switch and log in using an account with admin permissions.
2. Enter the **zone --delete** command.

```
zone --delete name
```

You can delete multiple zones by separating the zone names with a semicolon and enclosing them in quotation marks.

3. Enter the **cfgEnable** command to reactivate your current effective configuration and apply the TI zone delete operation.

```
cfgenable "current_effective_configuration"
```

## Displaying TI zones

Use the **zone --show** command to display information about TI zones. This command displays the following information for each zone:

- Zone name
- E\_Port members
- N\_Port members
- Configured status (the latest status, which may or may not have been activated by **cfgEnable**)
- Enabled status (the status that has been activated by **cfgEnable**)

1. Connect to the switch and log in using an account with admin permissions.
2. Enter the **zone --show** command.

```
zone --show [ name ] [-ascending]
```

## Examples

Example: Displaying information about the TI zone purplezone

```
switch:admin> zone --show purplezone

Defined TI zone configuration: TI Zone Name:    redzone:
Port List:    1,2; 1,3; 3,3; 4,5
Configured Status: Activated / Failover-Enabled
Enabled Status: Activated / Failover-Enabled
```

Example: Displaying information about all TI zones in the defined configuration in ascending order

```
switch:admin> zone --show -ascending

Defined TI zone configuration: TI Zone Name:    bluezone:
Port List:    8,3; 8,5; 9,2; 9,3;
Configured Status: Deactivated / Failover-Disabled
Enabled Status: Activated / Failover-Enabled
TI Zone Name:    greenzone:
Port List:    2,2; 3,3; 4,11; 5,3;
Configured Status: Activated / Failover-Enabled
Enabled Status: Activated / Failover-Enabled
TI Zone Name:    purplezone:
Port List:    1,2; 1,3; 3,3; 4,5;
Configured Status: Activated / Failover-Enabled
Enabled Status: Deactivated / Failover-Enabled
```

Example: Displaying members for the zone "ti\_red" in ascending order

```
switch:admin> zone --show -ascending ti_red
Defined TI zone configuration:
TI Zone Name:    ti_red
Port List:    3,3; 4,4; 5,5
Configured Status: Activated / Failover-Enabled
Enabled Status: Deactivated
```

Example: Displaying members for the zone "TI\_zone", regardless of the case

```
switch:admin> zone --show -ic TI_zone* Defined TI zone configuration:
TI Zone Name:    TI_zone
Port List:    7,8
Configured Status: Activated / Failover-Enabled
Enabled Status: Deactivated
TI Zone Name:    ti_zone
Port List:    3,3
Configured Status: Activated / Failover-Enabled
Enabled Status: Deactivated
```

## Enforcing Local TI Filtering

Local TI Filtering prevents or restricts unwanted traffic flow by enforcing local-to-local TI zone rules.

Prior to Fabric OS 7.4.0, if regular zoning of local-to-local flows did not reflect the same connectivity as the TI zoning, there were cases where the Name Server reported that the connectivity was allowed, but the connectivity was restricted at the routing layers due to TI zoning rules.

Starting with Fabric OS 7.4.0, the Local TI Filtering feature enforces the TI zone rules on local-to-local flows.

Use the **configure** command to configure Local TI Filtering. By default, this feature is disabled. Disable the switch before configuring Local TI Filtering.

## Configuring the Local TI Filtering example

Use Local TI Filtering, listed under Zoning Operation parameters of the **configure** command, to enable or disable the feature.

```
switch:admin> switchdisable
switch:admin> configure

Configure...
.....
Zoning Operation parameters (yes, y, no, n): [no] yes
.....
Local TI Filtering (on, off): [off] on
.....
```

## Traffic Isolation Zoning over FC routers

TI zoning can be used with FC routed fabrics with failover enabled. To achieve end-to-end traffic isolation across the metaSAN, TI zones must be configured at each relevant edge fabric, and the backbone fabric, within the metaSAN.

Some VE\_Port-based features, such as tape pipelining, require the request and corresponding response traffic to traverse the same VE\_Port tunnel across the metaSAN. To ensure that the request and response traverse the same VE\_Port tunnel, you must set up Traffic Isolation zones in the edge and backbone fabrics.

- Set up a TI zone in an edge fabric to guarantee that traffic from a specific device in that edge fabric is routed through a particular EX\_Port or VEX\_Port.
- Set up a TI zone in the backbone fabric to guarantee that traffic between two devices in different fabrics is routed through a particular ISL (VE\_Ports or E\_Ports) in the backbone.

This combination of TI zones in the backbone and edge fabrics ensures that the traffic between devices in different fabrics traverses the same VE\_Port tunnel in a backbone fabric. [Figure 44](#) shows how three TI zones form a dedicated path between devices in different edge fabrics. The backbone fabric can contain one or more FC routers.

FIGURE 44 Traffic Isolation Zoning over FCR

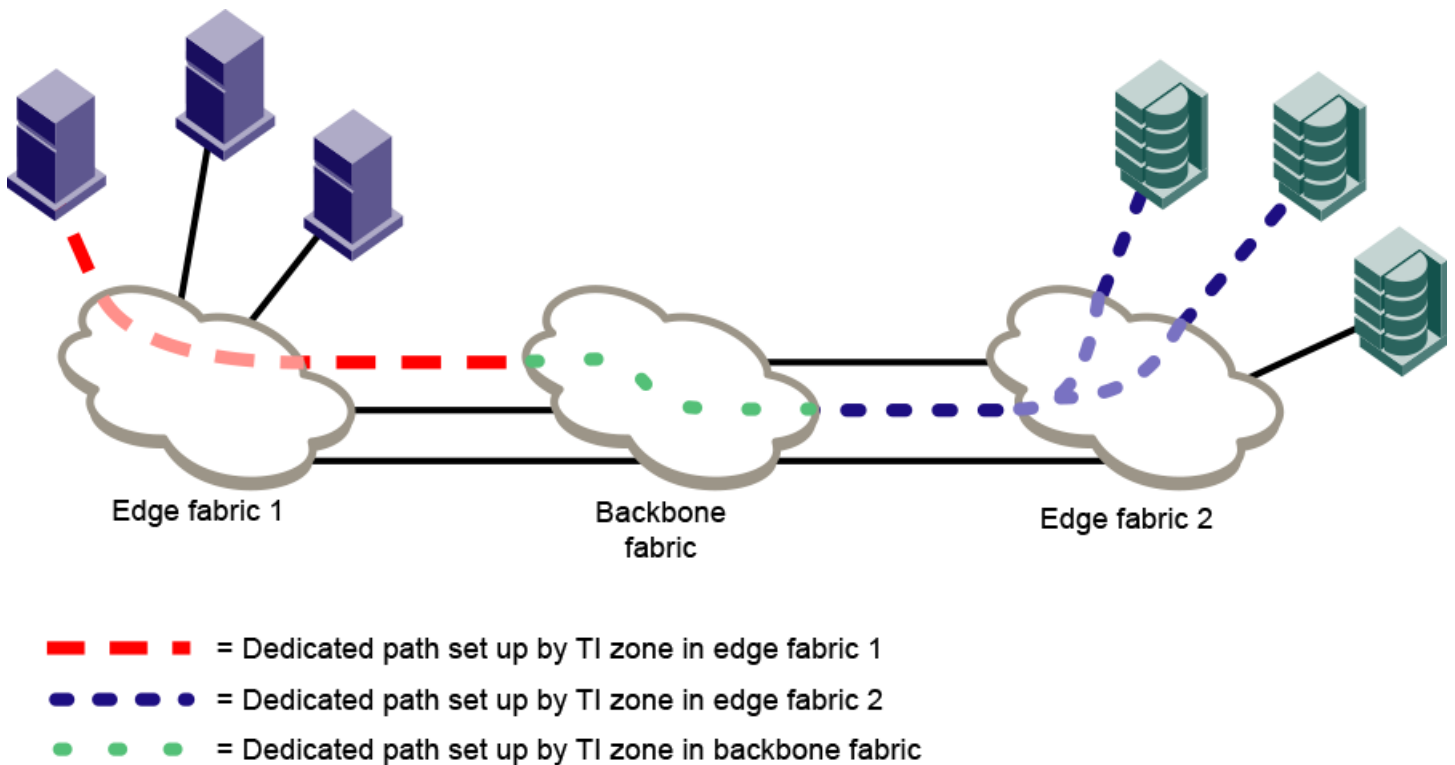

In addition to setting up TI zones, you must also ensure that the devices are in an LSAN zone so that they can communicate with each other.

If failover is enabled and the TI path is not available, an alternate path is used. If failover is disabled and the TI path is not available, then devices are not imported.

## TI zones within an edge fabric

A TI zone within an edge fabric is used to route traffic between a real device and a proxy device through a particular EX\_Port.

For example, in [Figure 45](#), you can set up a TI zone to ensure that traffic between Host 1 and the proxy target is routed through EX\_Port 9.

FIGURE 45 TI zone in an edge fabric

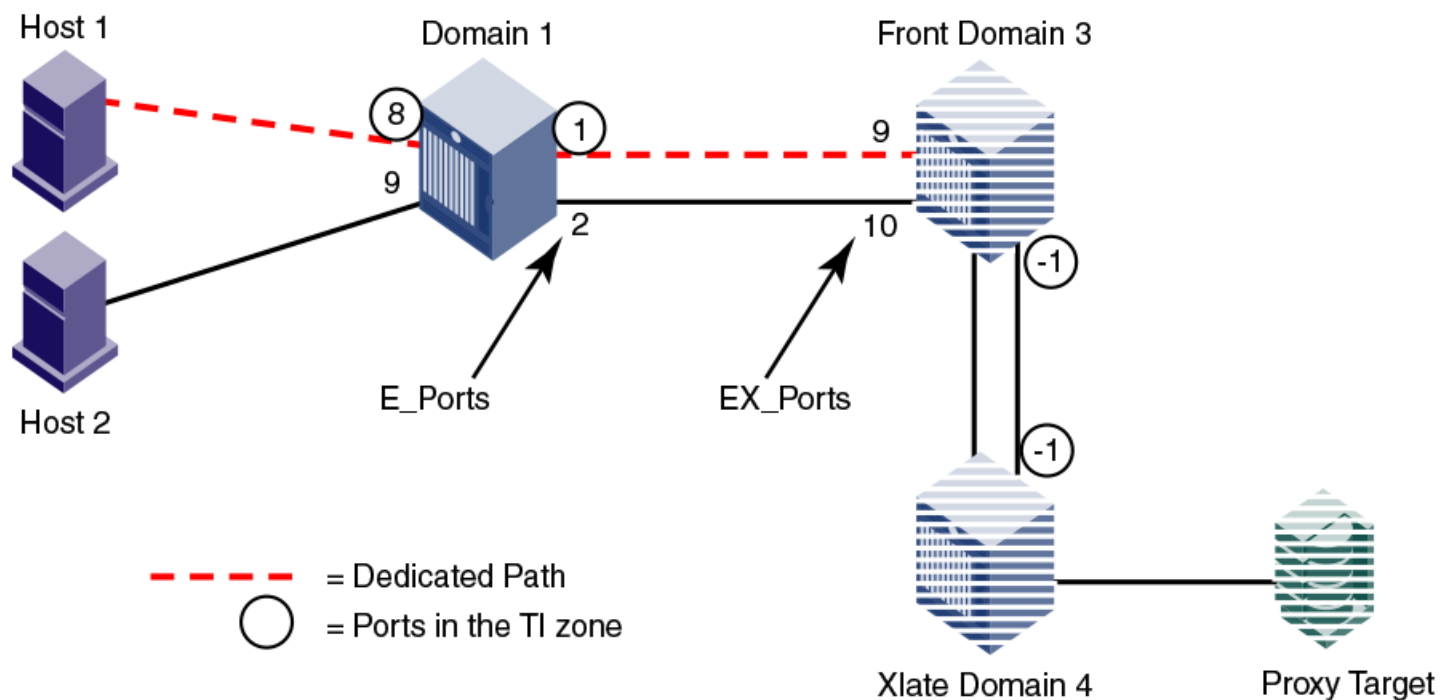

In the TI zone, when you designate E\_Ports between the front and xlate phantom switches, you must use -1 in place of the "1" in the D,I notation. Both the front and xlate domains must be included in the TI zone.

Using D,I notation, the members of the TI zone in Figure 45 are as follows:

- 1,8
- 1,1
- 3,-1 (E\_Port for the front phantom domain)
- 4,-1 (E\_Port for the xlate phantom domain)

#### NOTE

In this configuration the traffic between the front and xlate domains can go through any path between these two domains. The -1 does not identify any specific ISL. To guarantee a specific ISL, you need to set up a TI zone within the backbone fabric.

## TI zones within a backbone fabric

A TI zone within a backbone fabric is used to route traffic within the backbone fabric through a particular ISL.

For example, in Figure 46, a TI zone is set up in the backbone fabric to ensure that traffic between EX\_Ports "1,1" and "2,1" is routed through VE\_Ports "1,4" and "2,7".



FIGURE 46 TI zone in a backbone fabric

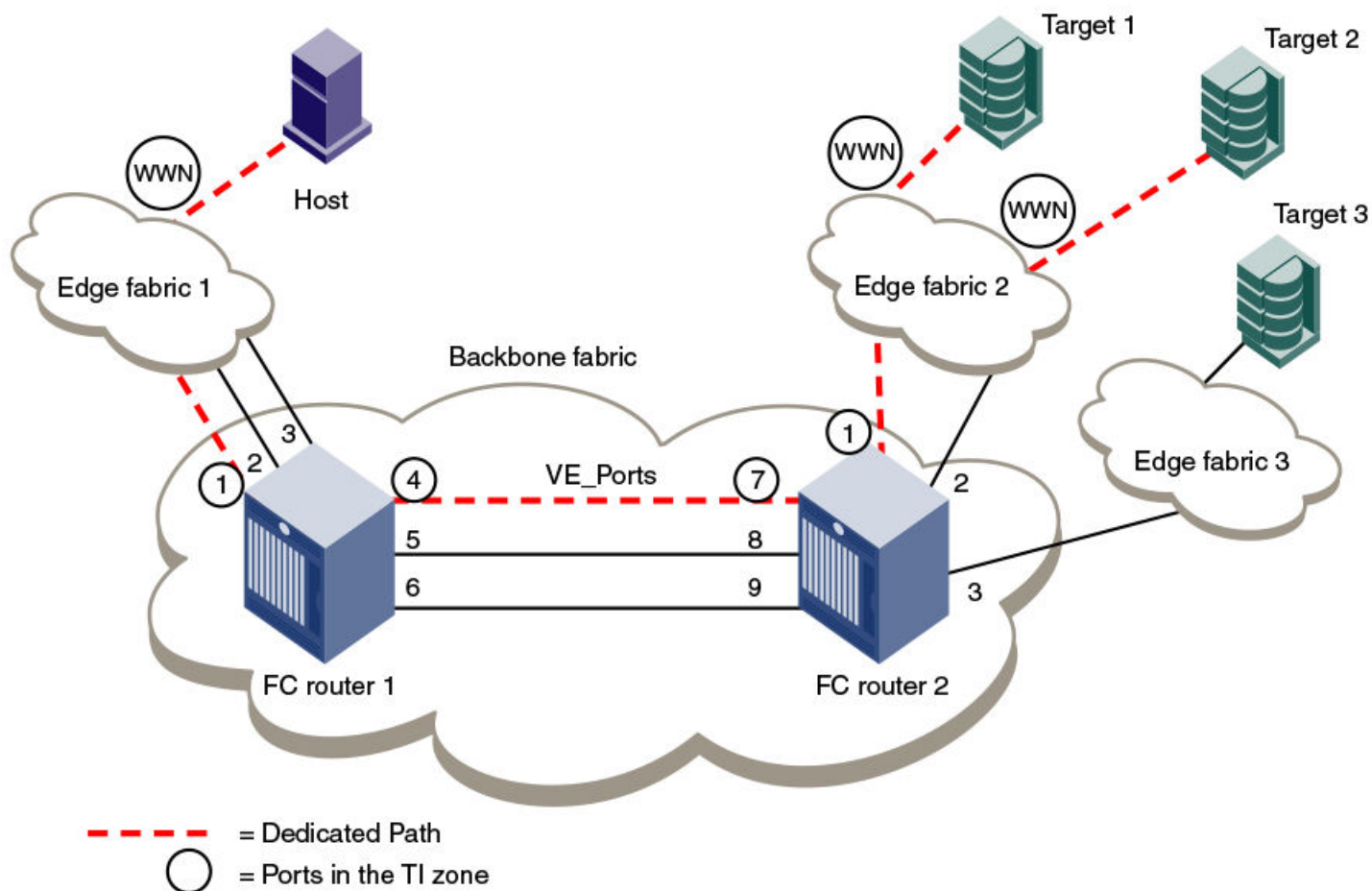

TI zones within the backbone fabric use the port WWN instead of D,I notation for devices that are to communicate across fabrics. (You can use the **portShow** command to obtain the port WWN.) Port WWNs should be used only in TI zones within a backbone fabric and should not be used in other TI zones.

Using D,I and port WWN notation, the members of the TI zone in [Figure 46](#) are as follows:

- 1,1 (EX\_Port for FC router 1)
- 1,4 (VE\_Port for FC router 1)
- 2,7 (VE\_Port for FC router 2)
- 2,1 (EX\_Port for FC router 2)
- 10:00:00:00:00:01:00:00 (Port WWN for the host)
- 10:00:00:00:00:02:00:00 (Port WWN for target 1)
- 10:00:00:00:00:03:00:00 (Port WWN for target 2)

## Limitations of TI zones over FC routers

Be aware of the following when configuring TI zones over FC routers:

- A TI zone defined within the backbone fabric does not guarantee that edge fabric traffic will arrive at a particular EX\_Port. You must set up a TI zone in the edge fabric to guarantee this.
- TI zones within the backbone fabric cannot contain more than one destination router port (DRP) per each fabric. This means you cannot define more than one EX\_Port to any one edge fabric unless they are part of a trunk.
- Only one egress E\_Port or VE\_Port connected to the next hop can be defined within TI zones. Only one ISL or trunk can be defined between two backbone switches. The E\_Port in the backbone fabric TI zone should be the least cost ISL.
- TI over FCR is supported only from edge fabric to edge fabric. Traffic isolation from backbone to edge is not supported.
- Non-TI data traffic is *not* restricted from going through the TI path in the backbone fabric.
- For TI over FCR, failover must be enabled in the TI zones in the edge fabrics and in the backbone fabric.
- TI over FCR is not supported with FC Fast Write.
- ETIZ over FCR is not supported.
- Configuring backbone TI zone with remote FC router EX\_Port is not supported if local chassis has the EX\_Port to source and destination edge fabric in the same chip/port group.
- *For the FX8-24 blades only:* If Virtual Fabrics is disabled, two or more shared area EX\_Ports connected to the same edge fabric should not be configured in different TI zones. This configuration is not supported.

## Fabric-Level Traffic Isolation in a backbone fabric

For Fibre Channel Routed (FCR) environments, you can use TI zoning if you want traffic isolation only at the fabric level and not at the device level.

For example, two fabrics within a MetaSAN need to communicate only with each other. There is no other traffic across the backbone that goes from either of these edge fabrics to any other edge fabric in the MetaSAN. In this case, all of the traffic entering the FCR backbone from one of these edge fabrics will go to the other edge fabric. If these two edge fabrics are connected to two different backbone switches (FC routers), then traffic between these fabrics can be isolated to a specified set of links within the backbone fabric using one of two methods:

- TI over FCR, which includes the PWWN of devices and maintains device level isolation
- TI zoning in the backbone, which provides fabric level isolation

If device-level isolation is needed from one edge fabric to another, then use TI over FCR using Port World Wide Names (PWWNs). However, if there is no need for device-level isolation, but a need for fabric-level isolation, then use Fabric-Level Traffic Isolation, described in this section.

TI over FCR is described in [Traffic Isolation Zoning over FC routers](#) on page 370.

If two edge fabrics are connected to two different backbone switches, then traffic between these fabrics can be isolated to a specified set of links within the backbone fabric using TI zoning in the backbone without including device PWWNs. This is called Fabric-Level Traffic Isolation, as shown in the following figure.

FIGURE 47 Fabric-level traffic isolation

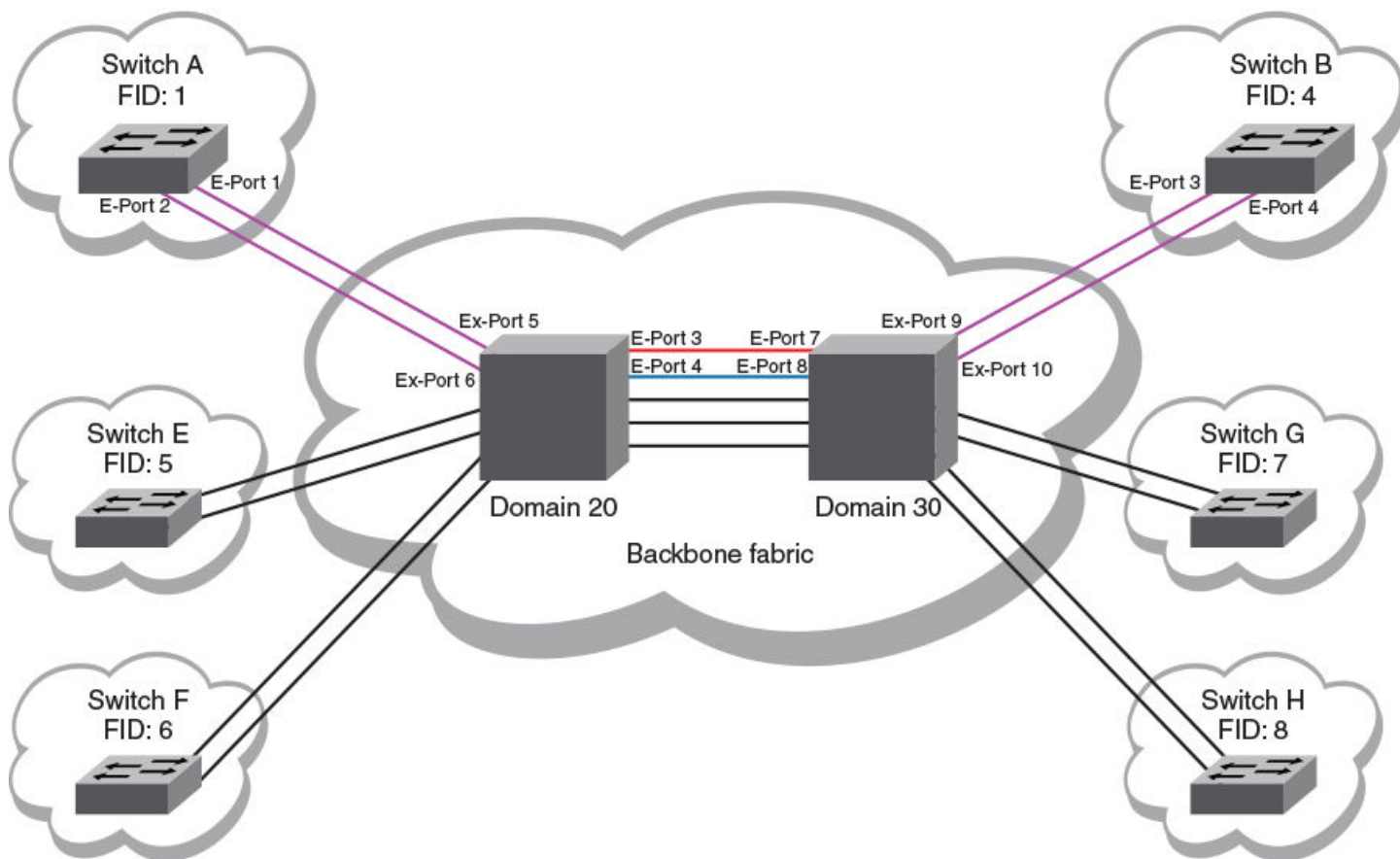

In the figure, there are two links between each edge fabric and the backbone fabric, and there are five links between the two FC routers in the backbone. Fabric ID 1 and Fabric ID 4 communicate only with each other. Two backbone ISLs are dedicated to traffic between FID1 and FID4. These dedicated ISLs are indicated in red and blue.

## Fabric-Level TI zones

Fabric-Level Traffic Isolation is accomplished through the use of TI zones. These zones define the dedicated set of paths between the two fabrics. These paths are to be restricted to just the traffic between the two fabrics.

Fabric-Level TI zones are defined in the backbone fabric, and include only EX\_Ports and E\_Ports in the backbone fabric. The TI zones do not include device PWWNs or ports in the edge fabrics.

The TI zone must include every port in the path from ingress EX\_Port to egress EX\_Port. The TI zone definitions must include all EX\_Ports connected to the two edge fabrics. Unless all possible ingress ports are included, some traffic will not be isolated to the desired paths.

Fabric-Level Traffic Isolation is not enforced on the egress EX\_Ports. Any available egress IFL can be used, regardless of whether it is in the Fabric-Level TI zone.

The following rules apply to creating Fabric-Level TI zones:

- Include all EX\_Ports connected to the two edge fabrics.

- Include E\_Ports for the path between the backbone switches.
- Do not include E\_Ports from the edge fabrics.
- Do not include device PWWNs.
- Ensure that failover is enabled.

There are two options for defining the Fabric-Level Traffic Isolation paths within TI zones. The option you select affects the failover behavior of the TI zones.

- Create a separate TI zone for each path
- Combine all of the paths in a single TI zone

## Failover behavior for Fabric-Level TI zones

Fabric-Level Traffic Isolation requires the TI zones in the backbone to have failover enabled. The failover behavior differs depending on how you create the TI zones.

If you create a separate TI zone for each path:

- If one of the TI zone paths fails, then traffic on that path is re-routed to a non-dedicated path.

For example, in [Figure 47](#) on page 375, if the BLUE path fails, then traffic associated with the BLUE path is re-routed to a black path.

If you combine all of the paths in a single TI zone:

- If one of the paths in the TI zone fails, then traffic on that path is re-routed to another path in the TI zone.

For example, in [Figure 47](#) on page 375, if the BLUE path fails, then traffic associated with the BLUE path is re-routed to the RED path.

Failover behavior for Fabric-Level TI zones is the same as for other TI zones, as described in [TI zone failover](#) on page 358.

## Creating a separate TI zone for each path

Brocade recommends that you create a separate TI zone for each path if you want TI traffic to failover to non-TI zone paths.

This example procedure creates two TI zones in the backbone fabric shown in [Figure 47](#) on page 375.

1. Create TI zones with failover enabled.

Each TI zone must include the ingress and egress EX\_Ports, as well as the E\_Ports between the two backbone switches. Do not include the edge fabric E\_Ports or device PWWNs.

```
switch:admin> zone --create -t ti TI_Zone_Red -p "20,5; 20,3; 30,7; 30,9"
switch:admin> zone --create -t ti TI_Zone_Blue -p "20,6; 20,4; 30,8; 30,10"
```

By default, a new TI zone is configured as "Activated" with failover enabled.

2. Display defined TI zones.

```
switch:admin> zone --show

Defined TI zone configuration:
TI Zone Name:   TI_Zone_Blue
Port List:      20,6; 20,4; 30,8; 30,10
Configured Status: Activated / Failover-Enabled
Enabled Status: Deactivated
TI Zone Name:   TI_Zone_Red
Port List:      20,5; 20,3; 30,7; 30,9
Configured Status: Activated / Failover-Enabled
Enabled Status: Deactivated
```

Be aware that although the configured status is "Activated", the enabled status is "Deactivated".

### 3. Activate TI zones.

```
switch:admin> cfgactvshow

Effective configuration:
cfg: <current effective configuration
>
...
switch:admin> cfgenable <current effective configuration
>
You are about to enable a new zoning configuration.
This action will replace the old zoning configuration with the
current configuration selected. If the update includes changes
to one or more traffic isolation zones, the update may result in
localized disruption to traffic on ports associated with
the traffic isolation zone changes
Do you want to enable 'TI_Config' configuration (yes, y, no, n): [no] y

zone config "name" is in effect
Updating flash ...
switch:admin>
Switch:admin> zone --show

Defined TI zone configuration:
TI Zone Name:   TI_Zone_Blue
Port List:     20,6; 20,4; 30,8; 30,10
Configured Status: Activated / Failover-Enabled
Enabled Status: Activated / Failover-Enabled
TI Zone Name:   TI_Zone_Red
Port List:     20,5; 20,3; 30,7; 30,9
Configured Status: Activated / Failover-Enabled
Enabled Status: Activated / Failover-Enabled
```

The enabled status now displays as "Activated".

## Creating a single TI zone for all paths

Brocade recommends that you create a single TI zone for all paths if you want TI traffic to failover to other paths in the TI zone.

### 1. Create a single TI zone with failover enabled.

The TI zone must include the ingress and egress EX\_Ports, as well as the E\_Ports between the two backbone switches. Do not include the edge fabric E\_Ports or device PWWNs.

```
switch:admin> zone --create -t ti TI_Zone_ALL -p "20,3; 20,4; 20,5; 20,6; 30,7; 30,8; 30,9 30,10"
```

By default, a new TI zone is configured as "Activated" with failover enabled.

### 2. Display defined TI zone.

```
switch:admin> zone --show

Defined TI zone configuration:
TI Zone Name:   TI_Zone_ALL
Port List:     20,3; 20,4 20,5; 20,6; 30,7; 30,8; 30,9; 30,10
Configured Status: Activated / Failover-Enabled
Enabled Status: Deactivated
```

Be aware that although the configured status is "Activated", the enabled status is "Deactivated".

### 3. Activate the TI zone.

```
switch:admin> cfgactvshow

Effective configuration:
```

```

cfg: <current effective configuration
>
...
switch:admin> cfgenable <current effective configuration
>
You are about to enable a new zoning configuration.
This action will replace the old zoning configuration with the
current configuration selected. If the update includes changes
to one or more traffic isolation zones, the update may result in
localized disruption to traffic on ports associated with
the traffic isolation zone changes
Do you want to enable 'TI_Config' configuration (yes, y, no, n): [no] y

zone config "name" is in effect
Updating flash ...
switch:admin>
Switch:admin> zone --show

Defined TI zone configuration:
TI Zone Name:   TI_Zone_ALL
Port List:     20,3; 20,4; 20,5; 20,6; 30,7; 30,8; 30,9; 30,10
Configured Status: Activated / Failover-Enabled
Enabled Status: Activated / Failover-Enabled

```

Then enabled status now displays as "Activated".

## Setting up TI zones over FCR (sample procedure)

The following example shows how to set up TI zones over FCR to provide a dedicated path shown in [Figure 48](#). In this example, three TI zones are created: one in each of the edge fabrics and one in the backbone fabric. The combination of these three TI zones creates a dedicated path for traffic between Host 1 in edge fabric 1 and Targets 1 and 2 in edge fabric 2.

Host 1 has port WWN 10:00:00:00:00:08:00:00

Target 1 has port WWN 10:00:00:00:00:02:00:00

Target 2 has port WWN 10:00:00:00:00:03:00:00

FIGURE 48 TI over FCR example

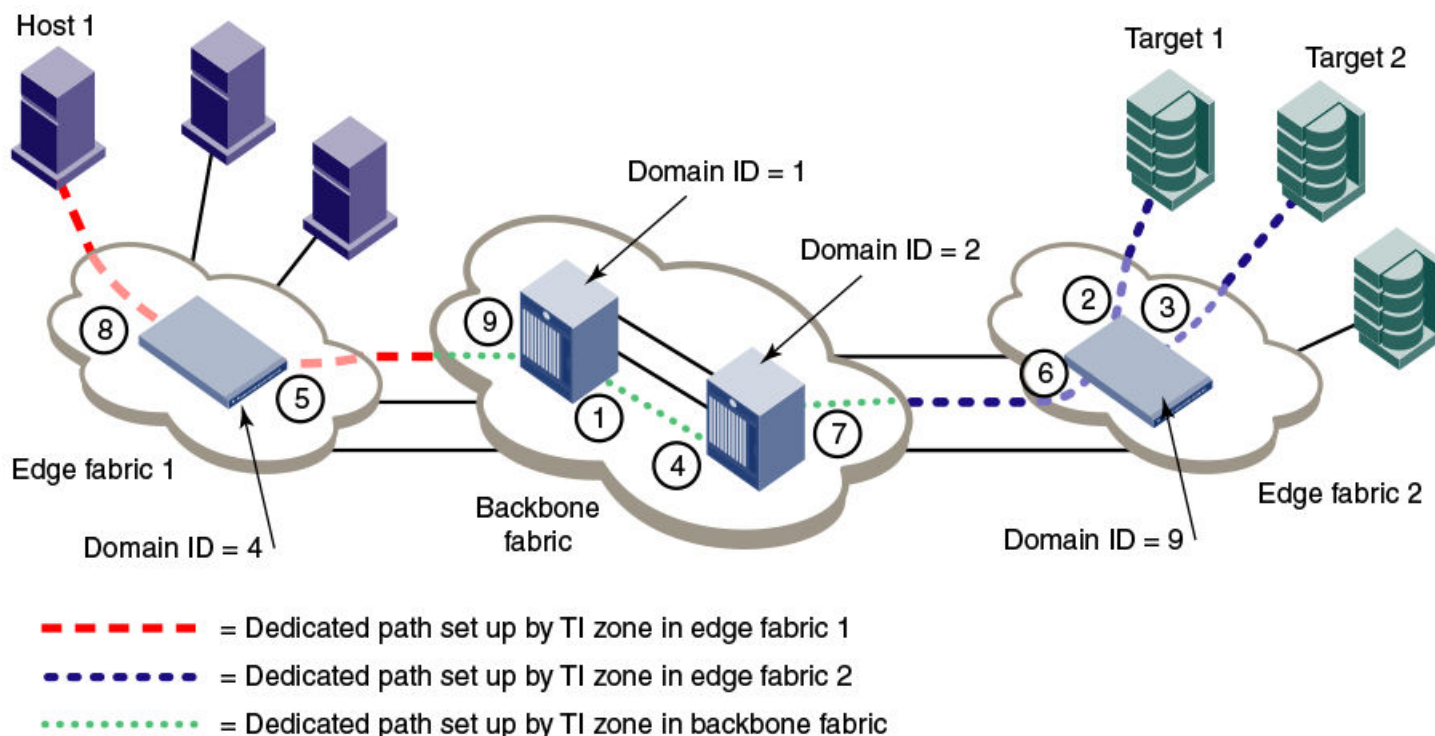

## NOTE

In the following procedure the three TI zones in the edge and backbone fabrics are all given the same name, TI\_Zone1. It is not required that the TI zones have the same name, but this is done to avoid confusion. If several dedicated paths are set up across the FCR, the TI zones for each path can have the same name.

1. In each edge fabric, set up an LSAN zone that includes Host 1, Target 1, and Target 2, so these devices can communicate with each other. See [Using FC-FC Routing to Connect Fabrics](#) on page 489 for information about creating LSAN zones.
2. Log in to the edge fabric 1 and set up the TI zone.
  - a) Enter the **fabricShow** command to display the switches in the fabric. From the output, you can determine the front and translate domains.

```
Elswitch:admin> fabricshow
```

Switch ID	Worldwide Name	Enet IP Addr	FC IP Addr	Name
1:	fffc01 50:00:51:e3:95:36:7e:04	0.0.0.0	0.0.0.0	"fcr_fd_1"
4:	fffc04 10:00:00:60:69:80:1d:bc	10.32.72.4	0.0.0.0	>"Elswitch"
6:	fffc06 50:00:51:e3:95:48:9f:a0	0.0.0.0	0.0.0.0	"fcr_xd_6_9"

The Fabric has 3 switches

- b) Enter the following commands to create and display a TI zone:

```
Elswitch:admin> zone --create -t ti TI_Zone1 -p "4,8; 4,5, 1,-1; 6,-1"
```

```
Elswitch:admin> zone --show
```

```
Defined TI zone configuration:
TI Zone Name: TI_Zone1
```

```
Port List:      4,8; 4,5; 1,-1; 6,-1
Status: Activated      Failover: Enabled
```

- c) Enter the following commands to reactivate your current effective configuration and enforce the TI zones.

```
E1switch:admin> cfgactvshow

Effective configuration:
cfg:   cfg_TI
zone:  lsan_t_i_TI_Zone1
      10:00:00:00:00:00:02:00:00
      10:00:00:00:00:00:03:00:00
      10:00:00:00:00:00:08:00:00
E1switch:admin> cfgenable cfg_TI

You are about to enable a new zoning configuration.
This action will replace the old zoning configuration with the
current configuration selected.
If the update includes changes to one or more traffic isolation zones, the update may result in
localized disruption to traffic on ports associated with the traffic isolation zone changes
Do you want to enable 'cfg_TI' configuration (yes, y, no, n): [no] y
zone config "cfg_TI" is in effect
Updating flash ...
```

3. Log in to the edge fabric 2 and set up the TI zone.

- a) Enter the **fabricShow** command to display the switches in the fabric. From the output, you can determine the front and translate domains.

```
E2switch:admin> fabricshow

Switch ID   Worldwide Name           Enet IP Addr   FC IP Addr   Name
-----
1: fffc01 50:00:51:e3:95:36:7e:09 0.0.0.0        0.0.0.0      "fcr_fd_1"
4: fffc04 50:00:51:e3:95:48:9f:a1 0.0.0.0        0.0.0.0      "fcr_xd_6_9"
9: fffc09 10:00:00:05:1e:40:f0:7d 10.32.72.9    0.0.0.0      >"E2switch"
The Fabric has 3 switches
```

- b) Enter the following commands to create and display a TI zone:

```
E2switch:admin> zone --create -t ti TI_Zone1 -p "9,2; 9,3; 9,6; 1,-1; 4,-1"

E2switch:admin> zone --show

Defined TI zone configuration:
TI Zone Name:   TI_Zone1
Port List:      9,2; 9,3; 9,6; 1,-1; 4,-1
Status: Activated      Failover: Enabled
```

- c) Enter the following commands to reactivate your current effective configuration and enforce the TI zones.

```
E2switch:admin> cfgactvshow

Effective configuration:
cfg:   cfg_TI
zone:  lsan_t_i_TI_Zone1
      10:00:00:00:00:00:02:00:00
      10:00:00:00:00:00:03:00:00
      10:00:00:00:00:00:08:00:00
E2switch:admin> cfgenable cfg_TI

You are about to enable a new zoning configuration.
This action will replace the old zoning configuration with the
current configuration selected.
If the update includes changes to one or more traffic isolation zones, the update may result in
localized disruption to traffic on ports associated with the traffic isolation zone changes
Do you want to enable 'cfg_TI' configuration (yes, y, no, n): [no] y
zone config "cfg_TI" is in effect
Updating flash ...
```



4. Log in to the backbone fabric and set up the TI zone.

```
FCR_Domain_1:admin> fabricshow
Switch ID   Worldwide Name           Enet IP Addr   FC IP Addr     Name
-----
1: fffc01 10:00:00:05:1e:52:3a:00 10.38.135.15   0.0.0.0        >"FCR_Domain_1"
2: fffc02 10:00:00:27:f8:f1:0b:40 10.38.135.19   0.0.0.0        "FCR_Domain_2"
```

The Fabric has 2 switches

The above Backbone domains are represented in "D.I" notation in TI zone configuration.

- a) Enter the following commands to create and display a TI zone:

```
FCR_Domain_1:admin> zone --create -t ti TI_Zone1 -p "1,9; 1,1; 2,4; 2,7;
10:00:00:00:00:08:00:00; 10:00:00:00:00:02:00:00; 10:00:00:00:00:03:00:00"
FCR_Domain_1:admin> zone --show
Defined TI zone configuration:
TI Zone Name: TI_Zone1
Port List: 1,9; 1,1; 2,4; 2,7; 10:00:00:00:00:08:00:00;
10:00:00:00:00:02:00:00; 10:00:00:00:00:03:00:00
Status: Activated Failover: Enabled
```

- b) Enter the following commands to reactivate your current effective configuration and enforce the TI zones.

```
FCR_Domain_1:admin> cfgactvshow
Effective configuration:
cfg: cfg_TI
zone: lsan_t_i_TI_Zone1
10:00:00:00:00:00:02:00:00
10:00:00:00:00:00:03:00:00
10:00:00:00:00:00:08:00:00
FCR_Domain_1:admin> cfgenable cfg_TI
You are about to enable a new zoning configuration.
This action will replace the old zoning configuration with the
current configuration selected.
If the update includes changes to one or more traffic isolation zones, the
update may result in localized disruption to traffic on ports associated
with the traffic isolation zone changes
Do you want to enable 'cfg_TI' configuration (yes, y, no, n): [no] y
zone config "cfg_TI" is in effect
Updating flash ...
```

## Virtual Fabrics considerations for Traffic Isolation Zoning

TI zones can be created in a logical fabric like in regular fabrics, with the following exceptions:

- The disable failover option is not supported in logical fabrics that use XISLs.
 

Although logical switches that use XISLs allow the creation of a TI zone with failover disabled, this is not a supported configuration. Base switches do not allow the creation of a TI zone with failover disabled.
- To create a TI zone for a logical fabric that uses XISLs, you must create two TI zones: one in the logical fabric and one in the base fabric. The combination of TI zones in the base fabric and logical fabric sets the path through the base fabric for logical switches.

The TI zone in the logical fabric includes the extended XISL (XISL) port numbers, as well as the F\_Ports and ISLs in the logical fabric.

Because base fabrics do not contain end devices, they normally do not have an effective zone configuration. To activate a TI zone in a base fabric, you must create a "dummy" configuration. TI zones are otherwise created in the same manner as a regular fabric with the exception that TI zone failover cannot be disabled with TI zones in the base fabric.

The TI zone in the base fabric reserves XISLs for a particular logical fabric. The base fabric TI zone should also include ISLs that belong to logical switches participating in the logical fabric.

Figure 49 shows an initiator and target in a logical fabric (FID1). The dotted line indicates a dedicated path between initiator and target. The dedicated path passes through the base fabric over an XISL. (The figure shows only physical ISLs, not logical ISLs.) To create the TI zones for this dedicated path, you must create a TI zone in the logical fabric (FID 1) and one in the base fabric.

FIGURE 49 Dedicated path with Virtual Fabrics

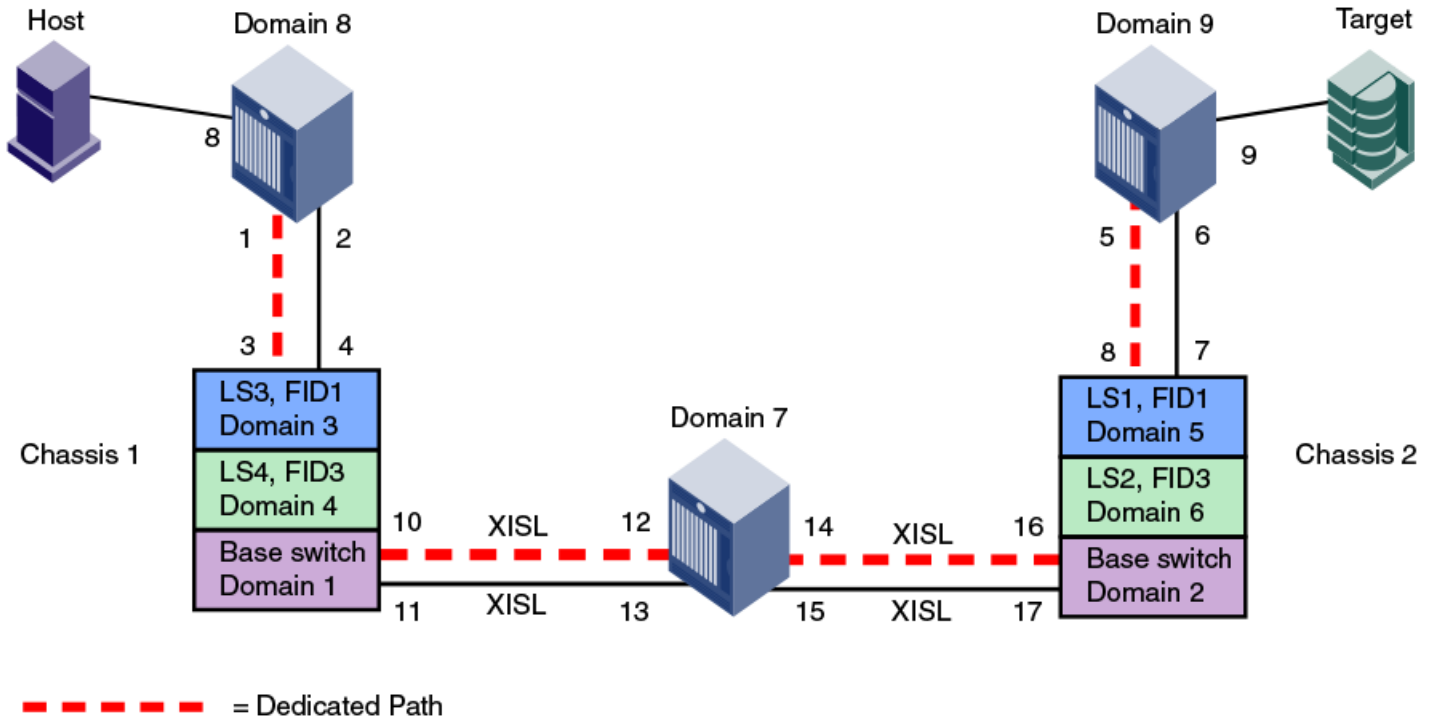
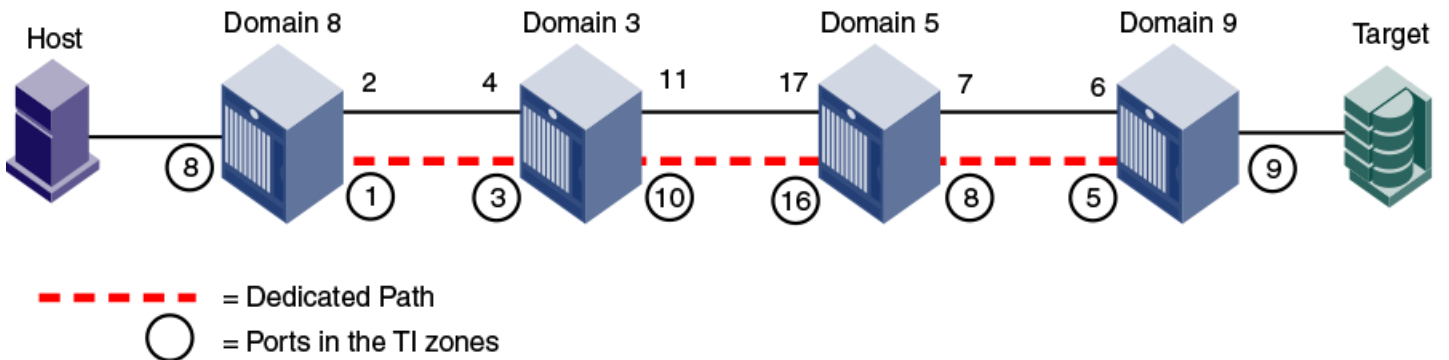

Figure 50 shows a logical representation of FID1 in Figure 49. To create the dedicated path, you must create and activate a TI zone in FID1 that includes the circled ports shown in Figure 50.

FIGURE 50 Creating a TI zone in a logical fabric



You must also create and activate a TI zone in the base fabric to reserve the XISLs for the dedicated path. In [Figure 51](#), the XISLs highlighted (by a dotted line) in the base fabric can be reserved for FID1 by defining and activating a base fabric TI zone that consists of ports 10, 12, 14, and 16. You must also include ports 3 and 8, because they belong to logical switches participating in the logical fabric. For the TI zone, it is as though ports 3 and 8 belong to Domains 1 and 2 respectively.

FIGURE 51 Creating a TI zone in a base fabric

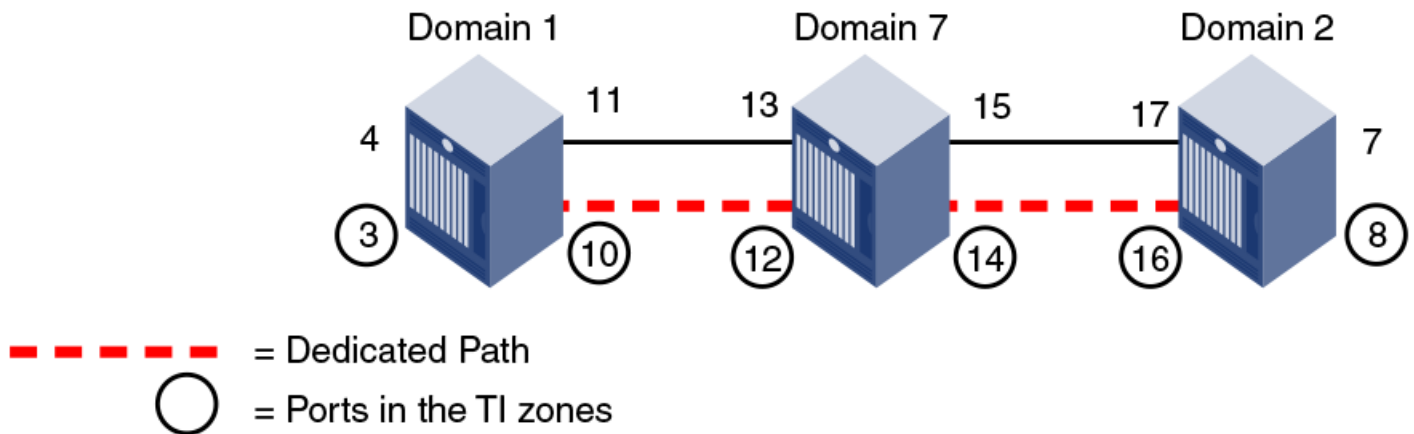

Using D,I notation, the port numbers for the TI zones in the logical fabric and base fabric are as follows:

Port members for the TI zone in logical fabric	Port members for the TI zone in base fabric
8,8 F_Port	1,3 E_Port for ISL in logical switch
8,1 E_Port	1,10 E_Port for XISL
3,3 E_Port	7,12 E_Port for XISL
3,10 E_Port	7,14 E_Port for XISL
5,16 E_Port	2,16 E_Port for XISL
5,8 E_Port	2,8 E_Port for ISL in logical switch
9,5 E_Port	
9,9 F_Port	

Notice that the base fabric zone contains a reference to port 1,3 even though the base switch with domain 1 does not have a port 3 in the switch. This number refers to the port in the *chassis* with port index 3, which actually belongs to LS3 in FID 1.

## Traffic Isolation Zoning over FC routers with Virtual Fabrics

This section describes how you can set up TI zones over FC routers in logical fabrics. [Figure 52](#) shows two physical chassis configured into logical switches. The initiator in FID 1 communicates with the target in FID 3 over the EX\_Ports in the base switches.

FIGURE 52 Example configuration for TI zones over FC routers in logical fabrics

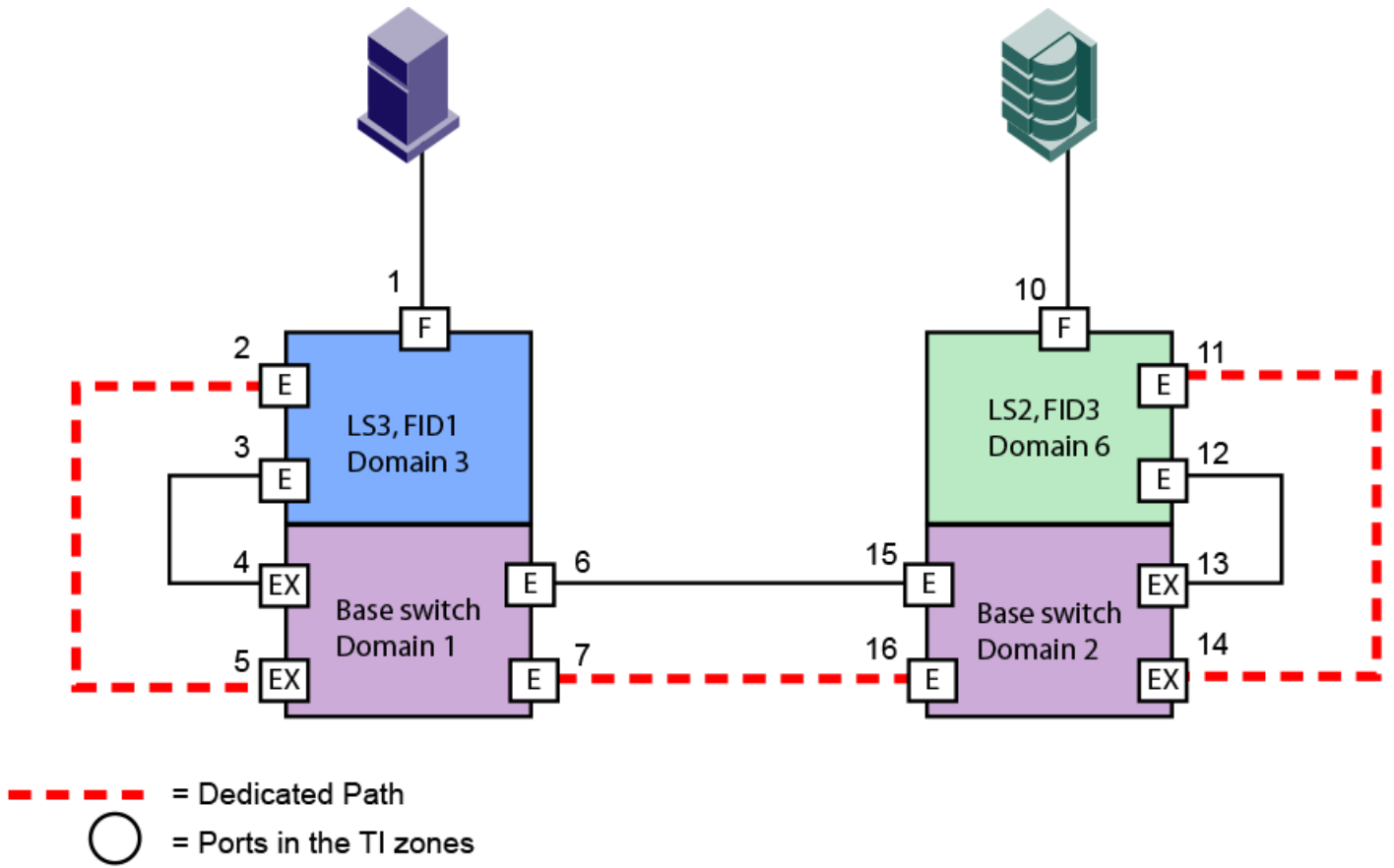
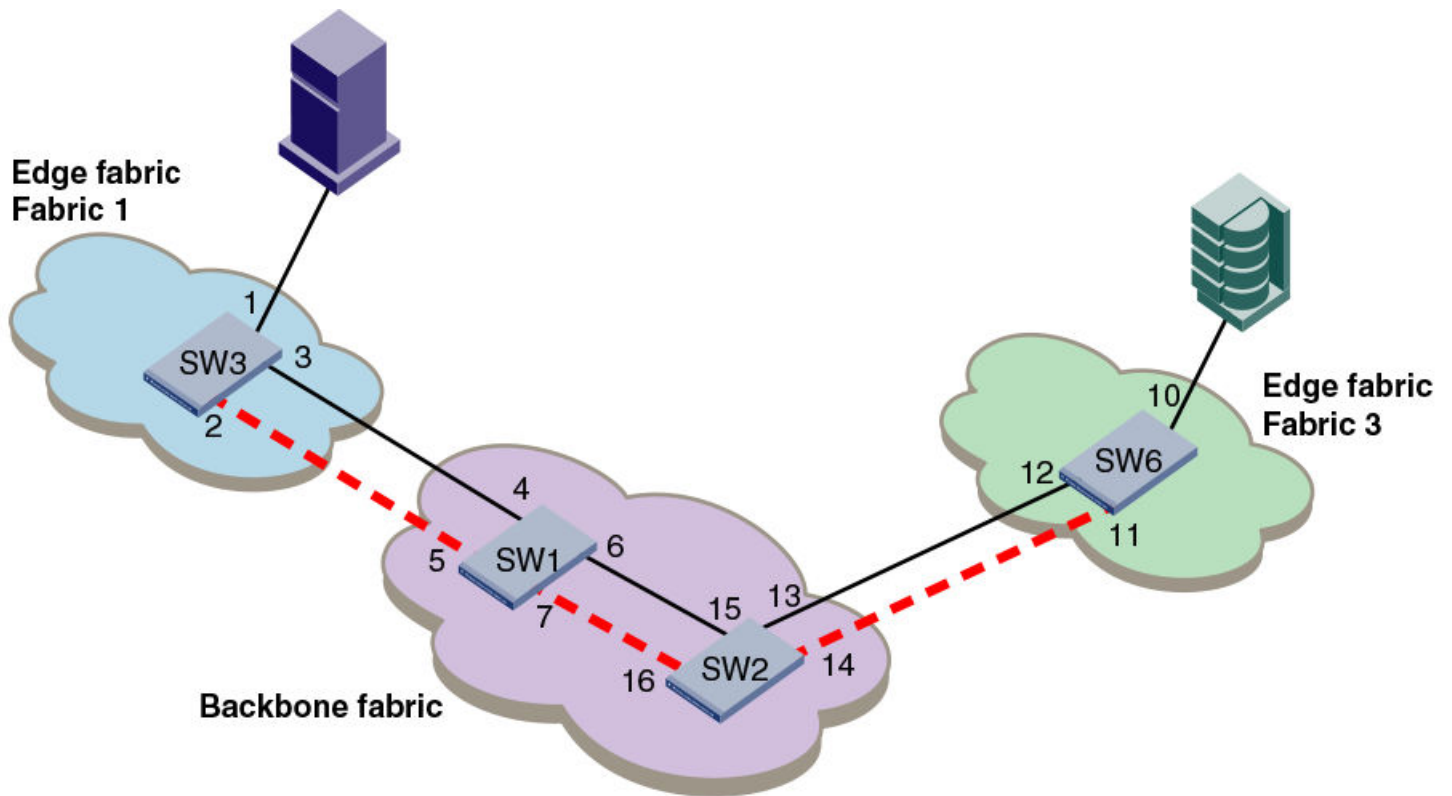

Figure 53 shows a logical representation of the configuration in Figure 52. This SAN is similar to that shown in Figure 44 on page 371 and you would set up the TI zones in the same way as described in Traffic Isolation Zoning over FC routers on page 370.

FIGURE 53 Logical representation of TI zones over FC routers in logical fabrics



## Troubleshooting TI zone routing problems

Use the following procedure to generate a report of existing and potential problems with TI zones. The report displays an error type.

- "ERROR" indicates a problem currently exists in the fabric.
- "WARNING" indicates that there is not currently a problem, given the current set of online devices and reachable domains, but given the activated TI zone configuration, parallel exclusive paths between a shared device and a remote domain have been detected, which might cause a problem for devices that join the fabric later.

1. Connect to the switch and log in using an account with admin permissions.
2. Enter the **zone --showTIerrors** command.

```
zone --showTIerrors
```

Here is an example report that would be generated for the illegal configuration shown in [Figure 41](#) on page 363.

```
switch:admin> zone --showTIerrors

My Domain: 3
Error type:          ERROR
Affected Remote Domain: 1
Affected Local Port: 8
Affected TI Zones:   etiz1, etiz2
Affected Remote Ports: 1, 2, 3, 4
```

## Traffic Isolation Zone violation handling for trunk ports

For any trunk group, all the members of the group need to belong to the TI zone to prevent routing issues resulting from changes in the members of the trunk group. This applies to any E\_Port or F\_Port trunk groups that are included in TI zones using failover disabled mode.

Fabric OS posts a RASlog message (ZONE-1061) if any of the ports part of a trunk group is not added to the TI zone with failover disabled. Also, a CLI (**zone --showTItrunkerrors**) is provided to check if all ports per switch in a TI zone are proper. This will help you identify missing trunk members and take corrective actions.

RASlog message when any port in a trunk group is not in the TI zone

```
SW82:FID128:admin> zone
[ZONE-1061], 620/181, FID 128, WARNING, sw0, Some trunk members are missing from failover disabled active
TI zones.
```

The CLI essentially displays the details of the trunk members present in the TI zone and those not present in the TI zone. These details are displayed per TI Zone basis.

RASlog message when --showTItrunkerrors is added to zone command

```
switch:admin> zone --showTItrunkerrors

TI Zone Name: brackets
E-Port Trunks
Trunk members in TI zone: 16 18
Trunk members not in TI zone: 17
F-Port Trunks
Trunk members in TI zone: 4 5
Trunk members not in TI zone: 6
TI Zone Name: loop
E-Port Trunks
Trunk members in TI zone: 0
Trunk members not in TI zone: 1
TI Zone Name: operand
E-Port Trunks
Trunk members in TI zone: 8
Trunk members not in TI zone: 9 10
E-Port Trunks
Trunk members in TI zone: 16
Trunk members not in TI zone: 17 18
```

# Optimizing Fabric Behavior

---

• <a href="#">Adaptive Networking overview</a> .....	387
• <a href="#">Ingress Rate Limiting</a> .....	387
• <a href="#">QoS</a> .....	388
• <a href="#">CS_CTL-based frame prioritization</a> .....	398

## Adaptive Networking overview

Adaptive Networking is a suite of tools and capabilities that enable you to ensure optimized behavior in the SAN. Under the worst congestion conditions, Adaptive Networking can maximize the fabric behavior and provide necessary bandwidth for high-priority, mission-critical applications and connections.

The Adaptive Networking suite includes the following features:

- **Traffic Isolation Zoning**

Traffic Isolation Zoning (TI zoning) allows you to control the flow of interswitch traffic by creating a dedicated path for traffic flowing from a specific set of source ports (F\_Ports). Traffic Isolation Zoning does not require a license. Refer to [Traffic Isolation Zoning](#) on page 357 for more information about this feature.

- **Quality of Service (QoS)**

QoS allows you to categorize the traffic flow between a host and target as having a high, medium, or low priority. QoS does not require a license. Refer to [QoS](#) on page 388 for more information about this feature.

You can use the Adaptive Networking features together to optimize the performance of your fabric. For example, you can use the features in the following ways:

- You can use Top Talkers to identify the SID/DID pairs that consume the most bandwidth and can then configure them with certain QoS attributes so they get proper priority.
- If the bottleneck detection feature detects a latency bottleneck, you can use TI zones or QoS to isolate latency device traffic from high-priority application traffic.
- If the bottleneck detection feature detects ISL congestion, you can use Ingress Rate Limiting to slow down low-priority application traffic if it is contributing to the congestion.

## Ingress Rate Limiting

Ingress Rate Limiting restricts the speed of traffic from a particular device to the switch port.

Use Ingress Rate Limiting for the following situations:

**NOTE**

Gen-6 platforms do not support ingress rate limiting.

- To reduce existing congestion in the network or proactively avoid congestion.
- To enable you to offer flexible bandwidth-limit services based on requirements.
- To enable more important devices to use the network bandwidth during specific services, such as network backup.

To limit the traffic, you set the maximum speed at which the traffic can flow through a particular F\_Port or FL\_Port. For example, if you set the rate limit at 4 Gbps, then traffic from a particular device is limited to a maximum of 4 Gbps.

Ingress Rate Limiting enforcement is needed only if the port can run at a speed higher than the rate limit. For example, if the rate limit is 4 Gbps and the port is only a 2-Gbps port, then Ingress Rate Limiting is not enforced.

The Ingress Rate Limiting configuration is persistent across reboots.

You should keep in mind the following considerations about Ingress Rate Limiting:

- Ingress Rate Limiting is applicable only to F\_Ports and FL\_Ports.
- QoS takes precedence over Ingress Rate Limiting.
- Ingress Rate Limiting is not enforced on trunked ports.
- Ingress Rate Limiting can also be used on simulation ports (SIM ports).

## Virtual Fabrics considerations

If Virtual Fabrics is enabled and if a port is configured to have a certain rate limit value, you must first disable the rate limit on the port before moving it to a different logical switch. Ports cannot be moved when they have rate limit configured on them.

## Limiting traffic from a particular device

1. Connect to the switch and log in using an account with admin permissions.
2. Enter the **portCfgQos --setratelimit** command.

```
portcfgqos --setratelimit [slot/]port ratelimit
```

Example of setting the rate limit on slot 3, port 9 to 4000 Mbps

```
portcfgqos --setratelimit 3/9 4000
```

## Disabling Ingress Rate Limiting

1. Connect to the switch and log in using an account with admin permissions.
2. Enter the **portCfgQos --resetratelimit** command.

```
portcfgqos --resetratelimit [slot/]port
```

Example of disabling Ingress Rate Limiting on slot 3, port 9

```
portcfgqos --resetratelimit 3/9
```

## QoS

Quality of Service (QoS) allows you to categorize the traffic flow between a host and a target as having a high, medium, or low priority.

Fabric OS supports two types of prioritization:

- Class-Specific Control (CS\_CTL)-based frame prioritization

Each frame between a host and a target is assigned a specific priority, depending on the value of the CS\_CTL field in the frame header.

- QoS zone-based traffic prioritization

All traffic between a host and a target is assigned a specific priority, depending on the name you define for the QoS zone.



CS\_CTL-based frame prioritization and QoS zone-based traffic prioritization are mutually exclusive. If you enable CS\_CTL-based frame prioritization on F\_Ports or FL\_Ports, then QoS zone-based traffic prioritization cannot be used between any devices connected to the F\_Ports or FL\_Ports.

CS\_CTL-based frame prioritization takes precedence over QoS zone-based traffic prioritization. If you enable CS\_CTL-based frame prioritization on F\_Ports or FL\_Ports that are defined in a QoS zone, CS\_CTL-based frame prioritization takes precedence over the QoS zones.

The following table shows a basic comparison between CS-CTL-based frame prioritization and QoS zone-based traffic prioritization. Refer to [CS\\_CTL-based frame prioritization](#) on page 398 and QoS zone-based traffic prioritization for detailed information about each type of prioritization scheme.

**TABLE 75** Comparison between CS\_CTL-based and QoS zone-based prioritization

CS_CTL-based frame prioritization	QoS zone-based traffic prioritization
Must be manually enabled.	Automatically enabled.
No zones are required.	Requires you to create QoS zones.
Enabled on F_Ports or FL_Ports.	Enabled on E_Ports.
Takes precedence over QoS zone-based traffic prioritization.	Is overridden by CS_CTL-based frame prioritization.
Priority is defined by CS-CTL field in frame header.	Priority is defined by name of QoS zone.
Prioritization is on a frame-basis.	Prioritization is on a flow-basis.
Setup steps: <ul style="list-style-type: none"> <li>• Enable CS_CTL mode on F_Ports or FL_Ports.</li> <li>• Ensure that the CS_CTL mode-enabled host and storage are zoned together.</li> </ul>	Setup steps: <ul style="list-style-type: none"> <li>• Create QoS zones with host/target members.</li> <li>• Add the QoS zones to the zone configuration.</li> <li>• Save and then enable the zone configuration.</li> <li>• Enable QoS on E_Ports.</li> </ul>

## License requirements for QoS

Starting in Fabric OS 7.2.0, QoS does not require the Adaptive Networking license to be explicitly installed. This license is automatically enabled for new switches and for existing switches that are upgraded to Fabric OS 7.2.0 or later.

If you upgrade to Fabric OS 7.2.0 and you did not previously have an Adaptive Networking license, then all ports that had QoS mode set to AE (automatically enabled) and were not using the QoS feature are automatically set to OFF after the upgrade.

## QoS on E\_Ports

In addition to configuring the hosts and targets in a zone, you must also enable QoS on individual E\_Ports that might carry traffic between the host and target pairs. Path selection between the "host,target" pairs is governed by FSPF rules and is not affected by QoS priorities. For example, in the following figure, QoS should be enabled on the encircled E\_Ports.

### NOTE

By default, QoS is enabled on 8-Gbps or higher ports. QoS is disabled by default on all long-distance ports.

FIGURE 54 QoS with E\_Ports enabled

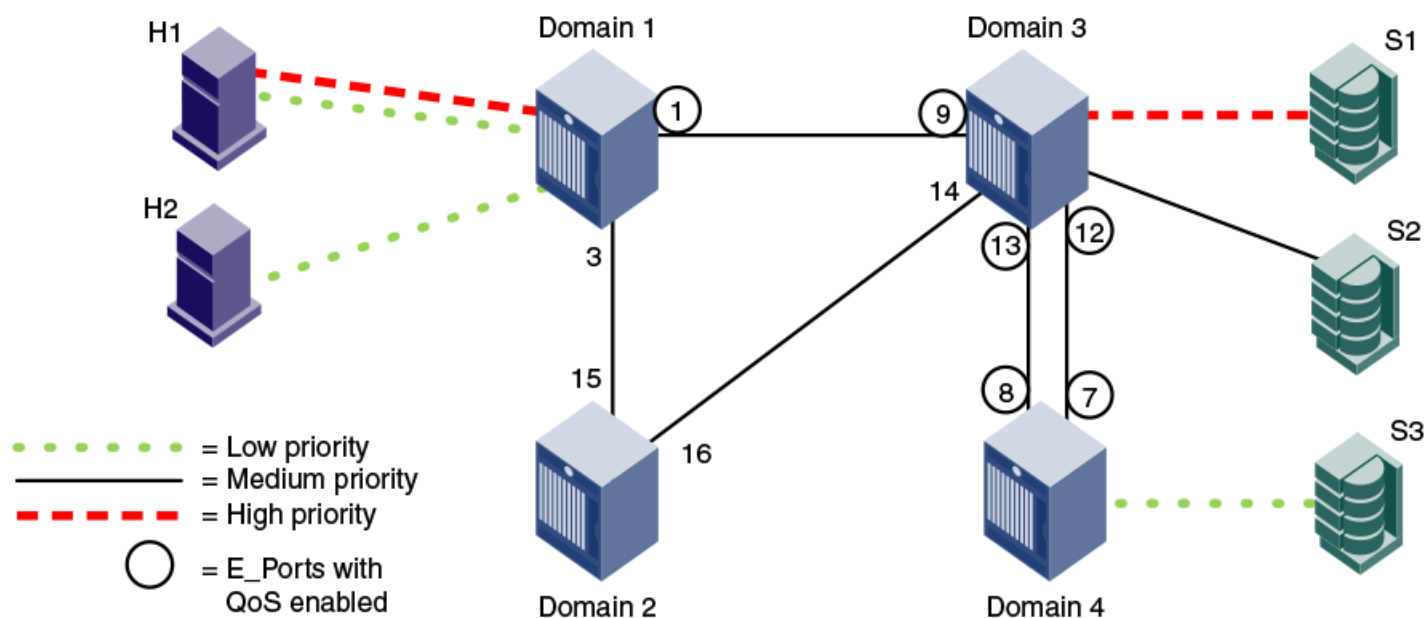

You must enable QoS on the E\_Ports on both ISLs between domain 3 and domain 4, because either path might be selected to carry the traffic.

You do *not* need to enable QoS on the E\_Ports on the ISLs between domain 1 and domain 2 and between domain 2 and domain 3, because these are not the shortest paths between the hosts and the targets. However, if the ISL between domain 1 and domain 3 is broken, then the path through domain 2 would be used.

To guarantee traffic priority, you should enable QoS on all possible E\_Ports. Alternatively, you could use a T1 zone to limit the E\_Ports that carry the traffic between a "host,target" pair and enable QoS on only those E\_Ports.

If QoS is not enabled on an E\_Port, the traffic prioritization stops at that point. For example, in the above figure if you disabled QoS on E\_Ports "3,12" and "3,13," then the traffic from H1 and H2 to S3 would be low priority from the hosts to domain 3, but would change to the default (medium) priority from domain 3 to the target S3.

## QoS over FC routers

QoS over FC routers uses QoS traffic prioritization between devices in edge fabrics over an FC router. Refer to [Using FC-FC Routing to Connect Fabrics](#) on page 489 for information about FC routers, phantom switches, and the FC-FC Routing Service.

To establish QoS over FC routers, you must perform the following tasks:

- Define QoS zones in each edge fabric.
- Define LSAN zones in each edge fabric.
- Enable QoS on the E\_Ports in each edge fabric.
- Enable QoS on the EX\_Ports in the backbone fabric.

Refer to [Setting QoS zone-based traffic prioritization over FC routers](#) on page 396 for detailed instructions.

The following are requirements for establishing QoS over FC routers:

- QoS over FC routers is supported in Brocade native mode only. It is not supported in interopmode 2 or interopmode 3.

- QoS over FC routers is supported for the following configurations:
  - Edge-to-edge fabric configuration: Supported on all platforms.
  - Backbone-to-edge fabric configuration: Supported on 16-Gbps (Gen 5) and 32-Gbps (Gen 6) platforms only (Brocade 6505, 6510, 6520, G620, M6505, 6547, 6548, Brocade DCX 8510 Backbones and X6 Directors), and only if no other platforms are used. For all other platforms, you cannot prioritize the flow between a device in an edge fabric and a device in the backbone fabric.
- QoS over FC routers is supported only if Virtual Fabrics is disabled in the backbone fabric. QoS over FC routers cannot be enabled if Virtual Fabrics is also enabled in the backbone fabric.
- The port WWN of the host or target and the port WWN of the proxy device must be in both an LSAN zone and a QoS zone.
- QoS over FC routers is supported on both EX\_Ports and VEX\_Ports.
- The EX\_Ports (or VEX\_Ports) in the path between the QoS devices must be on switches running Fabric OS v6.3.0 or later.
- QoS zones must use WWN notation only; D,I notation is not supported for QoS over FCRs.

## vTap and QoS High Priority Zoning Compatibility mode

The vTap analytics feature utilizes VC 14 for remote flow mirroring, and requires that this VC be reserved exclusively for mirrored traffic in order to ensure accurate results. When vTap is enabled, QoS high priority zoning ("QoSH/QoSH5") must operate in a manner that avoids assigning flows to VC 14. You can control this behavior by a configuration setting at each relevant switch in the fabric. If you require vTap and QoS high priority zoning, you must enable vTap/QoSH compatibility on the switches having QoS high devices and/or the switches where vTap needs to be configured. You can use the **configureChassis** command to enable the vTap and QoS High Priority Zone Compatibility Mode.

```
sw:admin> configurechassis

Configure...

cfgload attributes (yes, y, no, n): [no]
Custom attributes (yes, y, no, n): [no]
system attributes (yes, y, no, n): [no]
fos attributes (yes, y, no, n): [no] y

Reboot needed to effect new CCTL Mode
CCTL QoS Mode (0 = default; 1 = auto mode): (0..1) [0]
Chassis SDDQ Limit: (0..32) [10]
vTap and QoS High Priority Zone Compatibility Mode (on, off): [off]
```

If vTap/QoSH compatibility is enabled and the vTap features (i.e., remote flow mirroring) are also active on the local switch, then vTap/QoSH compatibility cannot be disabled. vTap features have to be deactivated on the local switch prior to disabling vTap/QoSH compatibility.

By default, "vTap and QoS High Priority Zone Compatibility Mode" is disabled. When disabled, the switch assigns QoS high priority zoning VCs in the usual manner.

### NOTE

The chassis must be disabled in order to enable the new compatibility mode, but only when the effective zoning configuration has QoSH (default VC assignment) and/or QoSH5 zones.

The **configureChassis** command can be issued from any logical switch partition/context, but affects a chassis-wide scope regardless of switch context.

## QoSH5 zones

QoSH/QoSH5 zones created from non-vTap/QoSH compatible switches, can be pushed to CM mode enabled switches as part of zone update. QoSH/QoSH5 zones added to the effective zoning configuration via a **configDownload** are permitted when vTap/QoSH

compatibility is enabled. However, creation of new QoS H5 zones using the **zoneCreate** command, Webtools, or BNA version 14.0.1 or higher are not allowed when vTap/QoS H compatibility is enabled. This enforcement is only applied on and for the local switch. For example, if a QoS H5 zone create, rename, or update command is run in a switch that is *not* configured for vTap/QoS H compatibility, the zone update is *accepted* on those switches where vTap/QoS H compatibility is enabled.

#### NOTE

The presence or absence of QoS H5 zones does not have any effect on fabric build, regardless of vTap and QoS H compatibility settings.

The **zoneCreate** command does not allow creation of QoS H5 zones when vTap and QoS H compatibility is enabled and the following message is displayed.

```
error: Operation is not allowed for QOSH5 zone "<zone name>" when vTap and QOS High Priority Zoning
Compatibility Mode is enabled
```

The **zoneRename** command does not allow the renaming of a given zone such that it becomes a QoS H5 zone when vTap/QoS H compatibility is enabled and the following message is displayed.

```
error: Operation is not allowed for QOSH5 zone "<zone name>" when vTap and QOS High Priority Zoning
Compatibility Mode is enabled.
```

Activation of vTap remote follow mirroring is prevented unless vTap and QoS H compatibility is enabled.

```
sw:admin>flow --activate sys_analytics_vtap
Enable vTap and QoS High Priority Zone Compatibility mode to activate vTap flow. Please use the
configureChassis command to enable this compatibility mode.
```

A best practice to avoid having to disable the chassis, you can perform the following steps:

1. Temporarily enable a zoning configuration that does not have any QoS high priority zones
2. Enable vTap/QoS H compatibility via **configureChassis** on all switches in the fabric
3. Re-enable a zoning configuration having the desired QoS high priority zones, with the recommendation to avoid QoS H5 zones with the new configuration

#### NOTE

To ensure a non-disruptive Brocade Analytics Monitoring Platform attachment to a fabric, Brocade recommends that you enable QoS H and vTap+QoS H compatibility mode on all switches in the fabric. In addition, you must connect any devices requiring QoS H or QoS H5 services only through switches running versions of Fabric OS that both support this compatibility mode and have it enabled.

## Virtual Fabrics considerations for QoS zone-based traffic prioritization

You can prioritize flows between devices in a logical fabric. The priority is retained for traffic going across ISLs and through the base fabric XISLs.

For example, the following figure shows a logical fabric that includes H1 and S1. To set the traffic between H1 and S1 to high priority, create a QoS zone in the logical fabric with H1 and S1 as members. Then enable QoS on all of the E\_Ports shown circled in the figure, including all of the E\_Ports in the XISLs (ports 10, 11, 12, 13, 14, 15, 16, and 17).

FIGURE 55 Traffic prioritization in a logical fabric

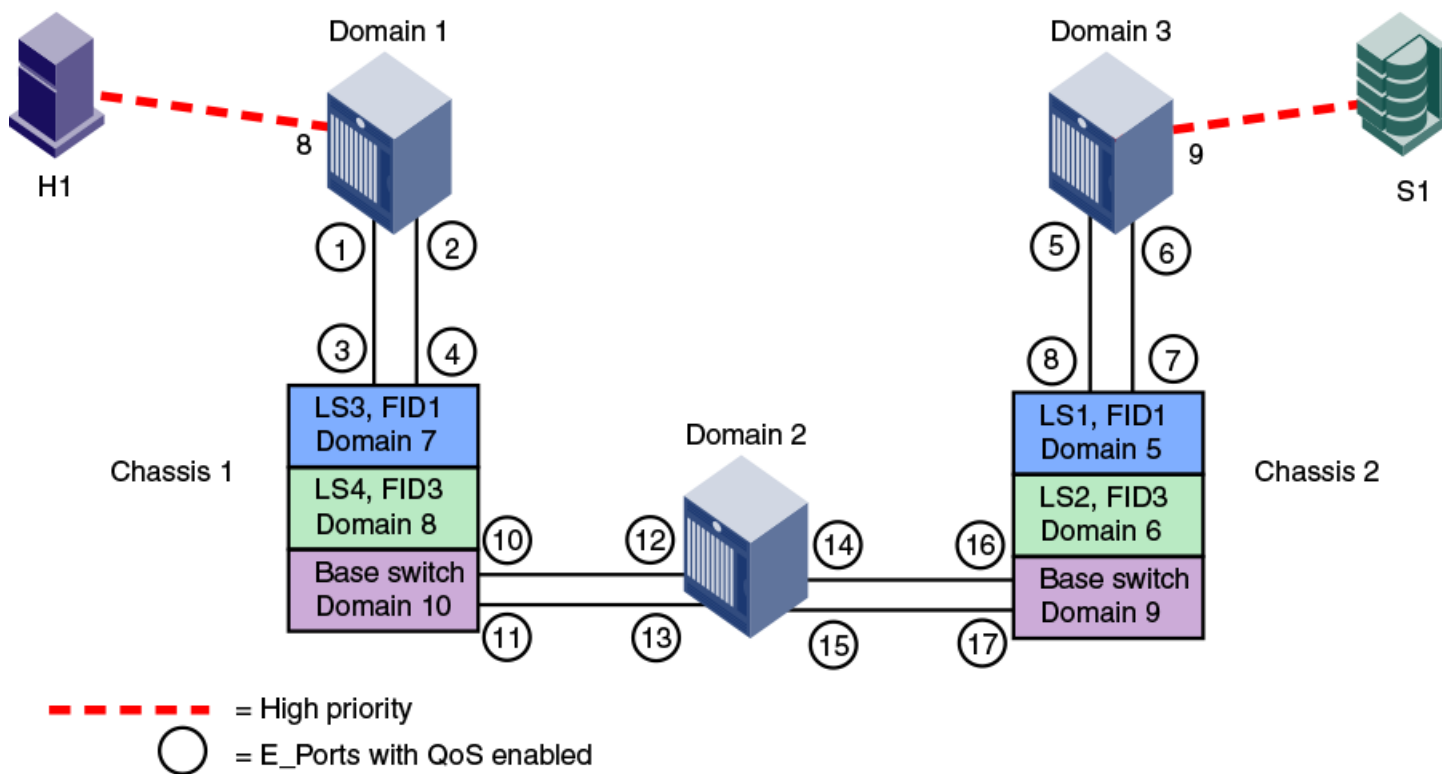

## Traffic prioritization based on QoS zones

Quality of service (QoS) zones are user-defined zones that allow you to manage the traffic priority between specified host-target pairs. You assign these pairs high, medium, or low quality of service (QoS)-level priority by configuring a QoS zone for that level, and then identifying those pairs as members of the appropriate zone. A host-target pair can only belong to one QoS zone. By default, traffic in non-QoS zones is assigned medium priority.

QoS zones can contain WWN members (WWNN or WWPNN) or *domain.index*(D,I) members. If you use D,I notation in your QoS zones, refer to [Limitations and restrictions for QoS zone-based traffic prioritization](#) on page 397 for some considerations.

A QoS zone has a special name format to differentiate it from a regular zone, which determines the priority of the traffic flow. The format of the QoS zone name is as follows, and *id* is a flow identifier that designates a specific virtual circuit (VC) for the traffic flow and *xxxxx* is the user-defined portion of the name. The switch automatically sets the priority for the "host,target" pairs specified in the zones according to the priority level (H, M, or L) in the zone name. The *id* is optional; if it is not specified, the virtual channels are allocated by means of a round-robin scheme.

Priority	Name Format
High	QOSH <i>id_xxxxx</i>
Medium	QOSM <i>id_xxxxx</i>  <b>NOTE</b> For QOSM zones, the selection of flow id is not applicable; you can create a QOSM zone using the QOSM <i>id_xxxxx</i> format but the VC selection may not be honored. Refer to the entry on medium-priority traffic in the discussion of valid ID ranges below.
Low	QOSL <i>id_xxxxx</i>

As examples, "QOSH3\_HighPriorityTraffic" and "QOSL1\_LowPriorityZone" are both valid QoS zone names.

Each priority level is allocated to different virtual channels (VCs). High-priority flows receive more fabric resources than medium-priority flows, which receive more resources than low-priority flows. For example, you could assign online transaction processing (OLTP) to a high priority zone and backup traffic to a low priority zone. The flow *id* allows you to have control over the VC assignment and balancing the flows throughout the fabric.

The *id* range is as follows:

- 1-5 for high-priority traffic, which corresponds to VCs 10-14.
- 1-4 for medium-priority traffic, which corresponds to VCs 2-5. Note, however, that the virtual channels for medium-priority traffic are always allocated by a round-robin scheme, regardless of the *id* value.
- 1-2 for low-priority traffic, which corresponds to VCs 8 and 9.

The following figure shows a fabric with two hosts (H1, H2) and three targets (S1, S2, S3). The traffic prioritization is as follows:

- Traffic between H1 and S1 is high priority.
- Traffic between H1 and S3 and between H2 and S3 is low priority.
- All other traffic is medium priority, which is the default.

FIGURE 56 QoS traffic prioritization

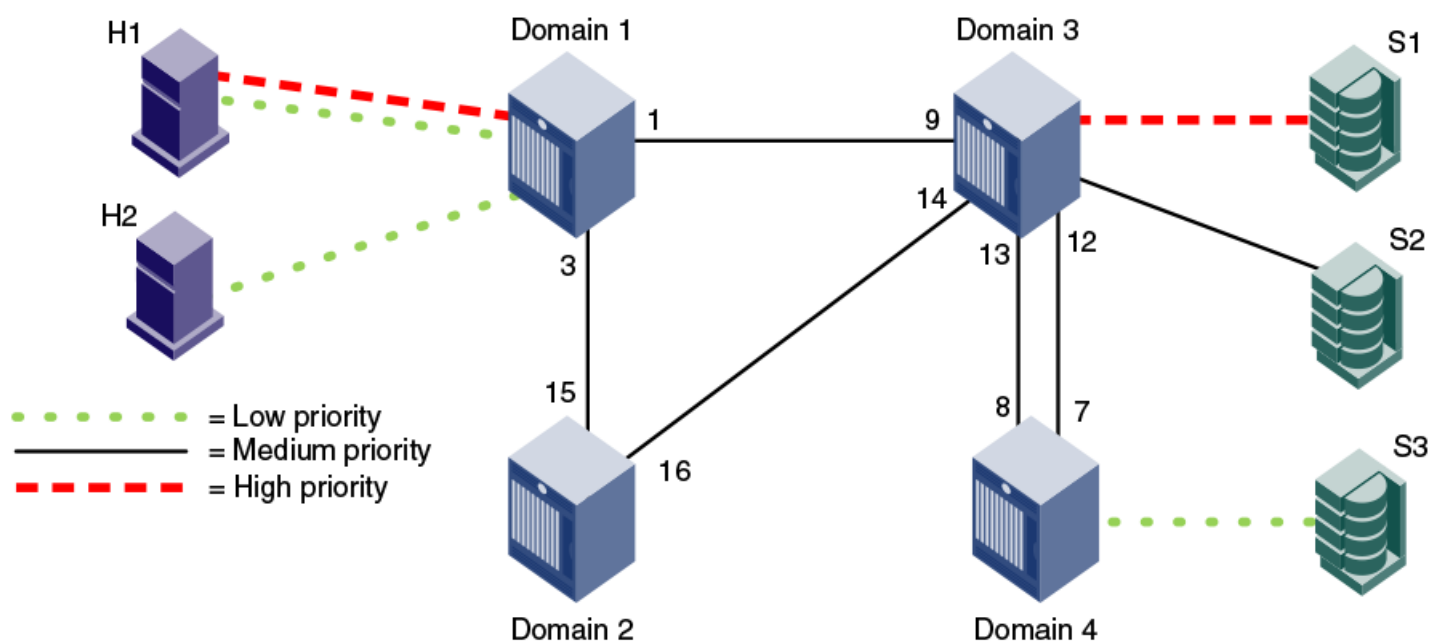

For this fabric, you could set up the following QoS zones:

QOSH\_Zone1 Members: H1, S1

QOSL\_Zone3 Members: H1, H2, S3

## Notes on QoS zoning

The following items should be kept in mind when working with QoS zoning:

- For new switches, QoS mode is automatically enabled on the E\_Ports, except for long-distance E\_Ports. For long-distance E\_Ports, you must manually enable QoS mode.
- If you upgrade to Fabric OS 7.2.0 or later from Fabric OS 7.1.x or earlier, and you did not previously have an Adaptive Networking license, then all ports that had QoS mode set to AE (automatically enabled) and were not using the QoS feature are automatically set to OFF after the upgrade. You must manually configure these ports for QoS.
- If a QoS zone name prefix is specified in an LSAN zone (a zone beginning with the prefix "LSAN\_"), the QoS tag is ignored. Only the first prefix in a zone name is recognized. For example, a zone with the name "LSAN\_QOSH\_zone1" is recognized as an LSAN zone and not a QoS zone. Refer to [QoS over FC routers](#) on page 390 for additional considerations when using QoS to prioritize traffic between device pairs in different edge fabrics.
- If there is a single low-priority flow to a destination ID (DID) and several medium-priority flows to that same DID, then it is possible that the medium-priority flows would have less bandwidth. This is because they have to share the medium-priority fabric resources, whereas the low-priority flow would have a separate set of fabric resources for its exclusive use.

## Setting QoS zone-based traffic prioritization

1. Connect to the switch and log in using an account with admin permissions.
2. Enter the **zoneCreate** command to create zones for high- and low-priority traffic.
  - For high-priority traffic, use the following syntax:

```
zonecreate "QOSHid_zonename", "member[; member...]"
```

- For low-priority traffic, use the following syntax:

```
zonecreate "QOSLid_zonename", "member[; member...]"
```

The *id* range is from 1 through 5 for high-priority traffic, which corresponds to VCs 10 through 14. For low-priority traffic, the *id* range is from 1 through 2, which corresponds to VCs 8 and 9. The *id* is optional; if it is not specified, the virtual channels are allocated by means of a round-robin scheme.

3. Enter the **cfgAdd** command to add the QoS zone to the zone configuration, by using the following syntax:

```
cfgadd "cfgname", "QOSzonename"
```

4. Enter the **cfgSave** command to save the change to the defined configuration.
5. Enter the **cfgEnable** command for the appropriate zone configuration to make the change effective.

```
cfgenable "cfgname"
```

6. Enter the **portCfgQos** command to enable QoS on the E\_Ports, by using the following syntax:

```
portcfgqos --enable [slot/]port
```

The **portCfgQos** command does not affect QoS prioritization. It only enables or disables the link to pass QoS priority traffic.

### NOTE

QoS is enabled by default on all ports (except long-distance ports). If you use the **portCfgQos** command to enable QoS on a specific port, the port is toggled to apply this configuration, even though the port already has QoS enabled. The port is toggled because the user configuration changed, even though the actual configuration of the port did not change. If you later use the **portCfgQos** command to enable QoS on the same port again, the port is *not* toggled, because the configuration did not change.

```

sw0:admin> zonecreate "QOSH1_zone", "10:00:00:00:10:00:00:00; 10:00:00:00:20:00:00:00"
sw0:admin> zonecreate "QOSL2_zone", "10:00:00:00:30:00:00:00; 10:00:00:00:40:00:00:00"
sw0:admin> zoneshow
sw0:admin> cfgadd "cfg1", "QOSH1_zone"
sw0:admin> cfgadd "cfg1", "QOSL2_zone"
sw0:admin> cfgshow
Defined configuration:
  cfg:  cfg1  QOSH1_zone; QOSL2_zone
  zone:  QOSH1_zone
         10:00:00:00:10:00:00:00; 10:00:00:00:20:00:00:00
  zone:  QOSL2_zone
         10:00:00:00:30:00:00:00; 10:00:00:00:40:00:00:00
Effective configuration:
No Effective configuration: (No Access)

sw0:admin> cfgsave
You are about to save the Defined zoning configuration. This
action will only save the changes on Defined configuration.
Any changes made on the Effective configuration will not
take effect until it is re-enabled. Until the Effective
configuration is re-enabled, merging new switches into the
fabric is not recommended and may cause unpredictable
results with the potential of mismatched Effective Zoning
configurations.
Do you want to save Defined zoning configuration only? (yes, y, no, n): [no] y
Updating flash ...

sw0:admin> cfgenable "cfg1"
You are about to enable a new zoning configuration.
This action will replace the old zoning configuration with the
current configuration selected. If the update includes changes
to one or more traffic isolation zones, the update may result in
localized disruption to traffic on ports associated with
the traffic isolation zone changes
Do you want to enable 'cfg1' configuration (yes, y, no, n): [no] y
zone config "cfg1" is in effect
Updating flash ...

sw0:admin> portcfgqos --enable 3

```

## Setting QoS zone-based traffic prioritization over FC routers

1. Connect to the switch in the edge fabric and log in using an account with admin permissions.
2. Create QoS zones in the edge fabric.

The QoS zones must have WWN members only, and not D.I members. Refer to [Setting QoS zone-based traffic prioritization](#) on page 395 for instructions.

3. Create LSAN zones in the edge fabric.

Refer to [Controlling device communication with the LSAN](#) on page 520 for instructions.

4. Enter the `portCfgQos --enable` command to enable QoS on the E\_Ports.

```
portcfgqos --enable [slot/]port
```

5. Repeat Step 1 through Step 3 to create QoS zones and LSAN zones on the other edge fabric.
6. Connect to the FC router in the backbone fabric and log in using an account with admin permissions.
7. Enter the `portCfgQos --enable` command to enable QoS on the EX\_Ports.

```
portcfgqos --enable [slot/]port
```



## Disabling QoS zone-based traffic prioritization

1. Connect to the switch and log in using an account with admin permissions.
2. Enter the **cfgRemove** command to remove the QoS zones from the current zone configuration.
 

```
cfgremove "configname" "qos_zonename"
```
3. Enter the **cfgEnable** command for the appropriate zone configuration to make the change effective.
 

```
cfgenable "configname"
```
4. Enter the **portCfgQos --disable** command to disable QoS on the E\_Ports.
 

```
portcfgqos --disable [slot/]port
```

## Supported configurations for QoS zone-based traffic prioritization

The following configuration rules apply to QoS zone-based traffic prioritization:

- All switches in the fabric must be running Fabric OS v6.0.0 or later.

### ATTENTION

If QoS traffic crosses an ISL for a switch running a firmware version earlier than Fabric OS v6.0.0, the frames are dropped.

- By default, all devices are assigned medium priority.
  - To be assigned high or low priority, hosts and targets must be connected to a Brocade 8-Gbps or 16-Gbps switch or port blade.
  - To preserve the priority level across ISLs, the switches must be running Fabric OS v6.0.0 or later.
- QoS is enabled by default on 8-Gbps and higher ports. QoS is disabled by default on all 4-Gbps ports and long-distance ports.

## Limitations and restrictions for QoS zone-based traffic prioritization

- Enabling and disabling QoS is potentially disruptive to the I/O on the affected port.
- If a host and target are included in two or more QoS zones with different priorities, the following priorities take precedence:
  - High and medium zones = High priority
  - High and low zones = Low priority
  - Medium and low zones = Low priority
  - High, medium, and low zones = Low priority

For example, if an effective zone configuration has QOSH\_z1 (H,T) and QOSL\_z2 (H,T), the traffic flow between H and T will be of low QoS priority.

- If QOSH\_z1 (H,T) overlaps with a D,I (domain,index) zone at the H port, the traffic flow between H and T is dropped to medium priority and the H port is marked as a session-based zoning port.
- Traffic prioritization is enforced on the egress ports only, not on the ingress ports.
- Traffic prioritization is not supported on mirrored ports.
- Traffic prioritization is not supported over LSAN zones beyond L2. The traffic is always medium priority in the ingress edge fabric, the backbone fabric, and the egress edge fabric.
- Traffic prioritization is not supported on a CryptoTarget container (redirection zone). Refer to the *Fabric OS Encryption Administrator's Guide* for information about redirection zones.
- Traffic prioritization is not supported in McDATA Fabric Mode (interopmode 2) or Open Fabric Mode (interopmode 3).
- QoS zones that use D,I notation are not supported for QoS over FCR.

- QoS zones that use D,I notation should not be used for loop or NPIV ports.
- If QoS is enabled, an additional 16 buffer credits are allocated per port for 8-Gbps ports in Extended Mode (LE). Refer to [Managing Long-Distance Fabrics](#) on page 483 for information about buffer credit allocation in extended fabrics.
- If some ports in a trunk group have QoS enabled and some ports have QoS disabled, then two different trunks are formed, one with QoS enabled and one with QoS disabled.
- QoS mode cannot be explicitly enabled on simulation ports (SIM ports). CS\_CTL mode can be enabled on SIM ports.

## CS\_CTL-based frame prioritization

CS\_CTL-based frame prioritization allows you to prioritize the frames between a host and a target as having high, medium, or low priority, depending on the value of the CS\_CTL field in the FC frame header.

The CS\_CTL field in the FC header can be used to assign a priority to a frame. This field can be populated by selected end devices (storage and host) and then honored by the switch, which assigns the frame, based on the value in the CS\_CTL field, to allocate appropriate resources throughout the fabric. This method of establishing QoS is an alternative to the switch-controlled assignment that uses zone-based QoS.

### ATTENTION

Check with your host and storage manufacturers to determine whether they support Fibre Channel CS\_CTL prioritization on their devices.

High-, medium-, and low-priority frames are allocated to different sets of fabric resources. High-priority frames are assigned more fabric resources than medium-priority frames, which in turn are assigned more fabric resources than low-priority frames. The resources are allocated according to the CS\_CTL value, as shown in [Table 76](#). The values are enabled by default to ensure backward compatibility.

**TABLE 76** Mapping of CS\_CTL values to QoS priority for frame prioritization in CS\_CTL default mode

CS_CTL value	Priority
1-8	Low
9-16	Medium
17-24	High

Alternatively, the user can apply CS\_CTL auto mode. The CS\_CTL auto mode uses only three CS\_CTL values, as illustrated in [Table 77](#).

**TABLE 77** Mapping of CS\_CTL values to QoS priority for frame prioritization in CS\_CTL auto mode

CS_CTL value	Priority
1	Low
2	Medium
3	High

### NOTE

The values in the tables represent chassis-level configurations. For configuration details, refer to [Using CS\\_CTL auto mode at the chassis level](#) on page 399, and [Considerations for using CS\\_CTL-based frame prioritization](#) on page 400.

## Supported configurations for CS\_CTL-based frame prioritization

CS\_CTL-based frame prioritization is supported on all 8-, 16-, and 32-Gbps platforms.

All switches in the fabric should be running Fabric OS v6.3.0 or later.

**NOTE**

If a switch is running a firmware version earlier than Fabric OS v6.3.0, the outgoing frames from that switch lose their priority.

## High availability considerations for CS\_CTL-based frame prioritization

If the standby CP is running a Fabric OS version earlier than 6.3.0 and is synchronized with the active CP, then you cannot enable CS\_CTL-based frame prioritization on the active CP. If the standby CP is not synchronized or if no standby CP exists, then enabling CS\_CTL-based frame prioritization succeeds.

## Enabling CS\_CTL-based frame prioritization on ports

Make sure that the CS\_CTL mode-enabled source and destination are zoned together.

When you enable CS\_CTL-based frame prioritization, you must enable it on both the source port and the destination port, so that the frames returned from the destination port for a given exchange always have the same CS\_CTL prioritization as the frames originating from the source port.

1. Connect to the switch and log in to an account that has admin permissions.
2. Enable CS\_CTL mode:

```
portcfgqos --enable [slot/]port csctl_mode
```

3. Enter **y** at the prompt to override QoS zone-based traffic prioritization.

## Disabling CS\_CTL-based frame prioritization on ports

When you disable CS\_CTL-based frame prioritization, QoS zone-based traffic prioritization is restored if it had been previously enabled.

1. Connect to the switch and log in to an account that has admin permissions.
2. Disable CS\_CTL mode using the **portCfgQos** command with the **--disable** option:

```
portcfgqos --disable [slot/]port csctl_mode
```

Alternatively, you can use the **--default** option to disable CS\_CTL mode and set QoS to auto-enable (AE):

```
portcfgqos --default [slot/]port
```

## Using CS\_CTL auto mode at the chassis level

You can use the CS\_CTL QoS mode options for the **configureChassis** command to change the chassis-wide default mode, as in the following example.

```
switch:admin> configurechassis
Configure...
  cfgload attributes (yes, y, no, n): [no]
  Custom attributes (yes, y, no, n): [no]
  system attributes (yes, y, no, n): [no]
  fos attributes (yes, y, no, n): [no] y
    CSCTL QoS Mode (0 = default; 1 = auto mode): (0..1) [0] 1
```

Set **CSCTL QoS Mode** to **1** to enable auto mode, establishing the settings shown in [Table 77](#) on page 398. Set **CSCTL QoS Mode** to **0** to disable auto mode and revert to default settings, shown in [Table 76](#) on page 398.

This is a chassis-level configuration. It does not provide options to enable CS\_CTL QoS on the ports.

**ATTENTION**

After changing the CS\_CTL QoS mode in a Chassis, you must run the **slotPowerOff/On** commands for all the edge blades; Whereas, in a fixed-port switch, you must reboot the switch. This is required for the new CS\_CTL QoS mode to become effective, because this mode change affects the persistent storage in the switch/chassis. To know the current mode, use the following command:

```
switch:admin> configshow -all | grep csctl
Default mode - fos.csctlMode:0
Auto mode - fos.csctlMode:1
```

## Considerations for using CS\_CTL-based frame prioritization

To use CS\_CTL for QoS on a given port for a given flow, proceed with the following steps.

1. Determine whether to use the default mode (refer to [Table 76](#) on page 398) or the auto mode (refer to [Table 77](#) on page 398). No choice results in the default mode.
2. In either case, ensure that the switch port connected to the initiator host and the switch port connected to the target host have `csctl_mode` enabled, as in [Enabling CS\\_CTL-based frame prioritization on ports](#) on page 399.
3. For a chassis based system, use the **slot poweroff – slot poweron** command pair for all the edge blades in the chassis. For a fixed-port switch, reboot the switch.

**ATTENTION**

Changing the CS\_CTL QoS mode using the **configureChassis** command is a disruptive operation. This command updates the chassis config and stores the information you provide in the chassis-level persistent data base. When the ASIC is initialized, it retrieves this information to initialize its CSCTL-VC table. You must power cycle all the edge blades in the chassis to have the new information be registered by the ASIC. For fixed-port switches, this requires a reboot of the entire switch. To know the current mode, use the following command:

```
switch:admin> configshow -all | grep csctl
Default mode - fos.csctlMode:0
Auto mode - fos.csctlMode:1
```

# In-flight Encryption and Compression

---

- In-flight encryption and compression overview.....401
- Configuring in-flight encryption and compression on an EX\_Port.....407
- Configuring in-flight encryption and compression on an E\_Port.....408
- Viewing the encryption and compression configuration.....409
- Configuring and enabling authentication for in-flight encryption.....409
- Enabling in-flight encryption.....412
- Enabling in-flight compression.....412
- Disabling in-flight encryption.....413
- Disabling in-flight compression.....414

## In-flight encryption and compression overview

### NOTE

In-flight encryption is not supported on any Gen 6 (32-Gbps) platform in Fabric OS release 8.0.1. However, In-flight compression is supported all Gen 6 (32-Gbps) platforms starting with Fabric OS 8.0.1.

In-flight encryption provides security for frames while they are in flight between two switches. In-flight compression provides better bandwidth use on the ISLs, especially over long distance.

The in-flight encryption and compression features allow frames to be encrypted or compressed at the egress point of an ISL between two Brocade switches, and then to be decrypted or decompressed at the ingress point of the ISL. Frames are never left in an encrypted or compressed state when delivered to an end device.

These features use port-based encryption and compression. You can enable the in-flight encryption and compression features for both E\_Ports and EX\_Ports on a per-port basis. By default, these features are initially disabled for all ports on a switch.

### NOTE

No license is required to configure and enable in-flight encryption or compression.

Both ends of the ISL must terminate in 16 Gbps-capable or 32 Gbps-capable FC ports.

Encryption and compression can be enabled at the same time, or you can enable either encryption or compression selectively. [Figure 57](#) shows an example of 16 Gbps links connecting three Brocade switches. One link is configured with encryption and compression, one with just encryption, and one with just compression.

FIGURE 57 Encryption and compression on 16 Gbps ISLs

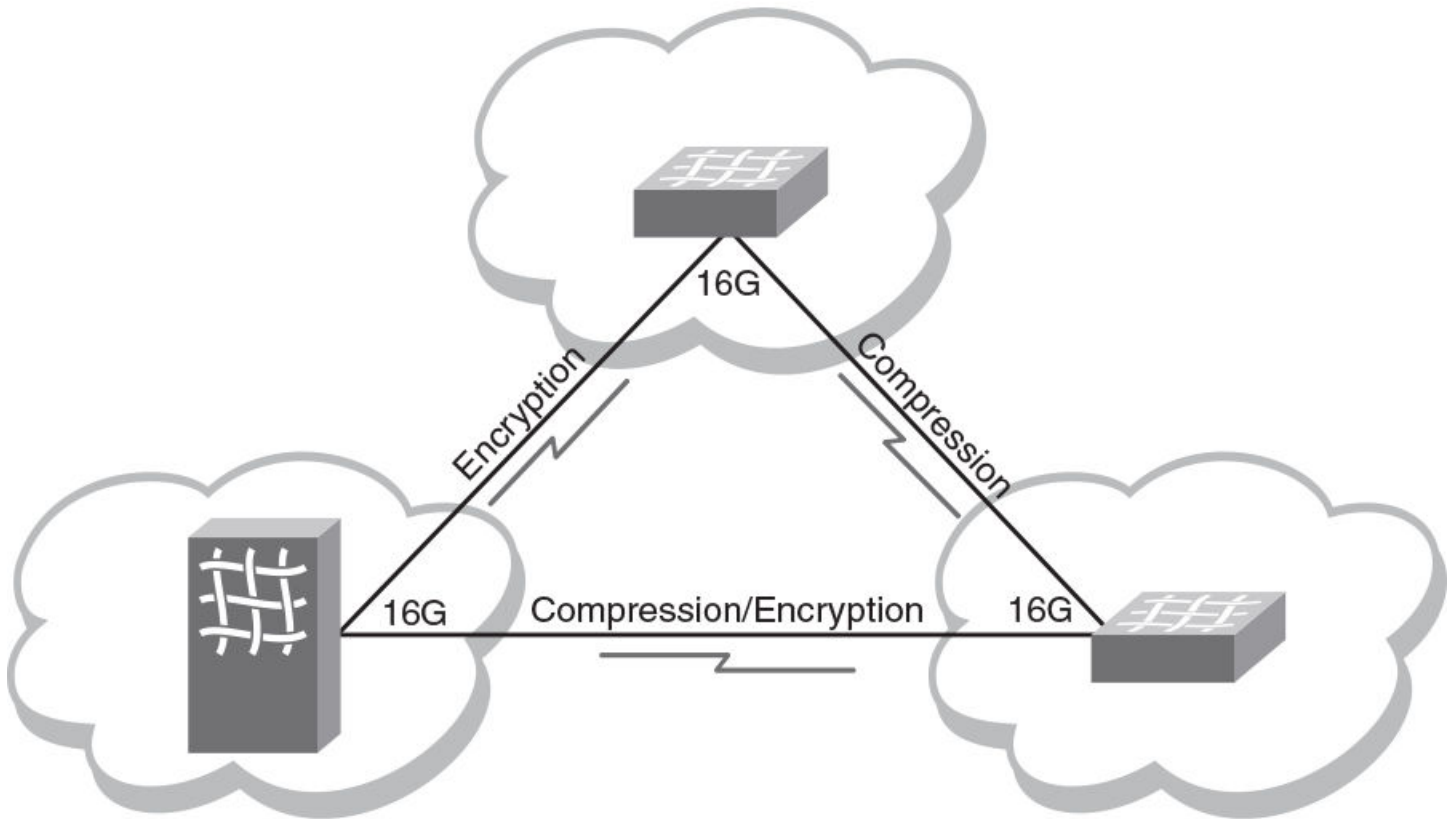

## Supported ports for in-flight encryption and compression

The in-flight encryption and compression features are supported only on E\_Ports and EX\_Ports, and only on the Brocade 6510, 6520, G620 switches, and 7840 extension switches, 16 Gbps Blade Server SAN I/O Modules, DCX 8510 Backbones and X6 Directors.

The ports can run at any speed, but must be 16 Gbps-capable or 32 Gbps-capable.

Encryption and compression are also compatible with the following features:

- E\_Ports or EX\_Ports with trunking, QoS, or long distance features enabled.
- Flow control modes: R\_RDY, VC\_RDY, and EXT\_VC\_RDY.
- XISL ports in VF mode.
- FCP data frames and non-FCP data frames except ELS and BLS frames.

FCP data frames are of Type = 0x8. For encryption, R\_CTL = 0x1 and R\_CTL = 0x4 are supported. For compression, only R\_CTL = 0x1 is supported.

Non-FCP data frames are of Type != 0x8. Non-FCP frames with ELS/BLS (R\_CTL == 0x2 || R\_CTL == 0x8) are not supported.

## In-flight encryption and compression restrictions

### NOTE

In-flight encryption is not supported on any Gen 6 (32-Gbps) platform in Fabric OS release 8.0.1. However, In-flight compression is supported all Gen 6 (32-Gbps) platforms starting with Fabric OS 8.0.1. A maximum of four ports per ASIC can be enabled with compression regardless of the port speed on 32-Gbps Gen 6 platforms.

- Ports must be 16 Gbps-capable or 32 Gbps-capable, although port speed can be any configurable value.
- The number of ports that can be configured is dynamic based on port speed. Refer to [Table 79](#) on page 403 for specific details about the number of ports supported for encryption and compression.
- The devices at either end of the ISL must run Fabric OS 7.0.0 or later software.
- Only E\_Ports, EX\_Ports, and XISL ports (in VF mode) support encryption or compression. ICL ports do not support encryption or compression.
- In-flight encryption is not FIPS certified.
- In a configuration with two switches with multiple ISLs connecting them, an encrypted and non-encrypted pair of links between two chassis is not allowed to work concurrently. Also, the transition from non-encrypted to encrypted ISLs between the two switches is disruptive.
- The payload size of a frame is restricted to 2048 bytes.
- Port mirroring through any encryption-enabled or compression-enabled port is not supported.

## Bandwidth and port limits for in-flight encryption and compression

Fabric OS 8.0.1 supports 64-Gbps of data compression per 32 Gbps-capable FC platform ASIC.

Fabric OS supports up to 32 Gbps of data encryption and 32 Gbps of data compression per 16 Gbps-capable FC platform ASIC.

This limits the number of ports that can have these features enabled at any one time.

The port speed affects the number of supported ports. The slower the speed, the more ports are supported. In general, at 16 Gbps, the number of supported ports is 2 per ASIC or trunk. At 32 Gbps, maximum of four ports per ASIC support compression regardless of the speed.

The following table shows some examples of how port speed affects the number of supported ports for different implementations.

**TABLE 78** Gen 6: Number of ports supported for in-flight encryption and compression at various port speeds

Port Speed	Compression only (G620 switch)	Compression only (FC 32-48 blade)
32-Gbps	4 ports	4 ports
16-Gbps	4 ports	4 ports
10-Gbps	4 ports	4 ports
8-Gbps	4 ports	4 ports
Auto-negotiate (AN)	4 ports	4 ports

**TABLE 79** Gen 5: Number of ports supported for in-flight encryption and compression at various port speeds

Port speed	Encryption only	Compression only	Encryption and compression
	<b>Blades (FC16-32, FC16-48, FC16-64)<sup>9</sup></b>		
16 Gbps	4 ports	4 ports	4 ports
10 Gbps	6 ports	6 ports	6 ports
8/4/2 Gbps	8 ports	8 ports	8 ports

**TABLE 79** Gen 5: Number of ports supported for in-flight encryption and compression at various port speeds (continued)

Port speed	Encryption only	Compression only	Encryption and compression
Auto-negotiate (AN)	4 ports	4 ports	4 ports
<b>6510 Fixed-port switches and 16 Gbps Blade Server SAN I/O Modules<sup>10</sup></b>			
16 Gbps	2 ports	2 ports	2 ports
10 Gbps	3 ports	3 ports	3 ports
8/4/2 Gbps	4 ports	4 ports	4 ports
Auto-negotiate (AN)	2 ports	2 ports	2 ports
<b>6520 Fixed-port switches<sup>11</sup></b>			
16 Gbps	8 ports	8 ports	8 ports
10 Gbps	12 ports	12 ports	12 ports
8/4/2 Gbps	16 ports	16 ports	16 ports
Auto-negotiate (AN)	8 ports	8 ports	8 ports

This table does not show all the possible combinations of different speeds for the encryption and compression ports; other combinations are also supported. The number of supported ports is automatically calculated based on the speeds chosen.

### Port speed on encryption- or compression-enabled ports

The port speed determines the maximum number of ports on a device that can support the in-flight encryption and compression features.

#### NOTE

This section applies only to Gen 5 (16-Gbps) platforms.

If the port speed is configured as AUTO NEG, the speed of the port is taken as 16 Gbps for calculation purposes. It is recommended that you configure the ports to a specific speed before enabling encryption or compression.

The port speed values can be displayed through several commands, including `portEncCompShow`, `portShow`, and `switchShow`.

You can change the port speed on any port that has encryption or compression enabled with the `portCfgSpeed` command. If the capacity is available, the port is configured with the new speed. If there is not enough capacity available, you cannot change the port speed.

Refer to [Setting port speeds](#) on page 83 for more information.

### How in-flight encryption and compression are enabled

Encryption and compression capabilities and configurations from each end of the ISL are exchanged during E\_Port or EX\_Port initialization. Capabilities and configurations must match, otherwise port segmentation or disablement occurs.

If the port was configured for compression, then the compression feature is enabled.

If the port was configured for encryption, authentication is performed and the keys needed for encryption are generated. The encryption feature is enabled if authentication is successful. If authentication fails, then the ports are segmented.

<sup>9</sup> The port blades have two ASICs; the per ASIC limit = numbers above/two

<sup>10</sup> The Brocade 6510 switch and 16 Gbps Blade Server SAN I/O Modules have one ASIC; the per ASIC limit = numbers above

<sup>11</sup> The Brocade 6520 has four edge ASICs; the per ASIC limit = numbers above/four



**ATTENTION**

Any mismatch in configuration at either end of the IFL or authentication failure results in segmentation or, in rare cases, the port being disabled.

The most common reasons for E\_Port or EX\_Port segmentation include the following situations:

- Port authentication fails. One of the following error messages is displayed:  

```
Authentication Rejected
Authentication Failure
```
- Encryption or compression configurations do not match at both ends. For example, if at one end there is a switch that does not support encryption or compression, the port will be disabled. One of the following error messages is displayed:  

```
Compression configuration mismatch
Encryption configuration mismatch
```
- An encryption or compression configuration is enabled but resources are not available, or there are other failures preventing encryption or compression from being enabled. The following error message is displayed.  

```
Encryption/Compression enabled but resource unavailable
```
- The number of available ports has reached the bandwidth limitation.

**NOTE**

If trunking is enabled, be aware that the ports creating the bandwidth limitation will form a trunk group, while the rest of the ports will be segmented.

You can also decommission any port that has in-flight encryption and compression enabled. Refer to [Port decommissioning](#) on page 83 for details on decommissioning ports.

## Authentication and key generation for encryption and compression

The following points apply to authentication and key generation on the supported devices:

- Authentication and key generation only apply to ports that are configured for encryption. They do not apply to ports that are only configured for compression.
- Authentication using FCAP or DH-CHAP is supported between E\_Ports and F\_Ports connecting Brocade switches and Access Gateway devices. However, EX\_Ports only support authentication using DH-CHAP. This means that if an inter-fabric link (IFL) must be authenticated, the authentication type on edge fabric should be set to either DH-CHAP or ALL. Configuration done in FCR using the **authUtil** command is applicable only for backbone fabric (E\_Ports in FCR, not EX\_Ports). Authentication parameters for FCR cannot be modified.
  - Default configuration:
    - > Authentication Type - DH-CHAP
    - > Hash Type - SHA256, SHA1, md5
    - > Group Type - 0,1,2,3,4
    - > Switch Authentication Policy - Passive
  - FIPS mode configuration:
    - > Authentication Type - DH-CHAP
    - > Hash Type - SHA256, SHA1
    - > Group Type - 4
    - > Switch Authentication Policy - Passive

- The in-flight encryption protocol supports the AES-GCM authenticated encryption block cipher mode. A key, Initial Vector (IV), segment number, and salt are required to encrypt the data before it is transmitted, and to decode the data after it is received on the other end of the link.
- In-flight encryption feature uses DH-CHAP(Diffie Hellman – Challenge Handshake Authentication Protocol) or Fibre Channel Authentication Protocol (FCAP) for authentication and key generation for secure frame transaction.
- In the in-flight encryption process, a session key will be generated during authentication phase and it will be used in IKE (Internet Key Exchange) protocol session to generate and exchange encryption/decryption keys for packet encryption/decryption between two devices.
- For in-flight encryption using DH-CHAP, DH-CHAP must be configured along with DH group 4 and pre-shared secret keys on the devices on both ends of the ISL as a pre-requisite. Authentication secrets greater than 32 characters are recommended for stronger encryption keys. Once the link is authenticated, the keys are generated and exchanged.
- For in-flight encryption using FCAP, FCAP must be configured along with DH group 4 and certificates (CA and switch) at both ends of ISL as a pre-requisite.
- The encryption keys never expire. While the port remains online, the keys generated for the port remain the same. When a port is disabled, segmented, or taken offline, a new set of keys is generated when the port is enabled again.
- All members of a trunk group use the same set of keys as the master port. Slave ports do not exchange keys. If the master port goes offline causing an E\_Port or EX\_Port change, the trunk continues to use the same set of keys.

## Availability considerations for encryption and compression

To provide redundancy in the event of encryption or compression port failures, you should connect each ISL or trunk group to different ASICs on the peer switch.

For FC16-32, FC16-48, FC16-64 blades, if the two ports configured for encryption or compression within the same ASIC are not configured for trunking, it is recommended to connect each ISL to a different ASIC on the peer switch. Similarly, configure the two ports on the other ASIC of the blade. If the ports are configured for trunking, it is recommended to connect each trunk group to different ASICs on the peer switch.

For Brocade 6510 and 6520 switches, and 16 Gbps Blade Server SAN I/O Modules, if the two ports are not configured for trunking, it is recommended that you connect each ISL to different ASICs on the peer switch.

For FC32-48 blades and G620 switch, four ports per ASIC can be configured with compression.

### NOTE

If any port with encryption enabled encounters rare error conditions that require error recovery to be performed on the encryption engine within that ASIC, all encryption or compression-enabled ports on that ASIC go offline.

## Virtual Fabrics considerations for encryption and compression

The E\_Ports and EX\_Ports in the user-created logical switch, base switch, or default switch, and the EX\_Ports on base switches can support encryption and compression, with some exceptions.

You can configure encryption on XISL ports, but not on LISL ports. However, frames from the LISL ports are implicitly encrypted or compressed as they pass through encryption- or compression-enabled XISL ports.

You cannot move a port from one logical switch to another logical switch if in-flight encryption or compression is enabled on the port. You must disable the encryption and compression configurations before moving the port, and then enable encryption and compression after the port has moved.

## In-flight compression on long-distance ports

When configuring in-flight compression on long-distance ports, it is recommended to configure the long-distance ports with double the number of buffers.

Configure the port to use the long-distance LS mode and specify the number of buffers to allocate to the port. You can see what the average compression ratio and the average frame size values are and adjust the allocated credit accordingly using the **portEncCompShow** and **portBufferShow** commands. You can then use the **portBufferCalc** command to estimate the assigned credit value to optimize performance.

## Compression ratios for compression-enabled ports

An average compression ratio of 2:1 is provided. The compression ratio value is recalculated every five seconds, and is the ratio between the accumulated original length and the compressed length of the data over the previous five seconds.

When a port is configured for compression, entering **portStatsShow** displays the port's compression ratio. The value shown by **portStatsShow** is a five-second average. Your results depend on the pattern of the payload data.

The ASIC Compression Block can compress data only if there is at least 3 bytes of data.

The **portBufferShow** command shows the average frame size for both received (rx) and transmitted (tx) frames. The rx values are after compression and the tx values are before compression.

Because encryption adds more payload to the port in addition to compression, the compression ratio calculation is significantly affected on ports configured for both encryption and compression. This is because the compressed length then also includes the encryption header. This overhead affects the ratio calculation. To obtain accurate compression ratio data, it is recommended that you enable ports for compression only.

## Configuring in-flight encryption and compression on an EX\_Port

When you configure in-flight encryption and compression across an IFL, first configure the EX\_Port and then configure the E\_Port. The encryption and compression settings must match at either end of the IFL.

The following steps summarize how to enable in-flight encryption or compression on an EX\_Port. Perform these steps on the FC router.

1. Determine which ports are available for encryption or compression.  
Refer to [Viewing the encryption and compression configuration](#) on page 409 for instructions.
2. Obtain the WWN of the edge switch using the **fcrEdgeShow** command.

You need this WWN when you set up the secret key.

```
switch:admin> fcredgeshow
```

FID	EX-port	E-port	Neighbor Switch (PWWN, SWWN)	Flags
20	1	1	20:01:00:05:33:13:70:3e 10:00:00:05:33:13:70:3e	

3. If you are enabling encryption on the port, configure port level authentication for the port.  
Omit this step if you want to enable only compression on the port.  
Refer to [Configuring and enabling authentication for in-flight encryption](#) on page 409 for instructions.
4. Enable encryption on the port.  
Refer to [Enabling in-flight encryption](#) on page 412 for instructions.
5. Enable compression on the port.

Refer to [Enabling in-flight compression](#) on page 412 for instructions.

- Obtain the WWN of the front phantom domain using the `portCfgExPort` command.

You need this WWN when you set up the secret key on the E\_Port on the other end of the IFL.

```
FCR:admin> portcfgexport 1

      Port 1 info
Admin:                enabled
State:                OK
Pid format:           core(N)
Operate mode:         Brocade Native
Edge Fabric ID:       20
Front Domain ID:      160
Front WWN:            50:00:53:31:37:43:ee:14
Principal Switch:     8
(output truncated)
```

You can also specify a port range per blade in chassis based FCR. However, the range should not include a SIM\_Port.

For example, the following sample sets the range of EX\_Ports as FCR ports:

```
DCX:root> portcfgexport 1/1-2 -a 1
2014/09/15-07:09:12, [FCR-1071], 11763, SLOT 6 | FID 128, INFO, DCX, Port 1/1 is changed from non
FCR port to FCR port.
2014/09/15-07:09:13, [FCR-1071], 11764, SLOT 6 | FID 128, INFO, DCX, Port 1/2 is changed from non
FCR port to FCR port.
```

The following sample sets the range of EX\_Ports as non-FCR ports:

```
DCX:root> portcfgexport 1/1-2 -a 2
2014/09/15-07:09:17, [FCR-1072], 11765, SLOT 6 | FID 128, INFO, DCX, Port 1/1 is changed from FCR
port to non FCR port.
2014/09/15-07:09:18, [FCR-1072], 11766, SLOT 6 | FID 128, INFO, DCX, Port 1/2 is changed from FCR
port to non FCR port.
```

Following successful port initialization, the configured features are enabled and active. You can use the `fcrEdgeShow` command to check that the EX\_Port has come online with encryption or compression enabled.

Next, configure encryption and compression on the E\_Port at the other end of the IFL.

## Configuring in-flight encryption and compression on an E\_Port

The following steps summarize how to enable encryption or compression on an E\_Port.

To configure in-flight encryption and compression across an IFL, first configure encryption and compression on the EX\_Port in the FC router.

Perform the following steps to configure the E\_Port in the switch.

- Determine which ports are available for encryption or compression.  
Refer to [Viewing the encryption and compression configuration](#) on page 409 for instructions.
- If you are enabling encryption on the port, configure port level authentication for the port.  
Omit this step if you want to enable only compression on the port.  
Refer to [Configuring and enabling authentication for in-flight encryption](#) on page 409 for instructions.
- Enable encryption on the port.  
Refer to [Enabling in-flight encryption](#) on page 412 for instructions.
- Enable compression on the port.

Refer to [Enabling in-flight compression](#) on page 412 for instructions.

Following successful port initialization, the configured features are enabled and active. You can use the **islShow** command to check that the E\_Port has come online with encryption or compression enabled. Alternatively, you can use the **portEncCompShow** command to see which ports are active.

If port initialization is not successful, you can check for port segmentation errors with the **switchShow** command. This command will tell you if the segmentation was due to mismatched encryption or compression configurations on the ports at either end of the ISL, if port-level authentication failed, or if a required resource was not available.

## Viewing the encryption and compression configuration

Before enabling ports for in-flight encryption or compression, you should determine which ports are available. Enabling encryption or compression fails if you try to exceed the number of allowable ports available for encryption or compression on the ASIC.

1. Connect to the switch and log in using an account with admin permissions.
2. Enter the **portEncCompShow** command.

The following example shows the output for two ASICs.

ASIC 1 (below the line of dashes) already has compression configured and active on user ports 348 and 349. Given the limit of two ports per ASIC, ASIC 1 has no more ports available for encryption or compression.

ASIC 0 (above the dashed line) has no ports configured for either encryption or compression and therefore has any two ports available for this purpose.

```
switch:admin> portenccompshow
```

User Port	Encryption		Compression		Config Speed
	Configured	Active	Configured	Active	
17	No		No	No	No 4G
18	No		No	No	No 4G
19	No		No	No	No 4G
(output truncated)					
149	No		No	No	No 4G
150	No		No	No	No 4G
151	No		No	No	No 4G
-----					
88	No		No	No	No 4G
89	No		No	No	No 4G
90	No		No	No	No 4G
(output truncated)					
348	No		No	Yes	Yes 4G
349	No		No	Yes	Yes 4G
350	No		No	No	No 4G
351	No		No	No	No 4G

The output displays the user port number. For bladed switches, use the **switchShow** command to determine the slot number of a specific user port.

## Configuring and enabling authentication for in-flight encryption

Authentication and a secret key must be configured and established before configuring in-flight encryption.

To enable authentication between an FC router and an edge fabric switch, you must first bring all EX\_Ports online without using authentication. After this, the front WWN of any online EX\_Port connected to the same switch can be used to configure the secret keys in the edge fabric switch.

You must obtain the WWN of the peer switch to configure the secret key. If you are configuring an EX\_Port on an FC router, you can use the **fcEdgeShow** command to obtain the WWN of the switch at the other end of the IFL.

#### NOTE

Only DH-CHAP authentication is supported for in-flight encryption of EX\_Ports.

1. Log in to the switch using an account with admin permissions, or an account with OM permissions for the Authentication RBAC class of commands.

#### ATTENTION

When setting a *secret key pair*, you are entering the shared secrets in plain text. Use a secure channel, such as SSH or the serial console, to connect to the switch on which you are setting the secrets.

2. Configure DH-CHAP or FCAP for authentication using the **authUtil --set** command with the **-a** option.

```
switch:admin> authutil --set -a dhchap
Authentication is set to dhchap.
```

You can specify any one of the following options:

- **dhchap**
- **fcap**
- **all**

The **dhchap** option sets authentication protocol to DH-CHAP. The **fcap** option sets authentication protocol to FCAP. Although **all** enables both FCAP and DH-CHAP, the active protocol defaults to FCAP for all ports configured for in-flight encryption.

If **dhchap** is specified, then all switches in the fabric must enable DH-CHAP and establish pre-shared secrets. If **fcap** is specified, then all switches in the fabric must enable FCAP and use certificates (CA and switch) installed on them. If the protocol is set to **all**, you must establish pre-shared secrets or certificates based on the encryption method selected (DH-CHAP or FCAP).

3. Set the DH group to group 4 using the **authUtil --set** command with the **-g** option.

```
switch:admin> authutil --set -g "4"
DH Group was set to 4.
```

You can specify either **"4"** or **""**. The **"4"** option explicitly enables DH group 4. Although **""** enables all DH groups (0 through 4), the DH group defaults to group 4 for all ports configured for in-flight encryption.

4. Configure pre-shared keys or certificates based on the encryption method selected (DH-CHAP or FCAP):
  - If DH-CHAP is the configured authentication protocol, use the **secAuthSecret --set** command to establish pre-shared secret key at each end of the ISL. It is recommended to use a 32-bit secret for an ISL carrying encrypted or compressed traffic.

```
switch:admin> secauthsecret --set
```

When prompted, enter the WWN for the remote switch and secret strings for the local switch and the remote switch.

- If FCAP is the configured authentication protocol, use the **seccertutil** command to generate the public or private key, the CSR, and the passphrase and then import certificates (CA and switch) at both the ends of ISL.

```
switch:admin> seccertutil
```

5. Activate the configured authentication using the **authUtil --policy** command to set the switch policy mode to Active or On.

```
switch:admin> authutil --policy -sw active
```

If you are configuring authentication on an EX\_Port, there is no need to set the authentication policy to Active or On. EX\_Ports can operate on any switch authentication policy.

- Verify the authentication configuration using the `authUtil --show` command.

The following example sets up authentication in preparation for in-flight encryption. Specifically, it configures DH-CHAP for authentication, sets the DH group to group 4, sets up a pre-shared secret key, and activates authentication.

```
switch:admin> authutil --set -a dhchap
```

```
Authentication is set to dhchap.
```

```
switch:admin> authutil --set -g "4"
```

```
DH Group was set to 4.
```

```
switch:admin> secauthsecret --set
```

This command is used to set up secret keys for the DH-CHAP authentication. The minimum length of a secret key is 8 characters and maximum 40 characters. Setting up secret keys does not initiate DH-CHAP authentication. If switch is configured to do DH-CHAP, it is performed whenever a port or a switch is enabled.

Warning: Please use a secure channel for setting secrets. Using an insecure channel is not safe and may compromise secrets. Following inputs should be specified for each entry.

- WNN for which secret is being set up.
- Peer secret: The secret of the peer that authenticates to peer.
- Local secret: The local secret that authenticates peer.

```
Press enter to start setting up secrets >
```

```
Enter peer WNN, Domain, or switch name (Leave blank when done): 10:00:00:05:1e:e5:cb:00
```

```
Enter peer secret:
```

```
Re-enter peer secret:
```

```
Enter local secret:
```

```
Re-enter local secret:
```

```
Enter peer WNN, Domain, or switch name (Leave blank when done):
```

```
Are you done? (yes, y, no, n): [no] y
```

```
Saving data to key store... Done.
```

```
switch:admin> secauthsecret --show
```

```
WNN                               DId    Name
-----
10:00:00:05:1e:e5:cb:00          150    dcx_150
```

```
switch:admin> authutil --policy -sw active
```

Warning: Activating the authentication policy requires either DH-CHAP secrets or PKI certificates depending on the protocol selected. Otherwise, ISLs will be segmented during next E-port bring-up.  
ARE YOU SURE (yes, y, no, n): [no] y

```
Auth Policy is set to ACTIVE
```

```
switch:admin> authutil --show
```

```
AUTH TYPE      HASH TYPE      GROUP TYPE
-----
dhchap         md5            4
Switch Authentication Policy: ACTIVE
Device Authentication Policy: OFF
```

For additional information about configuring DH-CHAP and FCAP authentication protocols, refer to [Authentication policy for fabric elements](#) on page 227.

## Enabling in-flight encryption

Enable in-flight encryption to provide security for frames while they are in flight between two switches. Frames are encrypted at the egress point of an ISL and then decrypted at the ingress point.

Enabling encryption is an offline event. Ports must be disabled first, and then re-enabled after.

Before performing this procedure, it is recommended that you check for port availability. Enabling encryption fails if you try to exceed the number of allowable ports available for encryption or compression on the ASIC. Refer to [Viewing the encryption and compression configuration](#) on page 409 for details.

You must also authenticate the port as described in [Configuring and enabling authentication for in-flight encryption](#) on page 409.

1. Connect to the switch and log in using an account with secure admin permissions, or an account with OM permissions for the EncryptionConfiguration RBAC class of commands.
2. Enter the **portDisable** command to disable the port on which you want to configure encryption.
3. Enter the **portCfgEncrypt --enable** command.

The following example enables encryption on port 15 of an FC16-32 blade in slot 9 of an enterprise class platform:

```
switch:admin> portcfgencrypt --enable 9/15
```

4. Enter the **portEnable** command to enable the port.

After manually enabling the port, the new configuration becomes active.

The following example enables in-flight encryption on port 0.

```
switch:admin> portdisable 0
switch:admin> portcfgencrypt --enable 0
switch:admin> portenable 0
```

You can verify the configuration using the **portCfgShow** command.

```
switch:admin> portcfgshow 0
Area Number:          0
Octet Speed Combo:   3 (16G,10G)
(output truncated)
D-Port mode:         OFF
D-Port over DWDM:    ..
Compression:         OFF
Encryption:          ON
```

## Enabling in-flight compression

Enable in-flight compression to provide better bandwidth use on the ISLs, especially over long distance. Frames are compressed at the egress point of an ISL and then decompressed at the ingress point.

Enabling compression is an offline event. Ports must be disabled first, and then re-enabled after.

Before performing this procedure, it is recommended that you check for port availability. Enabling compression fails if you try to exceed the number of allowable ports available for encryption or compression on the ASIC. Refer to [Viewing the encryption and compression configuration](#) on page 409 for details.



1. Connect to the switch and log in using an account with admin permissions, or an account with OM permissions for the SwitchPortConfiguration RBAC class of commands.
2. Enter the **portDisable** command to disable the port on which you want to configure compression.
3. Enter the **portCfgCompress --enable** command to enable compression.

The following example enables compression on port 15 in slot 9 of an enterprise class platform:

```
switch:admin> portcfgcompress --enable 9/15
```

4. Enter the **portEnable** command to enable the port.

After enabling the port, the new configuration becomes active.

The following example enables compression on port 0.

```
switch:admin> portdisable 0
switch:admin> portcfgcompress --enable 0
switch:admin> portenable 0
```

You can verify the configuration using the **portCfgShow** command.

```
switch:admin> portcfgshow 0
Area Number:          0
Octet Speed Combo:   3 (16G,10G)
(output truncated)
D-Port mode:         OFF
D-Port over DWDM:    ..
Compression:         ON
Encryption:          ON
```

## Disabling in-flight encryption

Disabling encryption is an offline event. Ports must be disabled first, and then re-enabled after.

1. Connect to the switch and log in using an account with secure admin permissions, or an account with OM permissions for the EncryptionConfiguration RBAC class of commands.
2. Disable the port using the **portDisable** command.
3. Disable encryption on the port using the **portCfgEncrypt --disable** command.

The following example disables encryption on port 15 in slot 9 of an enterprise class platform:

```
switch:admin> portcfgencrypt --disable 9/15
```

4. Enable the port using the **portEnable** command.

The following example disables encryption on port 0.

```
myswitch:admin> portdisable 0
myswitch:admin> portcfgencrypt --disable 0
myswitch:admin> portenable 0
```

You can verify the configuration using the **portCfgShow** command.

```
myswitch:admin> portcfgshow 0
Area Number:          0
```

```

Speed Level:          AUTO (SW)
(output truncated)
D-Port mode:         OFF
D-Port over DWDM    ..
Compression:         OFF
Encryption:          OFF

```

## Disabling in-flight compression

Disabling compression is an offline event. Ports must be disabled first, and then re-enabled after.

### NOTE

Firmware downgrade from Fabric OS 7.3.0 to an earlier version is blocked if in-flight encryption with FCAP protocol is set. Please set the DHCHAP protocol using the **authutil --set** command before downgrade.

1. Connect to the switch and log in using an account with admin permissions, or an account with OM permissions for the SwitchPortConfiguration RBAC class of commands.
2. Disable the port using the **portDisable** command.
3. Disable compression on the port using the **portCfgCompress --disable** command.

The following example disables compression on port 15 in slot 9 of an enterprise class platform:

```
switch:admin> portcfgcompress --disable 9/15
```

4. Enable the port using the **portEnable** command.

You can verify the configuration using the **portCfgShow** command.

```

myswitch:admin> portcfgshow 0

Area Number:          0
Speed Level:          AUTO (SW)
(output truncated)
D-Port mode:         OFF
D-Port over DWDM    ..
Compression:         OFF

Encryption:          OFF

```

The following example disables compression on port 0.

```

myswitch:admin> portdisable 0
myswitch:admin> portcfgcompress --disable 0
myswitch:admin> portenable 0

```

# Diagnostic Port

- Supported platforms for D\_Port..... 415
- Licensing requirements for D\_Port..... 416
- Understanding D\_Port..... 416
- Topology 1: ISLs..... 421
- Topology 2: ICLs..... 422
- Topology 3: Access Gateways..... 422
- Topology 4: HBA to switch..... 424
- Using D\_Port in static-static mode between switches..... 425
- Using D\_Port in dynamic mode..... 427
- Using D\_Port between switches and HBAs..... 429
- Using D\_Port in on-demand mode ..... 433
- Using D\_Port show commands..... 433

## Supported platforms for D\_Port

The ports use Brocade-branded or certain Brocade-qualified SFP/QSFP transceivers. D\_Port functionality is supported on the following Gen 5 and Gen 6 Fibre Channel (FC) platforms.

**TABLE 80** Supported platforms for D\_Port with Fabric OS

Platform	SFP	QSFP
Gen 5	<ul style="list-style-type: none"> <li>• 10/16-Gbps FC</li> <li>• 8/16-Gbps Long Wave Length (LWL) FC</li> <li>• 8/16-Gbps Extended Long Wave Length (ELWL) FC</li> </ul>	<ul style="list-style-type: none"> <li>• 16 Gbps</li> </ul>
Gen 6	<ul style="list-style-type: none"> <li>• 10/16/32-Gbps FC</li> <li>• 16/32-Gbps LWL FC</li> <li>• 8/16-Gbps ELWL FC</li> </ul>	<ul style="list-style-type: none"> <li>• 16/32 Gbps</li> </ul>

The following table lists the Brocade devices and Fabric OS releases that support the D\_Port feature.

**TABLE 81** Supported devices for D\_Port with Fabric OS

Product	Fabric OS release and later
Brocade DCX 8510-4 Backbone	7.0.0
Brocade DCX 8510-8 Backbone	7.0.0
Brocade 6505 switch	7.0.1
Brocade 6510 switch	7.0.0
Brocade 6520 switch	7.1.0
Brocade 7840 switch	7.3.0
Brocade G620 switch	8.0.0
Brocade X6-8 switch	8.0.1
Brocade X6-4 switch	8.0.1

D\_Port functionality is supported on the following HBAs:

- Brocade 16-Gbps HBA (Brocade Fabric Adapter 1860) ports operating in HBA mode with a 16-Gbps SFP+ on Brocade 16-Gbps switches running Fabric OS version 7.1 or later.
- Non-Brocade 16-Gbps HBAs: Emulex LPe16002B-M6, QLogic QLE-2672, QLogic 1860-2P
- Non-Brocade 32-Gbps HBAs: Emulex LPe32000B, QLogic QLE2764, QLogic QLE2742

Brocade HBA v3.1 provides limited support for D\_Port. Brocade HBA v3.2 provides extensive support for D\_Port, including dynamic D\_Port mode.

- Non-Brocade 16-Gbps HBAs (must have HBA D\_Port support)

For applicable topologies, refer to "Supported topologies" in this chapter.

For D\_Port functionality with 8-Gbps SFP transceivers, the switch must be running Fabric OS 7.2.1 or later.

To run D\_Port tests on a link with 8-Gbps SFP transceivers, both ends of the link must have the same type of SFP. That is, both ends of the link must have LWL SFPs or both ends must have ELWL SFPs.

## Licensing requirements for D\_Port

The D\_Port feature does not require a license if you are running tests between a pair of Brocade devices, whether the devices are switches, Access Gateways, or HBAs.

If you want to run D\_Port tests between a switch and a non-Brocade HBA, the Fabric Vision license for Gen6 and Gen5 or the combination of the Fabric Watch license and the Advanced Performance Monitoring license for Gen5 only is required. Also, the HBA vendor must have implemented Brocade HBA D\_Port support.

Starting with Fabric OS 7.3.2, you can also run D\_Port tests if you have a Fabric Watch and Performance Monitor combo license.

## Understanding D\_Port

A port in D\_Port mode does not carry any user traffic, and is designed to run only specific diagnostics tests for identifying link-level faults or failures.

To bring up a port in D\_Port mode, follow these basic steps:

1. Disable the ISL capability on the ports by issuing the **no fabric isl enable** command.
2. Enable D\_Port functionality on both ends of the link.
3. Enable the ISL capability on the ports by issuing the **fabric isl enable** command.

The following figure illustrates an example D\_Port connection between a pair of switches through SFP transceivers (port assignments will vary).

### NOTE

With Gen 6, Fabric OS supports 10-, 16-, and 32-Gbps connections.

FIGURE 58 Example of a basic D\_Port connection between switches

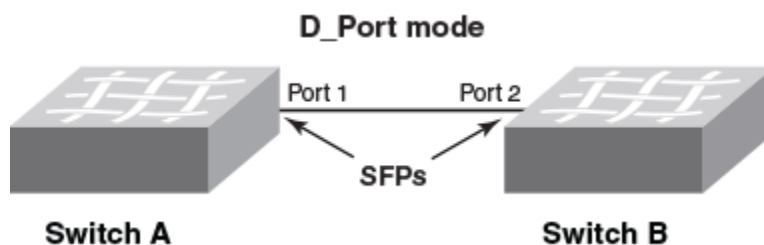

Once the ports are configured and enabled as D\_Ports, the following basic test suite is executed in the following order, depending on the SFPs installed:

1. Electrical loopback (with 16/32-Gbps SFP+ and QSFP)
2. Optical loopback (with 16/32-Gbps SFP+ and QSFP)
3. Link latency, distance, and power measurement (with 8-Gbps SFPs, 10-Gbps SFPs, 16/32-Gbps SFP+ and QSFP+, G620 QSFP+)

#### NOTE

For loopback testing, both direct (port-to-port) optical cabling and optical loopback (by means of an optical loopback connector) are supported. External loopback tests require a loopback connector. When non-Brocade HBAs are used, refer to the manufacturer for supported hardware and additional testing details.

#### NOTE

Electrical and optical loopback tests are not supported on 8-Gbps LWL/ELWL SFPs, 10-Gbps SFPs, QSFP/QSFP+ FC16-64 ports, or ICLs.

The following steps are the fundamental parts of D\_Port testing:

1. The user configures the desired ports on either end, or both ends, of the connection. (The default D\_Port mode of a port is dynamic mode. If the user configures one end as D\_Port static mode, then the other end behaves as a D\_Port. Alternatively, the user can configure both ends as D\_Port static mode.)
2. Once both sides are configured, a basic test suite is initiated automatically when the link comes online, conducting diagnostic tests in the following order:
  - a. electrical loopback
  - b. optical loopback
  - c. link latency, distance, and power measurement
3. After the automatic test is complete, the user can view results through the CLI or a GUI and rectify issues (if any) that are reported.
4. The user can also start (and restart) the test manually to verify the link.

## D\_Port configuration modes and testing

A D\_Port can be configured in one of three modes:

- **Static** — This explicitly configures the port as a D\_Port. In this mode, the port remains a D\_Port until you explicitly remove the D\_Port configuration.

- **Dynamic** — The port is automatically set to a D\_Port based on an external request from a remote port on the other end of the connection. In this mode, the port remains a D\_Port until all the diagnostic tests are completed and the remote port reverts to normal mode. For the port to become a dynamic D\_Port, the remote port on the other end of the connection must be either a static D\_Port or an on-demand D\_Port. Dynamic D\_Port mode is supported on connections between a switch and a Host Bus Adapter (HBA), or an Access Gateway and an HBA/device, ISLs, and ICLs.

By default, a switch has the capability to support dynamic D\_Port mode. You can disable this capability by using the **configure** command, as shown in the following example.

```
switch:admin> configure
Configure...

Fabric parameters (yes, y, no, n): [no]
Virtual Channel parameters (yes, y, no, n): [no]
F-Port login parameters (yes, y, no, n): [no]
D-Port parameters (yes, y, no, n): [no] y

Dynamic D-Port (on, off): [on] off
```

#### NOTE

Changes are reflected in the RASLog.

- **On-demand** — This mode is off by default and must be enabled. The port then becomes a D\_Port as a result of an internal request or event within the local switch such as the **slotpoweroff**, **slotpoweron**, **slot insert**, **portcfgPersistentDisable** and **portcfgPersistEntenable** commands. In this mode, the port remains a D\_Port until all the diagnostic tests are completed successfully. If any of the tests fail, the port continues to remain a D\_Port. For a switch port to work as an on-demand D\_Port, the other end of the connection must support dynamic D\_Port capability. With Fabric OS 7.3.0 on switches and chassis, on-demand D\_Port mode can be configured by means of a switch-wide command, and is supported by default on switches and chassis (ISLs and ICLs). The following internal events within a switch or chassis can trigger a port to become a D\_Port:
  - **slotpoweroff** and **slotpoweron**
  - Slot or blade insert
  - **portcfgPersistentDisable** and **portcfgPersistentEnable** commands

Once on-demand D\_Port configuration is enabled on the switch and any of the on-demand triggers have been issued (such as **slotpoweroff**, **slotpoweron**, **slot insert**), then the port comes up in on-demand D\_Port mode.

If dynamic D\_Port is supported, the on-demand D\_Port forces the remote port to dynamic D\_Port mode, triggers the diagnostic tests automatically, and then changes back to normal port mode after successful completion of the tests.

By default, a switch does not support on-demand D\_Port mode. You can turn this capability on by using the **configure** command, as shown in the following example.

```
switch:admin> configure
Configure...

Fabric parameters (yes, y, no, n): [no]
Virtual Channel parameters (yes, y, no, n): [no]
F-Port login parameters (yes, y, no, n): [no]
D-Port parameters (yes, y, no, n): [no] y

Dynamic D-Port (on, off): [on]
On Demand D-Port (on, off): [off] on
```

#### NOTE

Even if the on-demand D\_Port option is enabled, if any static D\_Port configuration is enabled on a port, then that static configuration takes precedence.

The following table summarizes D\_Port test initiation modes and test start behavior.

TABLE 82 D\_Port configuration mode and nature of test

D_Port mode/nature of test		Description
<b>Mode</b>	Static	You must configure the port explicitly. Port remains a D_Port until you remove the configuration.
	Dynamic	No user configuration is required. D_Port mode is initiated by external request/event from the remote port. The remote port can either be a static or on-demand D_Port.
	On-demand	No user configuration is required. D_Port mode is initiated by internal request within the local switch. The remote port should be a dynamic D_Port.
<b>Nature of test</b>	Automatic	Test automatically starts when the port comes online.
	Manual	User starts test from the switch or Access Gateway side (using the <b>portdporttest</b> command with either the <b>--start</b> or <b>--restart</b> keyword), or from the HBA side (refer to "BCU D_Port commands" in this guide) for Brocade HBAs.

When the tests complete, the port behavior depends on the mode:

- For static D\_Ports, you must remove the D\_Port configuration at either or both ends of the link to bring up the port as a regular E\_Port or F\_Port.
- For a switch port in dynamic D\_Port mode, the port automatically reverts back to an E\_Port or an F\_Port if the port at the other end reverts to a regular port.
- For a switch in on-demand D\_Port mode, the port automatically reverts back to an E\_Port after the tests are completed successfully.
- Beginning with Fabric OS 8.0.1, the following test options are available for electrical and optical loopback tests: **-framesize**, **-nframes**, **-pattern**, **-payload**, **-time**. Both ends must be running the same release (Fabric OS 8.0.1 or later) or the test reverts to legacy behavior.
- To support 32-Gbps testing, Forward Error Correction (FEC) is enabled by default.

## General limitations and considerations for D\_Port tests

Consider the following issues when running D\_Port tests:

- The link to be tested must be marginally functional and able to carry a minimal number of frames before it can become a D\_Port link.
- D\_Port testing is useful for diagnosing marginal faults only. A complete failure of any component cannot be detected.
- D\_Port configuration is not supported on mezzanine cards.
- D\_Ports do not support a loop topology.
- D\_Port testing is not supported on adapter ports configured in CNA mode.
- Toggling the port on either side of the link restarts the test.
- On ICL ports and FC16-64 blade ports that are configured as D\_Ports, only link traffic tests can be run. Electrical loopback and optical loopback tests are not supported. A connection between a QSFP port of an FC16-64 and a core blade is not a valid connection.
- When a large number of D\_Ports are configured, the test is run on one port per blade at a time, and other ports wait until the test is completed. No test begins until the fabric is stable.
- Before running On-demand D\_Port tests on the links having Dense Wavelength Division Multiplexing (DWDM) or Course Wavelength Division Multiplexing (CWDM), you must provision the port by using the **portcfgdport** command with **-dwdm** option. Optical loopback tests are skipped for D\_Ports with DWDM.
- The D\_Port DWDM provisioning is applicable to static D\_Ports, On-demand D\_Ports, and Dynamic D\_Ports. During the configuration of the Static D\_Port using **portcfgdport --enable**, DWDM is automatically configured if the port was previously provisioned for DWDM.

- When you run a D\_Port test on the links between a FC16-64 port blade and a fixed-port switch or blade, run the test on one link at time for short distance links. If you have 100-km links, you should start the test on other links only after the 100-km link test is completed.
- In case of switch-to-Host Bus Adapter (HBA) or Access Gateway-to-HBA connections with Brocade HBA v3.2.3 or later, Brocade recommends that D\_Port tests be limited to a maximum of eight D\_Ports at once. Otherwise, there is a possibility of false alarms.
- If a remote SFP is not capable of running an optical loopback test or a QSFP is connected by means of a breakout cable to an SFP, the test is skipped with the reason "No remote SFP or chip support" .
- During a dynamic D\_Port configuration, when electrical or optical loopback testing is in progress and the switch is rebooted or there is a failover, it is possible for the ports to end up in an unsynchronized state. To clear this condition, enter the **portDportTest --debug** command on a D\_Port, an E\_Port, or both, as appropriate.
- Beginning with Fabric OS 8.0.1, on Gen 6 platforms it is possible to specify the number of transmitted frames and the duration of the test for electrical and optical loopback tests.

#### NOTE

Long-duration optical loopback tests can be run on only one port at a time. Long-duration electrical loopback tests are not supported.

- Refer to the following topics in this guide for additional specific information:
  - "8 Gbps LWL and ELWL SFP transceiver limitations for D\_Ports"
  - "High Availability limitations and considerations for D\_Ports"
  - "Access Gateway limitations and considerations for D\_Ports"
  - "Host Bus Adapter limitations and considerations for D\_Ports"

### Access Gateway limitations and considerations for D\_Ports

In addition to the items listed in "General limitations and considerations for D\_Ports," you should keep in mind the following limitations and considerations when using a D\_Ports with Access Gateways:

- D\_Ports on an Access Gateway are supported only when there is no mapping between F\_Ports and N\_Ports; this includes static mapping and preferred port mapping. In addition, device (WWN) mapping is also not retained when a D\_Port is used. If an Access Gateway port to be tested is mapped, the port mapping (including static and preferred port mapping) must be removed before the D\_Port can be used. Refer to "Saving port mappings on an Access Gateway" in this chapter.
- Access Gateway supports D\_Port dynamic mode only with HBAs. If the port on the connected HBA is configured as a D\_Port, the Access Gateway port automatically changes to D\_Port mode. Once the Access Gateway port becomes a D\_Port, the tests are run automatically, and then when the HBA becomes a normal port, the Access Gateway port also switches to normal F\_Port mode. However, Access Gateway-to-Access Gateway and Access Gateway-to-switch port connections require static configuration to become D\_Ports.
- If a pre-Fabric OS 7.3.0 static D\_Port is connected to a Fabric OS 7.3.0 and later port that is not a D\_Port, and dynamic D\_Port mode is not enabled, credit loss may happen on the non-D\_Port port.
- If a switch makes an on-demand D\_Port request to a port on an Access Gateway running a version of Fabric OS earlier than 7.3.0 that is not a D\_Port, the Access Gateway will disable the port. This restriction applies only to this combination of switch and Access Gateway.

### High Availability limitations and considerations for D\_Ports

Consider the following High Availability (HA) limitations and considerations when using D\_Ports:



- There is no HA support for D\_Port test options and results. Any information from a previous test is lost following a failover or reboot.
- During an HA failover reboot on one side of the link, the link is reinitialized and may restart the test. However, the test cannot proceed if the remote port is not ready to proceed further (the remote port may already be done with the D\_Port test and in the final state). In such a case, the test will eventually fail with a "Remote port not ready" message. Restarting the test from either side will recover the port.

## 8-Gbps LWL and ELWL SFP transceiver limitations for D\_Ports

Consider the following 8-Gbps LWL and ELWL SFP transceiver limitations when using D\_Ports:

- On these transceivers, only link traffic tests can be run. Electrical and optical loopback tests are not available on 8-Gbps SFP transceivers.
- On these transceivers, if the cable length is less than or equal to 100 meters, the length is displayed as "unknown". If the cable length is greater than 100 meters, the length is displayed accurately.

## Topology 1: ISLs

The following figure illustrates inter-switch links (ISLs) that connect multiple switches through a pair of chassis. The letter E represents E\_Ports to be configured as D\_Ports.

FIGURE 59 ISLs connecting multiple switches and chassis

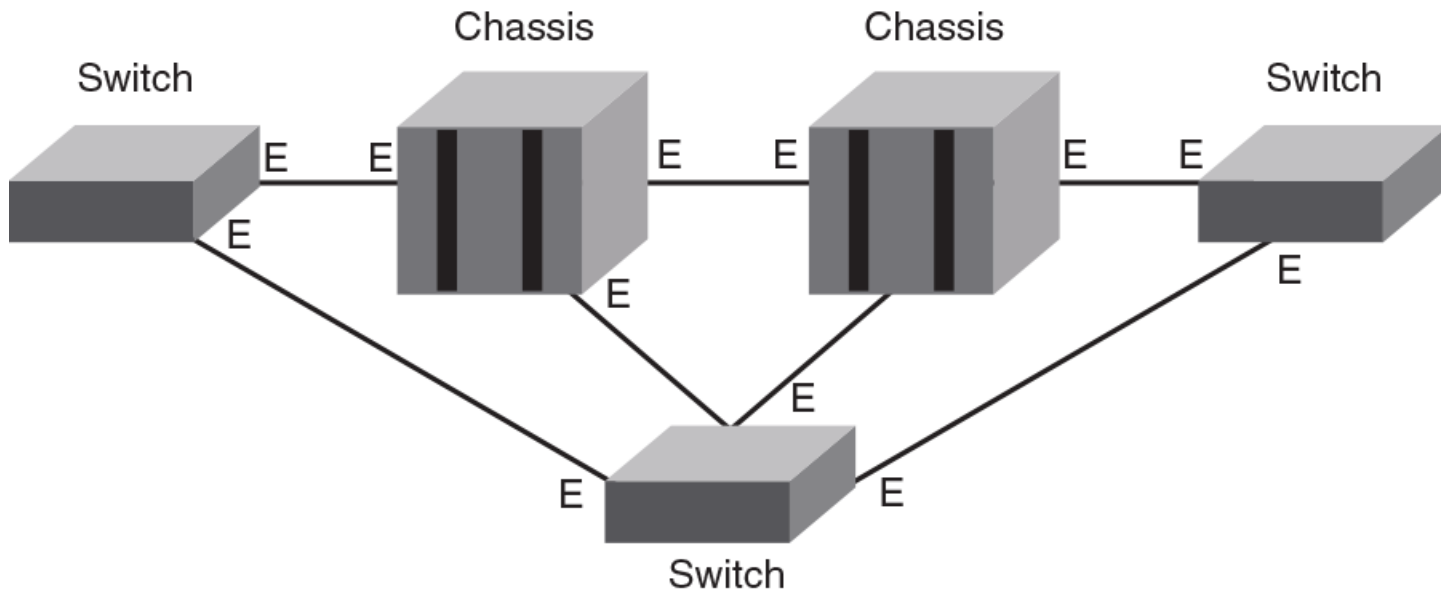

Note the following:

- Static-static, static-dynamic, and on-demand-dynamic D\_Port modes are supported on the ISLs.
- For configuration details, refer to "Using\_D\_Port\_without\_HBAs" in this chapter.

## Topology 2: ICLs

The following figure illustrates inter-chassis links (ICLs) between slots 5 and 8 in corresponding chassis. The letter E represents E\_Ports to be configured as D\_Ports.

FIGURE 60 ICLs connecting chassis blades

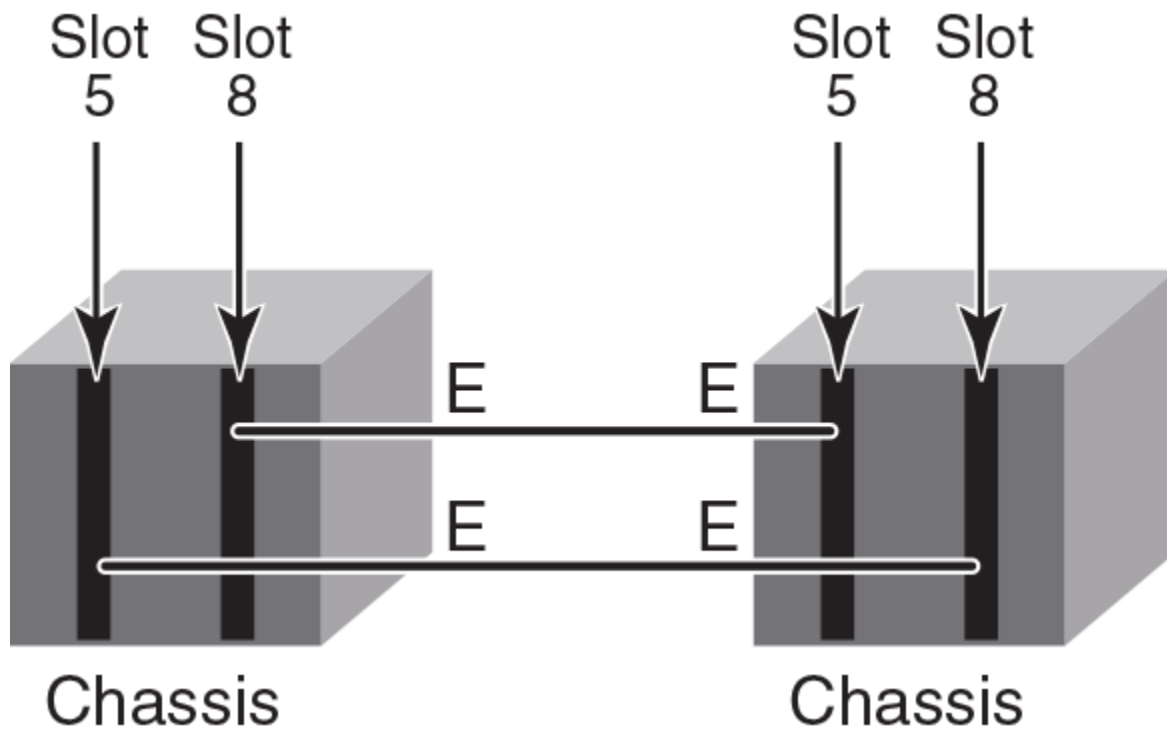

Static-static, static-dynamic, and on-demand-dynamic D\_Port modes are also supported on the ICLs.

## Topology 3: Access Gateways

The following figure illustrates a switch configured as a single Access Gateway connected to a fabric switch. The letters N and F represent, respectively, an N\_Port and an F\_Port to be configured as D\_Ports.

The Access Gateway must be a Brocade 6505 or Brocade 6510.

FIGURE 61 Single Access Gateway to switch

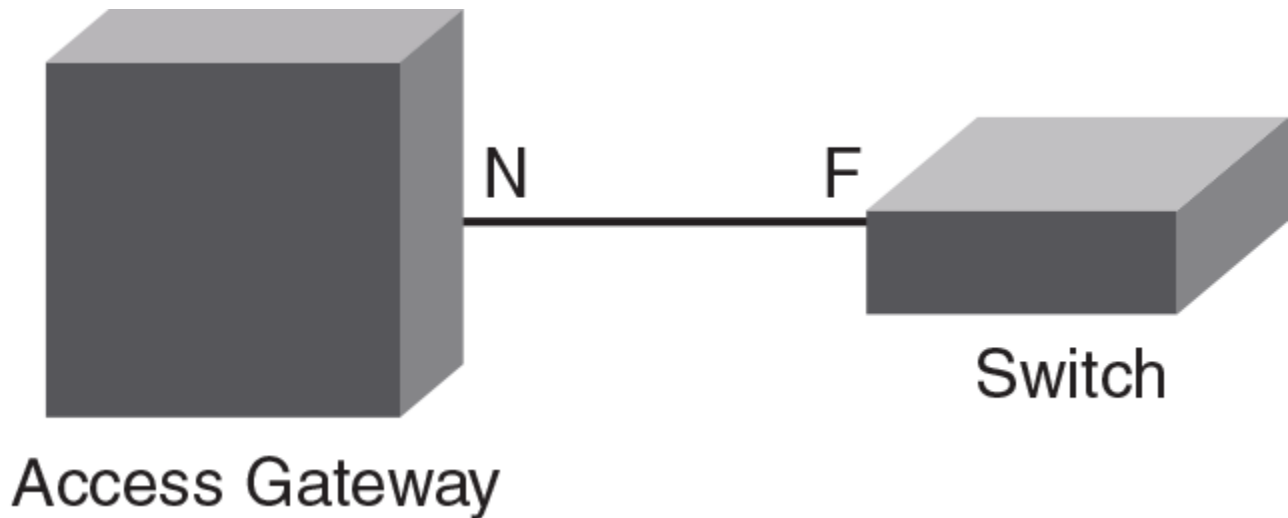

The above topology is supported only with static-static D\_Port modes.

The following figure illustrates multiple Access Gateways connected to a switch in a cascaded topology. The letters N and F represent, respectively, an N\_Port and an F\_Port to be configured as D\_Ports.

FIGURE 62 Multiple Access Gateways cascaded to switch

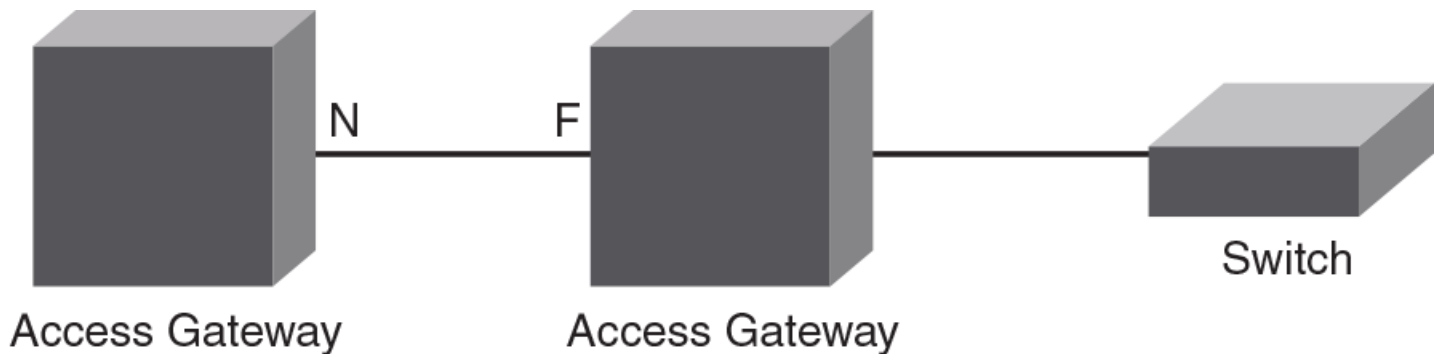

The above topology is supported only with static-static D\_Port modes.

**NOTE**

N\_Port-to-F\_Port and device (WWN) mappings must be removed from an Access Gateway port before configuring the Access Gateway port as a D\_Port. Refer to [Saving port mappings on an Access Gateway](#) on page 424.

The following figure illustrates connectivity between an HBA and an Access Gateway. The letter F represents an F\_Port to be configured as a D\_Port.

FIGURE 63 Access Gateway to HBA

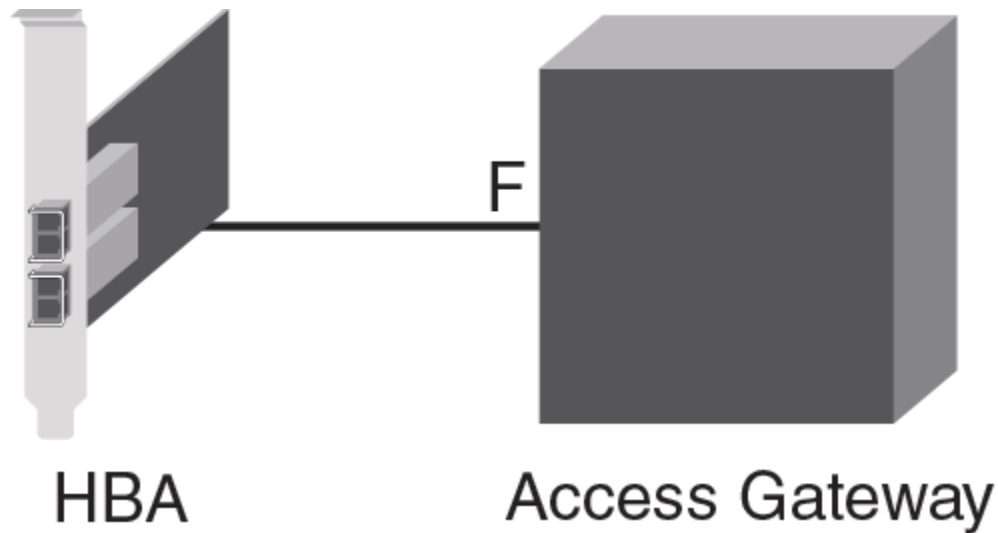

Static-static and static (HBA) - dynamic (AG) D\_Port modes are supported.

### Saving port mappings on an Access Gateway

Before configuring ports as D\_Ports on a switch configured as an Access Gateway, you must remove N\_Port-to-F\_Port and device (WWN) mappings. Fabric OS commands are available to save N\_Port mappings. Once you save them, you can display the saved N\_Port mappings to reconfigure them after D\_Port is disabled. A command is also available to delete saved N\_Port mappings.

For more details, refer to Chapter 2, "Configuring Ports in Access Gateway Mode," in the *Access Gateway Administrator's Guide*.

### Topology 4: HBA to switch

The following figure illustrates connectivity between an HBA and a switch. The letter "F" represents an F\_Port to be configured as a D\_Port. This topology supports static-static and dynamic (switch) - static (HBA) D\_Port mode. In dynamic mode, the switch port does not need to be configured explicitly as a D\_Port. It comes up in D\_Port mode when it receives a request from the remote port.

FIGURE 64 HBA to switch

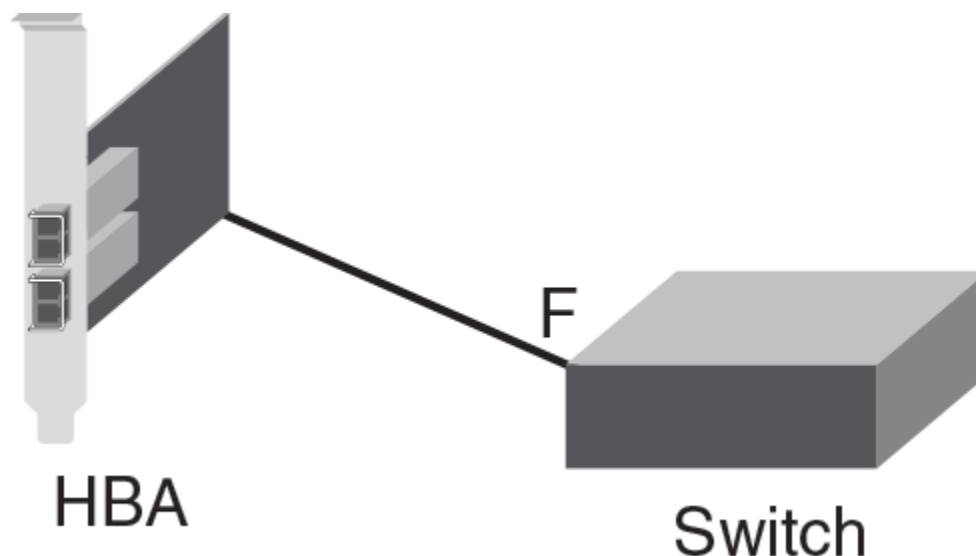

For configuration details, refer to "Using D\_Port with HBAs" in this chapter.

## Using D\_Port in static-static mode between switches

You can configure D\_Ports in static-static modes between switches (ISLs), chassis (ICLs), Access Gateways, and switch-Access Gateway links.

The sections "Enabling D\_Port" and "Disabling D\_Port" apply to topologies 1, 2, 3, and 4:

### Enabling D\_Port in static mode

Use this procedure to configure a basic, automatic D\_Port diagnostics session in static mode between two switches. The summary steps are as follows:

1. Disable ISL functionality on the ports by running the **no fabric isl enable** command.
2. Configure D\_Port static mode on both ends of the link.
3. Enable ISL functionality on the ports by running the **fabric isl enable** command.

#### ATTENTION

The automatic test might fail if you do not follow the sequence of steps exactly.

#### NOTE

"Port 1" and "Port 2" simply represent corresponding peer ports at opposite ends of the link to be tested. Switch A and Switch B can be the same platform or different platforms supporting an end-to-end D\_Port connection.

1. Disable Port 1 on Switch A.

```
switchA:admin> portdisable 1
```

- Configure Port 1 on Switch A as a D\_Port in static mode.

```
switchA:admin> portcfgdport --enable 1
```

- Repeat Step 1 and Step 2 for the corresponding port (in this example, Port 2) on Switch B.

```
switchB:admin> portdisable 2
switchB:admin> portcfgdport --enable 2
```

- Reenable Port 1 on Switch A.

```
switchA:admin> portenable 1
```

- Renable Port 2 on Switch B.

```
switchB:admin> portenable 2
```

The basic test suite starts as soon as both ports are enabled and ready to perform the test.

- While the test is running, you can enter a variety of **show** commands to confirm the D\_Port configuration and view test results on an interface. See "Using D\_Port show commands" at the end of this chapter.

To view D\_Port status and test results for an interface:

```
switch:admin> portdporttest --show 10/0/39

D-Port Information:
=====
Port:                               7
Remote WWNN:                        10:00:00:05:33:81:43:00
Remote port index:                   71
Mode:                                Automatic
No. of test frames:                  1 Million
Test frame size:                     1024 Bytes
FEC (enabled/option/active):         Yes/No/No
CR (enabled/option/active):          Yes/No/No
Start time:                          Sun Dec 7 22:49:05 2014
End time:                            Sun Dec 7 22:49:30 2014
Status:                              PASSED
=====
Test                               Start time      Result          EST (HH:MM:SS)  Comments
=====
Electrical loopback                 22:49:07        PASSED          -----
Optical loopback                    22:49:21        PASSED          -----
Link traffic test                    22:49:26        PASSED          -----
=====
Roundtrip link latency:              277 nano-seconds
Estimated cable distance:            3 meters
Buffers required:                    1 (for 2112 byte frames at 16Gbps speed)
Egress power:                        Tx: -2.6 dBm, Rx: -3.3 dBm, Diff: 0.7 dBm (Loss is within tolerable
limit)
Ingress power:                       Rx: -2.5 dBm, Tx: -2.7 dBm, Diff: 0.0 dBm (No Loss)
```

- To confirm D\_Port test results for all ports, use the following command.

```
switch:admin> portdporttest --show all

Port State   SFP Capabilities Test Result
=====
24  ONLINE  E,O          PASSED
26  ONLINE  E,O          PASSED
33  OFFLINE  ---         FAILED
```

- Optional:* To stop the test on both ends, use the **portDportTest --stop** command on both the ends. After stopping the test, verify manually that the test has stopped on both ends. You can restart the test on both ends using the **portDportTest --start/restart** command on any one of the ends. You do not need to run the same command on both ends of a single connection

## Disabling D\_Port in static mode

Use this procedure to disable a D\_Port diagnostics session in static mode, as configured in "Enabling D\_Port in static mode."

### NOTE

"Port 1" and "Port 2" simply represent corresponding peer ports at opposite ends of the link to be tested.

1. Disable Port 1 on Switch A.

```
switchA:admin> portdisable 1
```

2. Disable the D\_Port functionality in static mode on Port 1 on Switch A.

```
switchA:admin> portcfgdport --disable 1
```

3. Repeat Steps 1 and Step 2 for Port 2 on Switch B.

```
switchB:admin> portdisable 2
switchB:admin> portcfgdport --disable 2
```

4. Reenable Port 1 on Switch A.

```
switchA:admin> portenable 1
```

5. Reenable Port 2 on Switch B.

```
switchB:admin> portenable 2
```

## Disabling D\_Port globally

You can prevent D\_Port testing from running regardless of the configuration at the other end of the link.

1. Enter interface subtype configuration mode.
2. Enter the **fabric dport mode none** command.

## Using D\_Port in dynamic mode

Enabling dynamic D\_Port switch-wide configuration forces the ports on that switch or chassis to respond to D\_Port requests from the other end of the connection. It basically responds to a remote port request to change its mode to D\_Port mode, and run diagnostic tests automatically. For more information on enabling dynamic D\_Port mode for all ports in a switch or chassis, refer to "D\_Port configuration mode and testing" in this chapter.

## Preprovisioning D\_Ports

In a normal scenario, you must disable a port before configuring it as a static D\_Port. This is a disruptive operation and any command or procedure error could cause the wrong port to go down. To avoid such errors, you can preprovision a port that needs to be configured as a D\_Port. Any preprovisioned port does not require to be disabled before being configured as a D\_Port.

1. To add one or more ports to the D\_Port provision list, use the **portcfgdport --provision -add [-dwdm] [slot/]port\_list** command. If the **-dwdm** option is specified, the ports in the provision list are provisioned for D\_Ports over links with DWDM or CWDM.

With the preprovisioning of D\_Ports, links with DWDM or CWDM can support dynamic D\_Port testing and on-demand D\_Port testing.

The following example shows how to provision a port with the DWDM option.

```
Switch:admin> portcfgdport --provision -add -dwdm 7/16
```

The following example shows how to provision a port without the DWDM option.

```
Switch:admin> portcfgdport --provision -add 7/20
```

- (Optional). To remove one or more ports from the provision list, use the **portcfgdport --provision -delete [-dwdm] [slot/]port\_list** command. Specifying the **-dwdm** is optional. When a port is removed from the provision list, the D\_Port DWDM provisioning is automatically cleared.

The following example shows how to delete a port with the DWDM option.

```
Switch:admin> portcfgdport --provision -delete -dwdm 4/12
```

The following example shows how to delete a port without the DWDM option.

```
Switch:admin> portcfgdport --provision -delete 4/16
```

- To list the ports in the provision list, use the **portcfgdport --provision -show** command, as in the following example.

```
Switch:admin> portcfgdport --provision -show
Slot Port D-Port provision DWDM
=====
 3   4     ON         OFF
 3   5     ON         OFF

Switch:admin> portcfgdport --provision -show 3/2-5
Slot Port D-Port provision DWDM
=====
 3   2     OFF        OFF
 3   3     OFF        OFF
 3   4     ON         OFF
 3   5     ON         OFF
```

The following example shows a port that is not preprovisioned.

```
Switch:admin> portcfgdport --provision -show 3/2
Slot Port D-Port provision DWDM
=====
 3   2     OFF        OFF
```

- To enable D\_Port mode on a preprovisioned port, use the **portcfgdport --enable** command. You do not need to disable the port before running this command. However, this command will display an error message if the particular port is not preprovisioned using the previous steps.

Specifying **-dwdm** is optional. If the port is preprovisioned as DWDM, the port is automatically configured as DWDM.

The following example enables the port as D\_Port.

```
Switch:admin> portcfgdport --enable 4/10
```

The following example enables the port as DWDM.

```
Switch:admin> portcfgdport --enable -dwdm 5
```

- To disable D\_Port mode on a preprovisioned port, use the **portcfgdport --disable** command.

The following example disables the port as D\_Port.

```
Switch:admin> portcfgdport --disable 4/10
```



The following example disables the port as DWDM.

```
Switch:admin> portcfgdport --disable -dwdm 5
```

## Using D\_Port between switches and HBAs

When HBAs are used, D\_Port mode initiates electrical loopback, optical loopback, and link-traffic diagnostic tests on the link between the HBA and the connected switch port. Results can be viewed from the switch by means of Fabric OS commands and from the Brocade HBA by way of the Brocade Command Line Utility (BCU) and Brocade Host Connectivity Manager (HCM) during or after the test. Once in D\_Port mode, the adapter port does not participate in fabric operations, log in to a remote device, or run data traffic.

### NOTE

The syntax in this section applies to Brocade HBAs only. Where HBAs are supplied by other vendors, view the appropriate GUI or CLI interface to see the results on the HBA side, and use the commands as provided by the vendor.

In dynamic D\_Port mode, you can disable the physical port by using the **bcu port --disable** command. However, that command will not exit dynamic D\_Port mode. When you enable the port again, the switch will again force the adapter port into D\_Port mode if the switch port is still enabled as a D\_Port.

The following sections apply to "Topology 4: HBA to switch":

- "Automatic mode configuration"
- "Dynamic mode configuration"
- "BCU D\_Port commands"

## Enabling D\_Port in static mode between a switch and an HBA

This procedure enables a D\_Port diagnostic session from the connected switch to an HBA. After the default test suite is run automatically, you can run specific tests manually to obtain additional detail.

1. Disable the switch port by using the **portDisable** command.
2. Configure the switch port that you want to enable as a D\_Port by using the **portCfgDport --enable** command.
3. Disable the adapter port by using the adapter **bcu port --disable** command.
4. Enable the switch port by using the **portEnable** command.
5. Enable the adapter port as a D\_Port by using the adapter **bcu diag --dportenable** command and configure test parameters.

For more details on adapter configuration, refer to the *Brocade Adapters Administrator's Guide*.

6. Enable the switch port.

## Using non-Brocade HBAs for D\_Port testing

This section illustrates how to enable Emulex or QLogic HBA cards for D\_Port testing.

Cards must be installed in a server according to the manufacturer's instructions and connected to a Brocade switch.

Support is provided for non-Brocade HBAs beginning with Fabric OS 8.0.1 on Gen 6 platforms.

### Enabling D\_Port testing with an Emulex HBA

This task illustrates how to enable D\_Port testing with an Emulex HBA.

D\_Port testing is supported on Emulex 16G and 32G cards. For the latest firmware and product-specific details, go to [www.emulex.com](http://www.emulex.com).

1. Configure the Brocade switch into dynamic D\_Port mode as follows.
  - a) Disable the switch by entering the **switchDisable** command.

**NOTE**

Dynamic D\_Port is enabled by default.

```
switch:admin> switchdisable
```

- b) Enter the **configure** command, and then select "D-Port Parameters" and ensure that dynamic D\_port testing is enabled and on-demand port testing is disabled.

Configure...

```
Fabric parameters (yes, y, no, n): [no]
Virtual Channel parameters (yes, y, no, n): [no]
F-Port login parameters (yes, y, no, n): [no]
D-Port Parameters (yes, y, no, n): [no] y

Dynamic D-Port (on, off): on
On Demand D-Port (on, off): off
```

2. Re-enable the switch by using the **switchEnable** command.
 

```
switch:admin> switchenable
```
3. From the host server, start D\_Port testing by selecting the Emulex "OneCommand Manager."
4. For each port under test, click the **Diagnostics** tab, then click **D\_Port Tests**.

## Enabling D\_Port testing with a QLogic HBA

This task illustrates how to enable D\_Port testing with a QLogic HBA.

D\_Port testing is supported on QLogic 16G and 32G cards. For the latest firmware/driver and product-specific details, go to [www.qlogic.com](http://www.qlogic.com). If the latest firmware/driver supporting D\_Port testing is installed in the server, nothing further needs to be done on the server side.

**NOTE**

The QLogic cards support only electrical and optical loopback tests. They do not support link traffic tests.

1. On the Brocade switch, convert the port from an F\_Port to a D\_Port, disabling the specified F\_Port by entering the **portDisable** *port\_ID* command, as in the following example.

```
switch:admin> portdisable 1/1
```

2. Enter the **portCfgDport --enable** *port\_ID* command.

```
switch:admin> portcfgdport --enable 1/1
```

3. Enable the port by using the **portEnable** *port\_ID* command.

```
switch:admin> portenable 1/1
```

The D\_Port test begins automatically.

## BCU D\_Port commands

The following BCU commands can be used for D\_Port configuration and control:

**NOTE**

These commands are for Brocade HBAs only. Refer to documentation from other vendors as appropriate.

- **bcu diag --dportenable** -- Enables D\_Port on a specific port, sets the test pattern, and sets the frame count for testing.
- **bcu diag --dportdisable** -- Disables D\_Port on a specific port and sets the port back to an N\_Port or NL\_Port.
- **bcu diag --dportshow** -- Displays test results for a test in progress on a specific port.
- **bcu diag --dportstart** -- Restarts a test on a specific port when the test has completed.
- **bcu port --list** -- Displays the D\_Port enabled or disabled state on the adapter and connected switch.

## Host Bus Adapter limitations and considerations for D\_Ports

In addition to the items listed in "General limitations and considerations for D\_Ports," above, you should keep in mind the following limitations and considerations when using a D\_Port with a Host Bus Adapter (HBA):

- D\_Port is supported only on Brocade 16-Gbps HBA ports operating in HBA mode with a 16-Gbps SFP+ on Brocade 16-Gbps switches running Fabric OS 7.1 or later. In addition, the Brocade adapter must be using driver version 3.2.0 or higher.
- D\_Port is supported on non-Brocade 16-Gbps HBAs on Gen 5 platforms if (1) you have a Fabric Vision license or the combination of Fabric Watch license and Advanced Performance Monitoring license present on the switch *and* (2) the HBA vendor has implemented the Brocade HBA D\_Port support.
- D\_Port is supported on non-Brocade 32-Gbps HBAs on Gen 6 platforms if (1) you have a Fabric Vision license present on the switch.
- D\_Ports are not supported in a configuration of an HBA to another HBA (in target mode).
- D\_Ports on the HBA do not support forward error correction (FEC) and credit recovery (CR). If these features are enabled on the switch side, the HBA ignores them.
- Because of SFP electrical wrap (EWRAP) bleed-through, during the beginning of switch electrical loopback testing the HBA will receive some broken frames. This causes the port statistic error counter to increase. Examples are "CRC err", "bad EOF", and "invalid order set". Similar results occur for the optical loopback test. You should ignore these port statistics on the HBA.
- The following commands from the switch are not supported by the HBA, and the HBA will drop them:
  - **portdporttest --restart**
  - **portdporttest --setarg**
- The Qlogic HBA does not support manual D\_Port tests that are started from the switch side by means of the **portdporttest** command with suboptions (**--start**, **--setargs**, **--restart**, and so on). It supports only automatic tests when the port is configured as a D\_Port by means of the **portcfgdport --enable** command from the switch side.
- When Emulex HBAs are used, D\_Port tests can be triggered only from the Emulex HBA side only. The supported D\_Port configuration is "Switch (Dynamic D\_Port) /Emulex HBA (On-Demand D-port)". Static D\_Port configuration is not supported in this case.
- The maximum number of D\_Ports on which the tests can run simultaneously depends on the HBA firmware version.

**TABLE 83** Limitation on number of D\_Ports for simultaneous tests

HBA firmware version	Maximum number of D_Ports on which tests can be run simultaneously
HBA v3.2.0	4
HBA v3.2.3	8

- As soon as the HBA is configured as the static D\_Port, the switch changes to dynamic D\_Port mode. After the test is completed and the switch is rebooted, the switch port changes back to G\_Port mode. To resolve this issue, remove the static D\_Port configuration on the HBA.

- Powering off and on or plugging in and out slots containing ports in D\_Port mode results in those ports losing the dynamic D\_Port state when the slot or port is back up. If this happens, you must reconfigure the static D\_Port mode on the HBA.

#### NOTE

Note the following considerations applicable to 32-Gbps SFPs and QSFPs.

With the introduction of the new SFPs and QSFPs, FEC and FEC with Transmitter Training Signal (TTS) mode is enabled by default for 32 Gbps. FEC cannot be disabled in this case. The following table summarizes the state of the FEC fields and the resulting behavior.

**TABLE 84** FEC field state and behavior for 32-Gbps tests

Field	State/Behavior
Enabled	State is "Yes" if port is FEC capable and FEC is configured by means of the <b>portCfgFEC</b> command. For 32-Gbps SFP/QSFPs at link speed of 32 Gbps, FEC is enabled by default and cannot be disabled.
Option	State is "Yes" if <b>portDporttest</b> command is used with the <b>-fec</b> option. For link speed of 32 Gbps, FEC is auto enabled, irrespective of this option.
Active	State is "Yes" always for 32 Gbps alone. This depends on the capability of local and remote ports and does not depend on the <b>-fec</b> option alone.

The output of the **portdporttest --show** command displays FEC = Yes for both Enabled and Active for 32 Gbps only. The output is not changed for port speeds of 10 or 16 Gbps.

## Confirming SFP and link status with an HBA

The steps in the following example illustrate how the **bcu diag --dportenable** command will fail with an SFP installed but without a connection to the switch.

- Confirm the initial port status.

```
# bcu port --list
-----
Port#  FN  Type  PWWN/MAC                FC Addr/  Media  State    Spd
          Eth dev
-----
1/0    -   fc    10:00:8c:7c:ff:1c:e9:00  160000    sw     Linkup   16G*
        0   fc    10:00:8c:7c:ff:1c:e9:00  160000    sw     Linkup   16G*
1/1    -   fc    10:00:8c:7c:ff:1c:e9:01  --         sw     Linkdown ---
        1   fc    10:00:8c:7c:ff:1c:e9:01  --         sw     Linkdown ---
-----
```

- Disable the port.

```
# bcu port --disable 1/0
port disabled
```

- Remove the connection to the switch and attempt to enable the D\_Port.

```
# bcu diag --dportenable 1/0
ERROR: Timer expired - Retry if persists contact support
```

- Install an SFP and attempt to enable the D\_Port.

```
# bcu diag --dportenable 1/0
ERROR: Switch port is not D_Port capable or D_Port is disabled
```

- Connect to the HBA without the SFP and disable the native port.

```
# bcu port --disable 1/0
port disabled
```

- Attempt to enable the D\_Port.

```
# bcu diag --dportenable 1/0
ERROR: SFP is not present.
D-port will be enabled but it will be operational only after inserting a valid SFP.
```

## Using D\_Port in on-demand mode

Enabling on-demand D\_Port switch-wide configuration forces the ports on that switch or chassis to respond to an internal requests within the switch as a result of certain events. The switch basically responds to internal request to change a port mode to D\_Port mode, and run diagnostic tests automatically. For more information on enabling on-demand D\_Port mode for all ports in a switch or chassis, refer to "D\_Port configuration modes and nature of test," above.

When an on-demand D\_Port-capable switch or chassis comes online, the switch checks if the other end of the connection supports dynamic D\_Port mode. If dynamic D\_Port is supported on the other end, the switch changes the remote port to D\_Port mode, and then triggers diagnostic tests automatically. The D\_Ports change to normal port mode after successful completion of the tests.

## Using D\_Port show commands

This section presents a variety of options for viewing the results of D\_Port testing.

In addition to using the **portDportTest** command to start or stop D\_Port tests, you can also use it to show a variety of detailed test results.

You can display the complete results from either the responder or the initiator switch. If the initiator switch is running Fabric OS v7.1.x or earlier, the responder displays only the local D\_Port results, and you must query the initiator to see the complete results.

The following example shows basic D\_Port results for a specified port.

```
switch:admin> portdporttest --show 26
D-Port Information:
=====
Port:                26
Remote WWNN:         10:00:00:05:33:13:2f:b5
Remote port index:   42
Mode:                Automatic
Start time:          Wed Feb  2 01:41:43 2011
End time:            Wed Feb  2 01:43:23 2011
Status:              PASSED
=====
Test                  Start time   Result      EST (secs)  Comments
=====
Electrical loopback   01:42:08    PASSED     --          -----
Optical loopback      01:42:16    PASSED     --          -----
Link traffic test     01:43:15    PASSED     --          -----
=====
Roundtrip link latency:      1108 nano-seconds
Estimated cable distance:    20 meters
Buffers required:                                1 (for 1024 byte frames at 16Gbps
speed)
Egress power:                Tx:-3.3 dBm, Rx:-3.7 dBm, Loss:0.4 dB (within tolerable
limits)
Ingress power:               Rx:-3.5 dBm, Tx:-3.2 dBm, Loss:0.3 dB (within tolerable
limits)
```

The following example shows the `portdporttest --show` output where the electrical and optical tests pass but the link traffic test fails.

```
switch:admin> portdporttest --show 26
D-Port Information:
=====
Port:          26
Remote WWNN:   10:00:00:05:33:13:2f:b5
Remote port index: 42
Mode:         Automatic
Start time:   Wed Feb  2 01:41:43 2011
End time:     Wed Feb  2 01:43:23 2011
Status:       PASSED
=====
Test           Start time  Result      EST (secs)  Comments
=====
Electrical loopback 01:42:08   PASSED     --          -----
Optical loopback   01:42:16   PASSED     --          -----
Link traffic test  01:43:15   FAILED     --          -----
=====
Roundtrip link latency:      1108 nano-seconds
Estimated cable distance:    20 meters
Buffers required:            1 (for 1024 byte frames at 16Gbps speed)
Egress power:                Tx:-3.3 dBm, Rx: Not Avail
Ingress power:               Rx:-3.5 dBm, Tx: Not Avail
```

Use the `portDportTest --show all` command to display the capabilities and test results of all the D\_Ports in a switch.

```
switch:admin> portdporttest --show all
Port State      SFP Capabilities  Test Result
=====
24  ONLINE      E,O              PASSED
26  ONLINE      E,O              FAILED
33  ONLINE      E,O              PASSED
```

Use the `switchShow` command to see detailed switch and D\_Port information.

```
switch:admin> switchshow
switchName:      switch_10
switchType:      109.1
switchState:     Online
switchMode:      Native
switchRole:      Principal
switchDomain:     1
switchId:        fffc01
switchWwn:       10:00:00:05:33:13:2f:b4
zoning:          OFF
switchBeacon:    OFF
FC Router:       OFF
Allow XISL Use:  ON
LS Attributes:   [FID: 10, Base Switch: No, Default Switch: No, Address Mode 0]
Index Port Address Media Speed State  Proto
=====
 24 24  010000  id   N16  Online  FC  D-Port Loopback->Port 24
 26 26  010200  id   N16  Online  FC  D-Port segmented, (D-Port mode mismatch)
 33 33  010300  id   N8   Online  FC  D-Port 10:00:00:05:33:13:2f:b5
```

The following example illustrates D\_Port test output at 32-Gbps.

```
switch:admin> portdporttest --show 2
D-Port Information:
=====
Port:          2
Remote WWNN:   10:00:00:27:f8:f0:26:40
Remote port index: 0
Mode:         Manual
No. of test frames: 1 Million
Test frame size: 1024 Bytes
FEC (enabled/option/active): Yes/No/Yes
CR (enabled/option/active): No/No/No
Start time:   Tue Jun 23 07:27:43 2015
```

```

End time:                Tue Jun 23 07:28:15 2015
Status:                  PASSED
=====
Test                     Start time           Result               EST(HH:MM:SS)       Comments
=====
Electrical loopback      07:27:45            PASSED              -----             -----
Optical loopback         07:28:04            PASSED              -----             -----
Link traffic test        07:28:10            PASSED              -----             -----
=====
Roundtrip link latency:   272 nano-seconds
Estimated cable distance: 2 meters
Buffers required:        1 (for 2112 byte frames at 32gbps speed)
Egress power:            Tx: 0.3 dBm, Rx: -3.6 dBm, Diff: 3.9 dBm (Loss is within tolerable limit)
Ingress power:           Rx: -4.1 dBm, Tx: 0.3 dBm, Diff: 4.4 dBm (Loss is within tolerable limit)

```

The following example illustrates D\_Port test output for longer test duration.

```

BB1_SW6520_135190:FID128:root> portdporttest --show 31
D-Port Information:
=====
Port:                    31
Remote WNN:              10:00:50:eb:1a:0d:be:08
Remote port index:       31 (External loopback)
Mode:                    Manual
Test Duration (HH:MM):   00:01
Test frame size:         1024 Bytes
FEC (enabled/option/active): Yes/No/No
CR (enabled/option/active): Yes/No/No
Start time:              Fri Apr 15 05:14:20 2016
End time:                -----
Status:                  IN PROGRESS
=====
Test                     Start time           Result               EST(HH:MM:SS)       Comments
=====
Electrical loopback      05:14:22            PASSED              -----             -----
Optical loopback         05:14:37            IN PROGRESS         00:01:00            -----
Link traffic test        -----             NOT STARTED         -----             -----
=====
Roundtrip link latency:   148 nano-seconds
Estimated cable distance: 0 meters
Egress power:            Tx: -2.9 dBm, Rx: Not Avail.
Ingress power:           Rx: -2.8 dBm, Tx: Not Avail.

```

Use the **portCfgShow** command to see which ports are D\_Port-enabled.

```

switch:admin> portcfgshow
Ports of Slot 0          24  26  27
-----+-----+-----
Octet Speed Combo      1   1   1
Speed                  AN  AN  AN
AL_PA Offset 13        ..  ..  ..
Trunk Port              ON  ON  ON
Long Distance          ..  ..  ..
.....
.....
Port Auto Disable      ..  ..  ..
CSCTL mode             ..  ..  ..
D-Port mode            ON  ON  ON
D-Port over DWDM       ..  ..  ..
Compression            ..  ..  ..
Encryption             ..  ..  ..
FEC                    ON  ON  ON
Fault Delay            0   0   0
  where AE:QoSAutoEnable, AN:AutoNegotiate, ..:OFF, -:NotApplicable, ?:INVALID

```





# NPIV

- [NPIV overview](#).....437
- [Configuring NPIV](#).....438
- [Enabling and disabling NPIV](#).....439
- [Base device logout](#).....440
- [Viewing NPIV port configuration information](#).....443

## NPIV overview

N\_Port ID Virtualization (NPIV) enables a single Fibre Channel protocol port to appear as multiple, distinct ports, providing separate port identification within the fabric for each operating system image behind the port (as if each operating system image had its own unique physical port). NPIV assigns a different virtual port ID to each Fibre Channel protocol device. NPIV is designed to enable you to allocate virtual addresses without affecting your existing hardware implementation. The virtual port has the same properties as an N\_Port, and is therefore capable of registering with all services of the fabric. This chapter does not discuss the Access Gateway feature. For more information on the Access Gateway feature, refer to the *Access Gateway Administrator's Guide*.

Each NPIV device has a unique device PID, Port WWN, and Node WWN, and behaves the same as all other physical devices in the fabric. In other words, multiple virtual devices emulated by NPIV appear no different than regular devices connected to a non-NPIV port.

The same zoning rules apply to NPIV devices as non-NPIV devices. Zones can be defined by *domain,port* notation, by WWN-based zoning, or both. However, to perform zoning to the granularity of the virtual N\_Port IDs, you must use WWN-based zoning.

If you are using *domain,port* zoning for an NPIV port, and all the virtual PIDs associated with the port are included in the zone, then a port login (PLOGI) to a non-existent virtual PID is not blocked by the switch; rather, it is delivered to the device attached to the NPIV port. In cases where the device is not capable of handling such unexpected PLOGIs, use WWN-based zoning.

The following example shows the number of NPIV devices in the output of the **switchShow** command. The number of NPIV devices is equal to the sum of the base port plus the number of NPIV public devices. The base port is the N\_Port listed in the **switchShow** output. Based on the formula, index 010000 shows only 1 NPIV device and index 010300 shows a total of 222 NPIV devices (one N\_Port FLOGI device and 221 NPIV devices).

```
switch:admin> switchshow
switchName:      5100
switchType:      71.2
switchState:     Online
switchMode:      Access Gateway Mode
switchWwn:       10:00:00:05:1e:41:49:3d
switchBeacon:    OFF
Index Port Address Media Speed State Proto
=====
0 0 010000 id N4 Online FC F-Port 20:0c:00:05:1e:05:de:e4 0xa06601
1 1 010100 id N4 Online FC F-Port 1 N Port + 4 NPIV public
2 2 010200 id N4 Online FC F-Port 1 N Port + 119 NPIV public
3 3 010300 id N4 Online FC F-Port 1 N Port + 221 NPIV public
```

### NOTE

When an Access Gateway is connected to the switch, the Access Gateway is counted as the base device or base login and it is not included in the NPIV device count.

## Upgrade considerations

The maximum logins per switch decreased with Fabric OS v6.4.0. When upgrading from a release previous to Fabric OS v6.4.0, the configured maximum is carried forward and may exceed the Fabric OS v6.4.0 limit. It is recommended to reconfigure this parameter to be within the range permitted in Fabric OS v6.4.0 and later.

## Fixed addressing mode

Fixed addressing mode is the default addressing mode used in all platforms that do not have Virtual Fabrics enabled.

The number of NPIV devices supported on shared area ports (48-port blades) is reduced to 64 from 128 when Virtual Fabrics mode is enabled.

## 10-bit addressing mode

The 10-bit addressing mode is the default mode for all the logical switches created in the Brocade DCX 8510, and X6 Backbones. The number of NPIV supported on a port is 64.

In 10-bit addressing mode, the switch can dynamically assign up to 112, 8-bit areas, after that 10-bit areas are assigned. So the 8-bit areas can have up to 255 devices, and 10-bit areas can have up to 63 devices.

The following table shows the number of NPIV devices supported on the Brocade DCX 8510, and X6 Backbones.

**TABLE 85** Number of supported NPIV devices per port

Platform	Virtual Fabrics	Logical switch type	NPIV support
DCX 8510-8 (or) X6-8	Disabled	N/A	Yes, 127 virtual device limit.
DCX 8510-8 (or) X6-8	Enabled	Default switch	Yes, 63 virtual device limit.
DCX 8510-8 (or) X6-8	Enabled	Logical switch	Yes, 255 virtual device limit.  The first 112 physical NPIV-capable devices connected to a logical switch using 10-bit addressing can log in 255 logical devices. The physical NPIV-capable devices after 112, 113, and higher, are limited to 63 logical devices. If port is assigned a 10-bit area, the number of NPIV devices supported is 63.
DCX 8510-8 (or) X6-8	Enabled	Base switch	No.
DCX 8510-4 (or) X6-4	Disabled	N/A	Yes, 255 virtual device limit.
DCX 8510-4 (or) X6-4	Enabled	Default switch	Yes, 255 virtual device limit.
DCX 8510-4 (or) X6-4	Enabled	Logical switch	Yes, 255 virtual device limit.  If port is assigned a 10-bit area, the number of NPIV devices supported is 63.
DCX 8510-4 (or) X6-4	Enabled	Base switch	No.

## Configuring NPIV

The NPIV feature is enabled by default. You can set the number of virtual N\_Port IDs per port to a value from 1 through 255 per port. The default setting is 126.

The **portCfgNPIVPort** command is used to specify the maximum number of virtual N\_port IDs per port on a switch. It can also be used to enable or disable NPIV. Once NPIV is enabled on the port, you can specify the number of logins per port. If the NPIV feature has been disabled, then the NPIV port configuration does not work.

The addressing mode can limit the maximum number of NPIV logins to 127 or 63 depending on the mode. The **portCfgNPIVPort** command can set the maximum number of NPIV logins limit to anything from 1 through 255, regardless of the addressing mode.

Whichever of these two (addressing mode or the value configured through `portCfgNPIVPort`) is lower will be the maximum number that can be logged in.



#### CAUTION

The `portDisable` command disables the port and stops all traffic flowing to and from the port. Use this command during a scheduled maintenance.

1. Connect to the switch and log in using an account assigned to the admin role.
2. Enter the `portDisable` command.
3. Enter the `portCfgNPIVPort --setloginlimit` command with the port number and the number of logins per port.
4. Enter the `portEnable` command to enable the port.

```
switch:admin> portcfgnpivport --setloginlimit 7/0 128
NPIV Limit Set to 128 for Port 128
switch:admin> portcfgshow 7/0
Area Number:                128
Octet Speed Combo:          1(16G|8G|4G|2G)
Speed Level:                 AUTO(SW)
AL_PA Offset 13:            OFF
Trunk Port                   ON
Long Distance                OFF
VC Link Init                 OFF
Locked L_Port                OFF
Locked G_Port                OFF
Disabled E_Port              OFF
Locked E_Port                OFF
ISL R_RDY Mode               OFF
RSCN Suppressed              OFF
Persistent Disable           OFF
LOS TOV enable               OFF
NPIV capability              ON
QOS E_Port                   AE
Port Auto Disable:           OFF
Rate Limit                   OFF
EX Port                      OFF
Mirror Port                  OFF
Credit Recovery              ON
F_Port Buffers               OFF
Fault Delay:                 0(R_A_TOV)
NPIV PP Limit:               128
CSCCTL mode:                 OFF
Frame Shooter Port           OFF
D-Port mode:                 OFF
D-Port over DWDM             ..
Compression:                 OFF
Encryption:                  OFF
FEC:                          ON
```

## Enabling and disabling NPIV

NPIV is enabled for every port.

#### NOTE

NPIV is a requirement for FCoE.

1. Connect to the switch and log in using an account assigned to the admin role.
2. To enable or disable NPIV on a port, enter the `portCfgNPIVPort` command with either the `--enable` or `--disable` option.

The following example shows NPIV being enabled on port 10 of a Brocade 5100:

```
switch:admin> portCfgNPIVPort --enable 10
```

**NOTE**

If the NPIV feature is disabled, the port is toggled if NPIV devices are logged in from that F\_Port (a true NPIV port). Otherwise, the firmware considers that port as an F\_Port even though the NPIV feature was enabled.

## Base device logout

Base device logout is a Fibre Channel - Lin Service 2 (FC-LS2) standard-based feature in which the Fabric OS firmware allows NPIV devices to remain logged in after the base device logs out. This feature is available on all the switches and Access Gateways starting with Fabric OS 7.3.0. Any device attached to an NPIV port is able to log in and log out without affecting the login status of the other devices on the port. This section explains the changes in F-port behavior, use case scenarios including possible changes in existing Fabric OS show commands, new CLIs and configuration commands associated with this feature. This section explains also the possible risks, compatibility (FW upgrade/downgrade) and HA aspects of Fabric OS related to this feature.

From their inception, Brocade switches have treated a base device logout on a given port as a logout of all devices on that port. For NPIV devices, this means that each NPIV device is logged out when the base device is logged out. This is referred to as the legacy functionality. When the final FC-LS2 standard was released, the functionality it defined had changed from the initial understanding. Instead of the base device logout causing all NPIV devices to log out, the base device logout affects only the base device; the NPIV devices stay logged in.

## Difference in the device logout behaviors

A base device is a device on an F\_Port that has the base PID. The base device logs in with a FLOGI. An NPIV device is a device on an F\_Port which has an NPIV PID. An NPIV device logs in with an FDISC.

The following table summarizes the difference in the base and NPIV device logout behaviors with and without the base device logout feature enabled.

**TABLE 86** Base and NPIV logout behaviors

Scenario	Without base device logout enabled	With base device logout enabled
<ul style="list-style-type: none"> <li>No device is logged in.</li> </ul>	<ul style="list-style-type: none"> <li>Requires a device with a base PID to log in to the F_Port before any NPIV device can log in.</li> </ul>	<ul style="list-style-type: none"> <li>Requires a device with a base PID to log in to the F_Port before any NPIV device can log in.</li> </ul>
<ul style="list-style-type: none"> <li>Base device is logged in.</li> </ul>	<ul style="list-style-type: none"> <li>Allows NPIV devices to log in and log out.</li> <li>Permanent Port Name (PPN) is assigned with PWWN of the base device for all the devices logged-in on that port (for both base and NPIV devices).</li> </ul>	<ul style="list-style-type: none"> <li>Allows NPIV devices to log in and log out.</li> <li>Permanent Port Name (PPN) is assigned according to FC-GS-6 (5.2.3.13) standard.</li> </ul>
<ul style="list-style-type: none"> <li>Base device is logged in.</li> <li>At least one NPIV device is logged in.</li> </ul>	<ul style="list-style-type: none"> <li>If the base device is logged out, then all the NPIV devices are also logged out.</li> <li>Removes routing information when the base device logs out.</li> </ul>	<ul style="list-style-type: none"> <li>Allows base device to log out while NPIV devices are still logged in. Indicates that the base device is logged out in the <b>switchShow</b> command output.</li> <li>Does not remove the routing information.</li> </ul>
<ul style="list-style-type: none"> <li>Base device is logged out.</li> <li>At least one NPIV device is logged in.</li> </ul>	N/A	<ul style="list-style-type: none"> <li>Allows base device to log back in as a base or NPIV device.</li> <li>Allows NPIV devices to log in and log out.</li> <li>Does not remove the routing information.</li> </ul>
<ul style="list-style-type: none"> <li>Base device is logged out.</li> <li>All NPIV devices are also logged out.</li> </ul>	<ul style="list-style-type: none"> <li>Requires a device with a base PID to log in to the F_Port before any NPIV device can log in.</li> </ul>	<ul style="list-style-type: none"> <li>Removes all the routing information.</li> <li>Requires a device with a base PID to log in to the F_Port before any NPIV device can log in.</li> </ul>

## Enabling base device logout

Both the active and the standby switches/AGs should be upgraded to Fabric OS 7.3.0 or later.

The purpose of this feature is to make it possible for all devices; including base device and NPIV devices on a NPIV port to logout and login without disrupting the remaining logged on devices. By default, the base device logout option is disabled in all the ports.

1. Enable NPIV on the required ports.  
Ports that do not have NPIV capability cannot have the base device logout option enabled.
2. Disable the ports for which you want to enable base device logout, as this is a disruptive operation.
3. Enable base device logout using the **portCfgFLOGILogout** command.

The following example enables base device logout on all the ports in the logical switch.

```
portcfgflogilogout --enable -all
```

The following example enables base device logout on only specific ports in the logical switch.

```
portcfgflogilogout --disable 7/1-5
```

## Use cases and dependencies

The following use cases and dependencies apply to the base device logout feature:

- When the base device logs out, the remaining NPIV devices on that port remain logged in.
- The base device can log in again later on the same port as the base device with a FLOGI. However, all the existing NPIV devices will be dropped and only the new FLOGI information will be retained.
- The base device can log in again later on the same port with the same PWWN, but as an NPIV device. At this point, it is no longer referred to as the base device, and it becomes a logged-in NPIV device.
- NPIV devices can log in or log out on the same port as long as at least one device (either a base device or an NPIV device) remains logged in on the port.
- The logged-out base device can log in on a different port as either the base device (with a FLOGI) or as an NPIV device (with an FDISC). If the base device logs in on a different port as a base device, it no longer is the base device for the remaining NPIV devices on the original port.
- The logged-out base device can log in to a port on a different switch as either the base device (with a FLOGI) or as an NPIV device (with an FDISC). If the base device logs in to a port on a different switch as a base device, it is no longer the base device for the remaining NPIV devices on the original port.
- When all devices (base device and NPIV devices) have logged out of a port, a base device must be the next device to log in on that port with a FLOGI.
- In Fabric OS prior to v7.3.0, the details of devices logged in with FLOGI (base devices) with AL\_PA 0x40 and 0xC0 are not propagated to NS or FCP unless the devices are registered with NS. Since they cannot be probed, devices with these AL\_PAs must initiate NS registration. If they do register with NS and then later logout, there can be multiple LUNs losing access during login time because the logged out base device entry is not removed from NS. Furthermore, the logged out base device cannot login to the fabric again. Fabric OS v7.3.0 and later provides the ability to update NS entries when these base devices perform logout. You can turn on this update mode to ensure NS and login database consistency using the "F-port Device Update Mode" option under the "Fabric parameters" section of the configure CLI. This option can only be changed when a switch is disabled. After enabling this option, all other changes for this feature are completely transparent except minor changes in **fcProbeShow** output. In other words, the firmware treats all the base devices (AL\_PAs 0x00, 0x40, 0x80, 0xC0) in the same way.
- The base device logout feature is backward compatible when you do not enable base device logout for the port.

- Default switch behavior is the legacy functionality (base device logout is disabled).
- All checks for duplicate WWN remain valid.
- The base device logout feature can coexist with other switches that do not have base device logout enabled, even if they are in the same fabric.
- Any port-related Fabric OS features that depend on the base device cannot work when the base device logs out. One example of this is device probing.
- Trunking is not affected by base device logout because only Brocade switches utilize F\_Port trunking, and the related Access Gateway N\_Ports do not keep NPIV devices logged in when the base device logs out.
- QoS, FEC, and credit recovery features are not affected by base device logout.
- Port swap is not affected by the base device logout feature.
- Connectivity to NPIV devices is not affected when the base device logs out.
- Base device logout is not supported on ICL, VE/GE (E/Ex/LG) ports.
- Base device logout must be disabled on all the ports before downgrading from Fabric OS 7.3.0 to an earlier version.

## Viewing base device logout setting

The following **portCfgShow** command output shows ON if the base device logout option is enabled, and a "." if it is disabled:

Ports of Slot 1	0	1	2	3	4	5	6	7	8	9	10	11	12	13	14	15
Speed	AN	AN	AN	AN	AN	AN	AN	AN	AN	AN	AN	AN	AN	AN	AN	AN
Fill Word(On Active)	0	0	0	0	0	0	0	0	0	0	0	0	0	0	0	0
Fill Word(Current)	0	0	0	0	0	0	0	0	0	0	0	0	0	0	0	0
AL_PA Offset 13	..	..	..	..	..	..	..	..	..	..	..	..	..	..	..	..
Trunk Port	ON	ON	ON	ON	ON	ON	ON	ON	ON	ON	ON	ON	ON	ON	ON	ON
Long Distance	..	..	..	..	..	..	..	..	..	..	..	..	..	..	..	..
VC Link Init	..	..	..	..	..	..	..	..	..	..	..	..	..	..	..	..
Locked L_Port	..	..	..	..	..	..	..	..	..	..	..	..	..	..	..	..
Locked G_Port	..	..	..	..	..	..	..	..	..	..	..	..	..	..	..	..
Disabled E_Port	..	..	..	..	..	..	..	..	..	..	..	..	..	..	..	..
Locked E_Port	..	..	..	..	..	..	..	..	..	..	..	..	..	..	..	..
ISL R_RDY Mode	..	..	..	..	..	..	..	..	..	..	..	..	..	..	..	..
RSCN Suppressed	..	..	..	..	..	..	..	..	..	..	..	..	..	..	..	..
Persistent Disable	..	..	..	..	..	..	..	..	..	..	..	..	..	..	..	..
LOS TOV enable	..	..	..	..	..	..	..	..	..	..	..	..	..	..	..	..
NPIV capability	ON	ON	ON	ON	ON	ON	ON	ON	ON	ON	ON	ON	ON	ON	ON	ON
NPIV PP Limit	126	126	126	126	126	126	126	126	126	126	126	126	126	126	126	126
NPIV FLOGI Logout	ON	ON	ON	..	ON	ON	ON	ON	ON	ON	ON	ON	ON	ON	ON	ON
QOS E_Port	AE	AE	AE	AE	AE	AE	AE	AE	AE	AE	AE	AE	AE	AE	AE	AE
EX Port	..	..	..	..	..	..	..	..	..	..	..	..	..	..	..	..
Mirror Port	..	..	..	..	..	..	..	..	..	..	..	..	..	..	..	..
Rate Limit	..	..	..	..	..	..	..	..	..	..	..	..	..	..	..	..
Credit Recovery	ON	ON	ON	ON	ON	ON	ON	ON	ON	ON	ON	ON	ON	ON	ON	ON
Fport Buffers	..	..	..	..	..	..	..	..	..	..	..	..	..	..	..	..
Port Auto Disable	..	..	..	..	..	..	..	..	..	..	..	..	..	..	..	..
CSCTL mode	..	..	..	..	..	..	..	..	..	..	..	..	..	..	..	..
D-Port mode	..	..	..	..	..	..	..	..	..	..	..	..	..	..	..	..
Fault Delay	0	0	0	0	0	0	0	0	0	0	0	0	0	0	0	0

The **switchshow** command displays the number of base devices as "1" and the number of NPIV devices. If the base device is logged out, the output displays only the number of NPIV devices.

When base device logout is enabled and the base device has logged out, the **portshow** command output displays a *FLOGI\_LOGO* with other port flags, and the PWWNs of the NPIV devices.

When base device is logged out, the **agShow**, **fdmiShow**, and **nsShow** commands do not list the base device information.

## Viewing NPIV port configuration information

Fabric OS allows you to see N\_Port ID Virtualization (NPIV) port configuration information using the **portcfgshow** and **switchshow** commands.

1. Connect to the switch and log in using an account assigned to the admin role.
2. Enter **portcfgshow** to view the switch ports information.

The following example shows whether a port is configured for NPIV:

```
switch:admin> portcfgshow

Ports of Slot 0  0  1  2  3  4  5  6  7  8  9 10 11 12 13 14 15
-----+-----+-----+-----+-----+-----+-----+-----+-----+-----+-----+-----+-----+-----+-----+-----+-----+
Speed           AN AN AN AN AN AN AN AN AN AN AN AN AN AN AN AN AN
Trunk Port      ON ON ON ON ON ON ON ON ON ON ON ON ON ON ON ON ON
Long Distance   .. .. .. .. .. .. .. .. .. .. .. .. .. .. .. .. ..
VC Link Init    .. .. .. .. .. .. .. .. .. .. .. .. .. .. .. .. ..
Locked L_Port   .. .. .. .. .. .. .. .. .. .. .. .. .. .. .. .. ..
Locked G_Port   .. .. .. .. .. .. .. .. .. .. .. .. .. .. .. .. ..
Disabled E_Port .. .. .. .. .. .. .. .. .. .. .. .. .. .. .. .. ..
ISL R_RDY Mode  .. .. .. .. .. .. .. .. .. .. .. .. .. .. .. .. ..
RSCN Suppressed .. .. .. .. .. .. .. .. .. .. .. .. .. .. .. .. ..
Persistent Disable.. .. .. .. .. .. .. .. .. .. .. .. .. .. .. .. ..
NPIV capability ON ON ON ON ON ON ON ON ON ON ON ON ON ON ON ON ON
```

3. Enter **switchshow** to view NPIV information for a given port.

If a port is an F\_Port, and you enter **switchshow**, then the port WWN of the N\_Port is returned. For an NPIV F\_Port, there are multiple N\_Ports, each with a different port WWN. The **switchshow** command output indicates whether or not a port is an NPIV F\_Port, and identifies the number of virtual N\_Ports behind it.

The following example displays the typical output from the **switchshow** command.

```
switch:admin> switchshow

switchName:      switch
switchType:      66.1
switchState:     Online
switchMode:      Native
switchRole:      Principal
switchDomain:     1
switchId:        fffc01
switchWwn:       10:00:00:05:1e:82:3c:2a
zoning:          OFF
switchBeacon:    OFF
FC Router:       OFF
FC Router BB Fabric ID: 128
Area Port Media Speed State      Proto
=====
  0  0  id  N1  Online      F-Port  1 Nport + 1 NPIV devices.
  1  1  id  N4  No_Light
  2  2  id  N4  Online      F-Port  20:0e:00:05:1e:0a:16:59
  3  3  id  N4  No_Light
  4  4  id  N4  No_Light
(output truncated)
```

4. Use the **portshow port\_number** command to view the NPIV attributes and all the N\_Port (physical and virtual) port WWNs that are listed under "portWwn" for connected device(s).

The following example displays the typical output for this command.

```
switch:admin> portshow 2

portName: 02
portHealth: HEALTHY
Authentication: None
```

```

portDisableReason: None
portCFlags: 0x1
portFlags: 0x24b03      PRESENT ACTIVE F_PORT G_PORT NPIV LOGICAL_ONLINE LOGIN NOELP LED ACCEPT
portType: 10.0
portState: 1      Online
portPhys: 6      In_Sync
portScn: 32      F_Port
port generation number: 148
portId: 630200
portIfId: 43020005
portWwn: 20:02:00:05:1e:35:37:40
portWwn of device(s) connected:
  c0:50:76:ff:fb:00:16:fc
  c0:50:76:ff:fb:00:16:f8
  ...
(output truncated)
  ...
  c0:50:76:ff:fb:00:16:80
  50:05:07:64:01:a0:73:b8
Distance: normal
portSpeed: N2Gbps
Interrupts:      0          Link_failure: 16          Frjt:      0
Unknown:        0          Loss_of_sync: 422         Fbsy:      0
Lli:            294803     Loss_of_sig: 808
Proc_rqrd:      0          Protocol_err: 0
Timed_out:      0          Invalid_word: 0
Rx_flushed:     0          Invalid_crc: 0
Tx_unavail:     0          Delim_err: 0
Free_buffer:    0          Address_err: 1458
Overrun:        0          Lr_in: 15
Suspended:      0          Lr_out: 17
Parity_err:     0          Ols_in: 16
2_parity_err:   0          Ols_out: 15
CMI_bus_err:    0

```

## Viewing virtual PID login information

Use the **portLoginShow** command to display the login information for the virtual PIDs of a port. The following example is sample output from the **portLoginShow** command:

```

switch:admin> portloginshow 2
Type PID      World Wide Name      credit df_sz cos
=====
fe 630240 c0:50:76:ff:fb:00:16:fc 101 2048 c scr=3
fe 63023f c0:50:76:ff:fb:00:16:f8 101 2048 c scr=3
fe 63023e c0:50:76:ff:fb:00:17:ec 101 2048 c scr=3
...
<output truncated>
...
ff 630202 c0:50:76:ff:fb:00:17:70 192 2048 c d_id=FFFFFFC
ff 630201 c0:50:76:ff:fb:00:16:80 192 2048 c d_id=FFFFFFC

```

To view the details of the devices that were last logged in to a particular port, you can use the **history** option in the **portLoginShow** command. The device details such as type, PID and WWN along with the logged out timestamp in UTC format will be displayed.

```

Pluto:root> portloginshow 1/0 -history
Type PID      World Wide Name      logout time
=====
fd 550002 30:0c:02:05:1e:61:23:8f 09/17/2014 13:56:01
fd 550001 30:0c:01:05:1e:61:23:8f 09/17/2014 13:56:02
fe 550000 30:0c:00:05:1e:61:23:8f 09/17/2014 13:56:02
fd 550001 30:0c:01:05:1e:61:23:8f 09/18/2014 05:49:37
Pluto:root>

```



# Fabric-Assigned PWWN

---

• Fabric-Assigned PWWN overview.....	445
• User- and auto-assigned FA-PWWN behavior .....	446
• Configuring an FA-PWWN for an HBA connected to an Access Gateway.....	447
• Configuring an FA-PWWN for an HBA connected to an edge switch.....	447
• Supported switches and configurations for FA-PWWN.....	448
• Configuration upload and download considerations for FA-PWWN.....	449
• Security considerations for FA-PWWN.....	449
• Restrictions of FA-PWWN.....	449
• Access Gateway N_Port failover with FA-PWWN.....	450

## Fabric-Assigned PWWN overview

Fabric-Assigned PWWN simplifies server deployment in a Fibre Channel SAN (FC SAN) environment by using a virtual port World Wide Name (PWWN) instead of a physical PWWN to configure zoning and LUN mapping and masking.

Server deployment typically requires that multiple administrative teams (for example, server and storage teams) coordinate with each other to perform configuration tasks such as zone creation in the fabric and LUN mapping and masking on the storage device. These tasks must be completed before the server is deployed. Before you can configure WWN zones and LUN masks, you must find out the physical PWWN of the server. This means that administrative teams cannot start their configuration tasks until the physical server arrives (and its physical PWWN is known). Because the configuration tasks are sequential and interdependent across various administrative teams, it may take several days before the server gets deployed in an FC SAN.

You can use a fabric-assigned PWWN (FA-PWWN) to configure services such as zoning and LUN masking before you have a physical server. An FA-PWWN is a "virtual" port WWN that can be used instead of the physical PWWN. When the server is later attached to the SAN, the FA-PWWN is assigned to the server.

For example, you can use the FA-PWWN feature to perform the following tasks:

- Replace one server with another server, or replace failed HBAs or adapters within a server, without having to change any zoning or LUN mapping and masking configurations.
- Easily move servers across ports or Access Gateways by way of reassigning the FA-PWWN to another port.
- Use the FA-PWWN to represent a server in boot LUN zone configurations so that any physical server that is mapped to this FA-PWWN can boot from that LUN, thus simplifying boot over SAN configuration.

### NOTE

The server must use a supported HBA or adapter and must be enabled to use the FA-PWWN feature. Refer to the release notes for the HBA or adapter versions that support this feature.

You can configure an FA-PWWN for the following topologies:

- An FA-PWWN for an HBA device that is connected to an Access Gateway switch
- An FA-PWWN for an HBA device that is connected directly to an edge switch

FIGURE 65 Fabric-assigned port World Wide Name provisioning scenarios

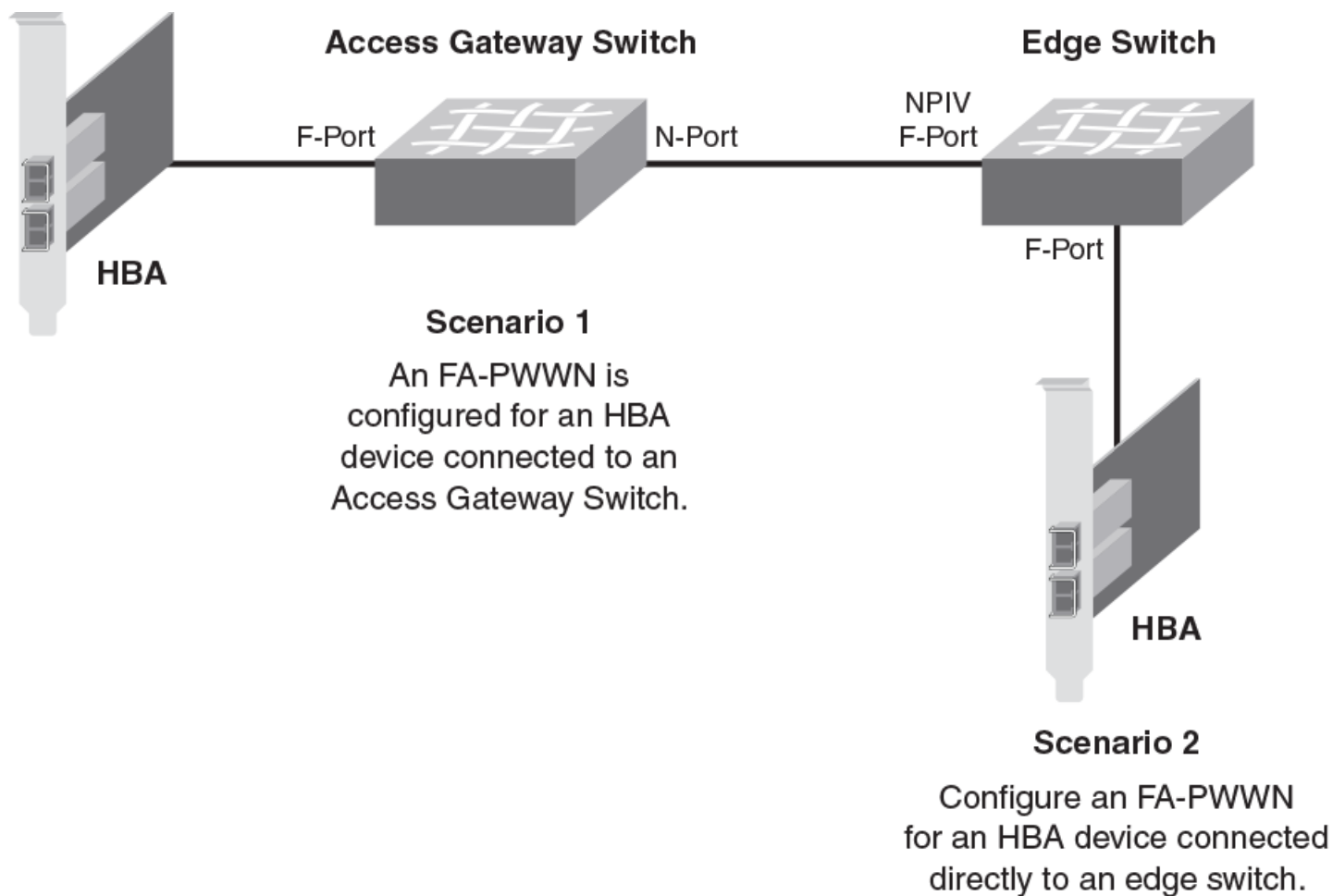

## User- and auto-assigned FA-PWWN behavior

Each switch port and Access Gateway port can have up to two FA-PWWNs, one assigned automatically and one assigned by the user. FA-PWWNs must be unique, and only one FA-PWWN can be active at any given time.

The automatically assigned FA-PWWN is created by default if you enable the feature without explicitly providing a virtual PWWN.

The user-assigned FA-PWWN takes precedence over the automatically assigned FA-PWWN. This means the switch will bind the user-assigned FA-PWWN to the port if both a user-assigned and an automatically assigned FA-PWWN are available. If you want to select the automatically assigned FA-PWWN over the user-assigned FA-PWWN, you must delete the user-assigned FA-PWWN from the port to which it has been assigned.

The switch ensures that automatically assigned FA-PWWNs are unique in a fabric. However, it is your responsibility to ensure that user-assigned FA-PWWNs are also unique throughout the fabric.

### ATTENTION

You must ensure that the same user-assigned FA-PWWN is not used in multiple chassis. There is no fabric-wide database, so adding the same FA-PWWNs in multiple chassis causes duplicate PWWNs.

## Configuring an FA-PWWN for an HBA connected to an Access Gateway

To configure an FA-PWWN, assign the FA-PWWN on the Access Gateway switch. The FA-PWWN feature is enabled by default on the HBA. Refer to the *Brocade Adapters Administrator's Guide* for a list of supported HBAs.

1. Log in to the edge switch to which the Access Gateway is directly connected.
2. Assign the FA-PWWN.

- If you are manually assigning a WWN, enter the following command:

```
fapwwn --assign -ag AG_WWN -port AG_port -v Virtual_PWWN
```

- If you want the WWN to be automatically assigned, enter the following command:

```
fapwwn --assign -ag AG_WWN -port AG_port
```

3. Display the FA-PWWN.

```
fapwwn --show -ag all
```

You should see output similar to the following sample. The FA-PWWNs are in the **Virtual Port WWN** column. (In this example, long lines of output are shown split across two lines, for better readability.)

```
-----
      AG Port                Port      Device Port WWN      \
-----
10:00:00:05:1e:65:8a:d5/16  --      --:--:--:--:--:--:-- \
10:00:00:05:1e:d7:3d:dc/8   20      20:08:00:05:1e:d7:2b:74 \
10:00:00:05:1e:d7:3d:dc/9   20      20:09:00:05:1e:d7:2b:73 \
10:00:00:05:1e:d7:3d:dc/16  --      --:--:--:--:--:--:-- \
-----
      Virtual Port WWN      PID      Enable MapType
-----
52:00:10:00:00:0f:50:30    --      Yes   AG/Auto
11:22:33:44:55:66:77:88    11403   Yes   AG/User
52:00:10:00:00:0f:50:33    11404   Yes   AG/Auto
52:00:10:00:00:0f:50:38    --      Yes   AG/Auto
-----
```

4. Display the FA-PWWN on the HBA.

The following steps are to be executed on the server and not the switch.

- a) Log in to the server as root.
- b) Enter the following command to display the FA-PWWN.

```
# bcu port --faa_query port_id

FAA state: Enabled
PWWN: 11:22:33:44:55:66:77:88
PWWN source: Fabric
```

The HBA retains the FA-PWWN until rebooted. This means you cannot unplug and plug the cable into a different port on the Access Gateway. You must reboot the HBA before moving the HBA to a different port.

If you move an HBA to a different port on a switch running Fabric OS v7.0.0 or later, the HBA will disable its port. The port remains disabled even if you then move the HBA to a port on a switch running a version of Fabric OS earlier than 7.0.0.

## Configuring an FA-PWWN for an HBA connected to an edge switch

To configure an FA-PWWN, assign the FA-PWWN on the edge switch. The FA-PWWN feature is enabled by default on the HBA. Refer to the *Brocade Adapters Administrator's Guide* for a list of supported HBAs.

1. Log in to the edge switch to which the device is connected.
2. Assign the FA-PWWN.
  - If you are manually assigning a WWN, enter the following command:

```
fapwwn --assign -port [slot/]port -v Virtual_PWWN
```

- If you want the WWN to be automatically assigned, enter the following command:

```
fapwwn --assign -port [slot/]port
```

3. Display the FA-PWWN.

```
fapwwn --show -port all
```

You should see output similar to the following sample. The FA-PWWNs are in the **VPWWN** column.

```
-----
Port      PPWWN                                VPWWN                                PID Enable MapType
-----
0  ---:---:---:---:---:---:---:---:  52:00:10:00:00:0f:50:30  10101 Yes  Port/Auto
1  ---:---:---:---:---:---:---:---:  11:22:33:44:33:22:11:22  --   Yes  Port/User
                                     52:00:10:00:00:0f:50:44
10 ---:---:---:---:---:---:---:---:  52:00:10:00:00:0f:50:45  --   Yes  Port/Auto
-----
```

4. Display the FA-PWWN on the HBA.

The following steps are to be executed on the server and not the switch.

- a) Log in to the server as root.
- b) Enter the following command to display the FA-PWWN.

```
# bcu port --faa_query port_id

FAA state: Enabled
PWWN: 11:22:33:44:33:22:11:22
PWWN source: Fabric
```

The HBA retains the FA-PWWN until it is rebooted. This means you cannot unplug and plug the cable into a different port on the switch. You must reboot the HBA before moving the HBA to a different port.

If you move an HBA to a different port on a switch running Fabric OS v7.0.0 or later, the HBA will disable its port. The port remains disabled even if you then move the HBA to a port on a switch running a version of Fabric OS earlier than 7.0.0.

## Supported switches and configurations for FA-PWWN

The FA-PWWN feature is supported only on switches running Fabric OS 7.0.0 or later and only on Brocade HBAs and adapters. The HBA can be connected to an edge switch or to an Access Gateway switch.

The FA-PWWN feature is supported on the following platforms:

- Gen 6 (32-Gbps) platforms running Fabric OS 8.0.x
  - Brocade G620
  - Brocade X6 Directors
- Switch platforms running Fabric OS v7.0.0 or later:
  - Brocade DCX 8510 Backbones
  - Brocade 6505
  - Brocade 6510

- Brocade 6520
- Access Gateway platforms running Fabric OS v7.0.0 or later:
  - Brocade 6505
  - Brocade 6510

Refer to the release notes for the supported Brocade HBA or adapter versions.

## Configuration upload and download considerations for FA-PWWN

The configuration upload and download utilities can be used to import and export the FA-PWWN configuration.

### ATTENTION

Brocade recommends you delete all FA-PWWNs from the switch with the configuration being replaced before you upload or download a modified configuration. This is to ensure no duplicate FA-PWWNs in the fabric.

## Security considerations for FA-PWWN

If security is a concern, ensure that only authorized users can configure FA-PWWNs. Device authentication and DCC policies provide additional security between the switch and the server.

The FA-PWWN feature can be enabled only by authorized administrators. Thus, existing user-level authentication and authorization mechanisms should be used to ensure only authorized users can configure this feature.

If you are concerned about security for FA-PWWNs, you should configure device authentication. You can use authentication at the device level to ensure security between the switch and the server. Refer to [Device authentication policy](#) on page 230 for information about configuring device authentication.

You can also use the Device Connection Control (DCC) policy to ensure that only an authorized physical server can connect to a specific switch port.

### NOTE

When creating the DCC policy, use the physical device WWN and not the FA-PWWN.

If you use DCC, a policy check is done on the physical PWWN on the servers. In the case of an HBA, the FA-PWWN is assigned to the HBA only after the DCC check is successful. Refer to [DCC policy behavior with Fabric-Assigned PWWNs](#) on page 224 for additional information.

## Restrictions of FA-PWWN

The FA-PWWN feature is not supported with some Fibre Channel fabric features.

FA-PWWN is not supported for the following:

- FCoE devices
- FL\_Ports
- Swapped ports (using the *portswap* command)
- Cascaded Access Gateway topologies
- FICON/FMS mode
- With F\_Port trunking on directly attached Brocade HBAs or adapters

**NOTE**

FA-PWWN is supported with F\_Port trunking on the supported Access Gateway platforms.

## Access Gateway N\_Port failover with FA-PWWN

If an Access Gateway is connected to multiple switches, you should configure the same FA-PWWNs on both switches to avoid having to reboot the host in case of failover.

If the same FA-PWWNs are not configured on the switches, and if an FA-PWWN F\_Port on an Access Gateway fails over to an N\_Port that is connected to a different switch, the FA-PWWN assigned to the Access Gateway F\_Port following the failover will be different than it was before the failover occurred. This situation may require the host to reboot to bring it back online. Even after the reboot, the host may potentially go into a different zone because the FA-PWWN is different.

# Inter-chassis Links

---

• Inter-chassis links .....	451
• ICLs between DCX 8510 Backbones.....	452
• ICLs between X6 Directors.....	455
• ICLs between DCX 8510 Backbones and X6 Directors.....	459
• Virtual Fabrics considerations for ICLs.....	462
• Supported topologies for ICL connections.....	463

## Inter-chassis links

An inter-chassis link (ICL) is a licensed feature used to interconnect the following chassis platforms. ICL ports in the core blades are used to interconnect the chassis platforms, potentially increasing the number of usable ports in the chassis platforms.

- Two Brocade DCX 8510 Backbones
- Two Brocade X6 Directors
- A Brocade DCX 8510 Backbone with a Brocade X6 Director

### NOTE

To connect a DCX 8510 Backbone to an X6 Director, you must fix the port speed on the X6 Director to 16 Gbps and use a 16 Gbps QSFP.

When two chassis platforms are interconnected by ICLs, each chassis requires a unique domain and is managed as a separate switch.

The ICL ports appear as regular ports, with some restrictions. All port parameters associated with ICL ports are static, and all **portCfg** commands are blocked from changing any of the ICL port parameters, except for EX\_Port and FEC port parameters. The only management associated with ICL ports and cables is monitoring the status of the LEDs on the ICL ports and any maintenance if the Attention LED is blinking yellow.

The ICL ports are managed as E\_Ports. You can also configure EX\_Ports on the ICLs. Refer to [Using FC-FC Routing to Connect Fabrics](#) on page 489 for instructions.

When you connect two chassis platforms, the following features are supported:

- Trunking
- Buffer-to-buffer credit sharing
- QoS

### NOTE

A Brocade trunking license is not required for trunking on ICL connections.

Refer to the specific hardware reference manuals for additional information about LED status meanings and ICL connections, including instructions on how to cable ICLs.

## License requirements for ICLs

ICL ports can be used only with an ICL license. An ICL license must be installed on both platforms forming the ICL connection.

All ICL ports must be disabled and then re-enabled for the license to take effect. After the addition or removal of an ICL license, the license enforcement is performed on the ICL ports only when you issue the **portDisable** and **portEnable** commands on the switch for the ports or the **bladeDisable** and **bladeEnable** commands for the core blade.

Enterprise ICL (EICL) license enforcement is applicable for Inter Fabric Links (IFL) via ICL links on Gen-5 platforms and is not applicable for Gen-6 platforms. In a mixed Gen-5 and Gen-6 environment, the edge fabric will additionally count the ICL IFL links for its license enforcement. When a Gen-5 chassis is connected to a Gen-6 chassis, the Gen-5 takes precedence and imposes the EICL license limit on the links. Prior to 8.0.1 release, only ICL ISLs were counted for license enforcement. In case of only Gen-6 platforms, there is no restriction on the number of switches that can be connected via ICL. In case of only Gen-5 platforms, if no EICL license is present, only 3 other direct chassis are allowed to connect (total 4).

In the case of 16-Gbps Gen 5 platforms, if EICL license is present, maximum of 9 chassis are allowed to connect (total of 10). The limit on the number of chassis depends only on the physical chassis and not on the logical switches.

For more information on how license enforcement occurs, refer to the *Fabric OS Software Licensing Guide*.

## Using the QSFPs that support 2 km on ICL ports

Prior to Fabric OS 7.3.0, all the FE ports and ICL ports used the same buffer credit model. In Fabric OS 7.3.0 and later, ICL ports support a 2 km distance. To support this distance, you must use specific QSFPs and allocate a greater number of buffer credits per port.

The following points should be considered if you are attempting to support 2 km links on ICL ports:

- Only the QSFPs that have the version number "57-1000310-01" and the serial number "HME114323P00044" support 2 km on ICLs. The second character ('M') in this serial number indicates that the QSFP supports 2 km distance. You can also use the **sfpShow** command to identify the QSFPs that support 2 km on ICL ports.
- The new credit model does not affect the HA configuration.
- You cannot downgrade from Fabric OS 7.3.0 to any earlier version if either of the following conditions is true:
  - When you have plugged in the QSFPs that support 2 km on one or more ICL ports.
  - When you have configured buffer credits using the **EportCredit** command on one or more ICL ports.
- The **portCfgEportCredits** configuration cannot have less than 5 buffer credits or more than 16 buffer credits per VC. If there are insufficient buffer credits available, the default configuration is retained and the message *Failed: already exceeds Buffer credits allowed* is displayed.
- Only a maximum of 10 ICL ports can be configured with 2 km QSFPs with 16 buffer credits per VC.
- Only a maximum of 14 ICL ports can be configured with 2 km QSFPs with 13 buffer credits per VC.

When you configure the 15<sup>th</sup> port using **portCfgEportCredit**, the message *Failed: already exceeds Buffer credits allowed* is displayed. The remaining two ports can have only 34 buffer credits. To remedy this, disable some ports and configure the remaining ports using 13 buffer credits per VC.

- If you are using the **portCfgEportCredit** command, a maximum of 16 buffer credits can be configured on all the ICL ports when all the 16 ICL ports are in the disabled state. After enabling all the ports, until the buffer credits are available, the ports will come up with the configured buffer credits. The remaining ports will come up in degraded mode. In case of remaining QoS-enabled ports, the ports will come up without QoS enabled. If all the ICL ports are QoS enabled, there will only be 448 buffer credits available for 2 km distance support.
- Due to the 2 km QSFP module limitation, the link failure counter is not reliable during module or cable removal or insertion.

## ICLs between DCX 8510 Backbones

Each ICL connects the core blades of two Brocade DCX 8510 chassis and provides up to 64 Gbps of throughput within a single cable.

You can have up to 32 QSFP ports in a Brocade DCX 8510-8 chassis or 16 QSFP ports in a Brocade DCX 8510-4 chassis, with up to 2 Tbps ICL bandwidth and support for up to 100 meters on universal optical cables.

The 100-meter ICL is supported beginning in Fabric OS 7.1.0, when using 100-meter-capable QSFPs over OM4 cable only.



The Brocade DCX 8510-8 has four port groups on the CR16-8 core blade. The Brocade DCX 8510-4 has two port groups on the CR16-4 core blade. Each port group has four QSFP connectors, and each QSFP connector maps to four user ports. Refer to the hardware reference manuals for details about the port groups.

The following table shows the mappings from the numbered QSFP ports on the face of the core blade to the individual FC port numbers as shown by the slotShow command.

**TABLE 87** External port to slotShow port mapping for core blades

External port number	slotShow FC port numbers	External port number	slotShow FC port numbers
0	0-3	8	32-35
1	4-7	9	36-39
2	8-11	10	40-43
3	12-15	11	44-47
4	16-19	12	48-51
5	20-23	13	52-55
6	24-27	14	56-59
7	28-31	15	60-63

Following are ICL configuration guidelines for trunking bandwidth and High Availability:

- ICLs must be installed in groups of two. Each pair of ICLs must be in the same port group.
- The recommended minimum number of ICLs between two Brocade DCX 8510 chassis is four. Additional ICLs should be added in increments of two, one on each core blade.
- For High Availability, you should have at least two ICLs from each core blade. [Figure 66](#) shows two Brocade DCX 8510-8 chassis connected with full redundancy using four ICL connections.

**FIGURE 66** Minimum configuration for 64 Gbps ICLs

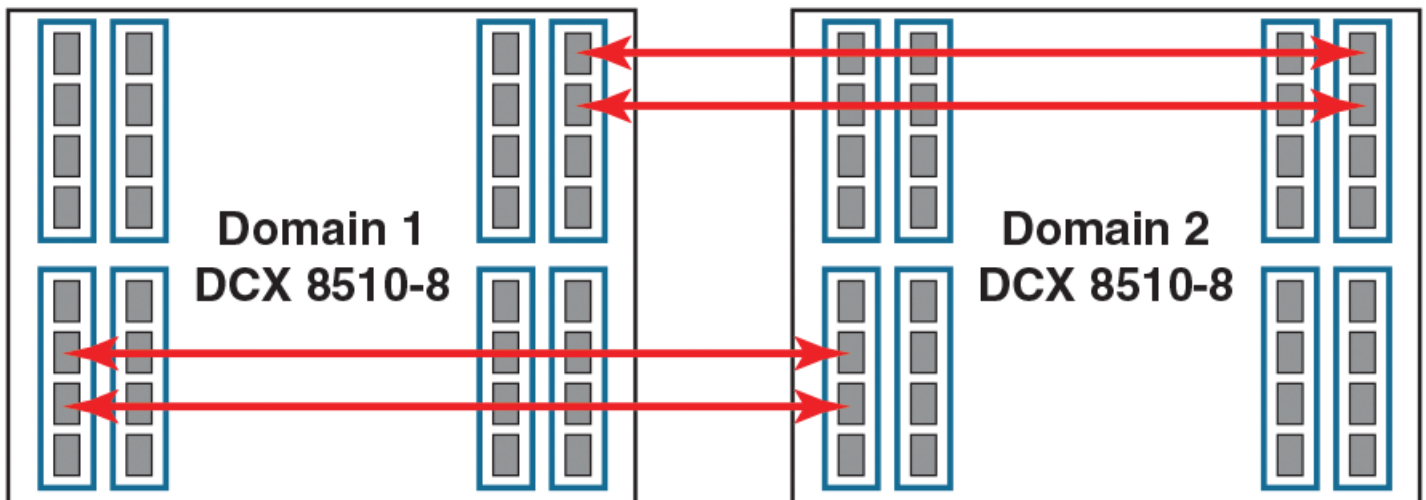

- The maximum number of ICLs between two Brocade DCX 8510-4 chassis or between a Brocade DCX 8510-8 and a Brocade DCX 8510-4 is 16.

The maximum number of ICLs between two Brocade DCX 8510-8 chassis is 32.

Because the FSPF routing logic uses only the first 16 paths to come online, only 16 ICLs are utilized. With Virtual Fabrics, however, you can define two logical switches on the chassis and have 16 ICLs in each.

#### NOTE

Brocade recommends that you have a maximum of eight ICLs connected to the same neighboring domain, with a maximum of four ICLs from each core blade.

- The ICLs can connect to either core blade in the neighboring chassis. Unlike the copper ICLs, the QSFP ICLs do not need to be cross-connected.

#### NOTE

QSFP ICLs and ISLs in the same logical switch and connected to the same neighboring switch are not supported. This is a topology restriction with 16 Gbps ICLs and any ISLs that are E\_Ports or VE\_Ports. If Virtual Fabrics is enabled, you can have ICLs and ISLs between a pair of Brocade DCX 8510 chassis if the ICLs are in a different logical switch than the ISLs.

## ICL trunking between Brocade DCX 8510 Backbones

ICL trunks form automatically but additional licenses may be required for enabling all ICL ports or for larger ICL configurations. For more information about ICL licensing options, refer to the *Fabric OS Software Licensing Guide*.

#### NOTE

Each QSFP cable has four ports, each terminating on a different ASIC. These ports cannot form a trunk with each other, but can form trunks only with corresponding ports on another QSFP.

Each core blade in the Brocade DCX 8510-8 contains 16 ICL trunk groups. Each core blade in the Brocade DCX 8510-4 contains 8 ICL trunk groups. Each ICL trunk group contains 4 user ports, one from each QSFP.

To establish ICL trunking between platforms in the Brocade DCX 8510 Backbone family, the QSFP cables must be in the same trunk group.

The following illustration marks the 4-port ICL trunking boundaries or port groups for DCX 8510 core routing blades (CR16-8 and CR16-4 blades):

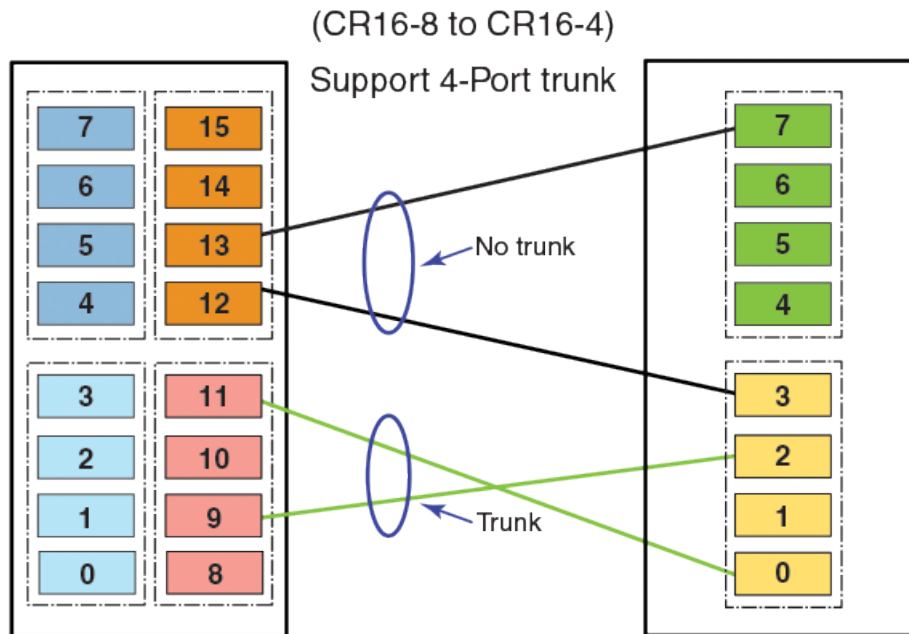

The following tables summarize the possible trunking connections between DCX 8510 Backbones:

Connecting blades	2 to 4-port ICL trunks
CR16-8 and CR16-8	Supported with QSFPs located within the same trunk group on each blade
CR16-8 and CR16-4	Supported with QSFPs located within the same trunk group on each blade
CR16-4 and CR16-4	Supported with QSFPs located within the same trunk group on each blade

Refer to the specific hardware reference manuals for information about port numbering, port trunk groups, and connecting the ICL cables.

## ICLs between X6 Directors

Up to eight directors can be connected through inter-chassis links (ICLs) between 4x32-Gbps QSFPs on core routing blades installed in X6 Directors

Each ICL connects the core blades of two Brocade X6 Director chassis and provides up to 128 Gbps of throughput within a single cable.

You can have up to 32 QSFP ports in a X6-8 chassis or 16 QSFP ports in a X6-4 chassis, with up to 4 Tbps ICL bandwidth and support for up to 100 meters on universal optical cables.

The 100-meter ICL is supported beginning in Fabric OS 8.0.1, when using 100-meter-capable QSFPs over OM4 cable only.

The Brocade X6-8 has four port groups on the CR32-8 core blade. The Brocade X6-4 has two port groups on the CR32-4 core blade. Each port group has four QSFP connectors, and each QSFP connector maps to four user ports.

The following table shows the mappings from the numbered QSFP ports on the face of the core blade to the individual FC port numbers as shown by the **slotShow** command.

**TABLE 88** External port to slotShow port mapping for core blades

External port number	slotShow FC port numbers	External port number	slotShow FC port numbers
0	0-3	8	32-35
1	4-7	9	36-39
2	8-11	10	40-43
3	12-15	11	44-47
4	16-19	12	48-51
5	20-23	13	52-55
6	24-27	14	56-59
7	28-31	15	60-63

Following are ICL configuration guidelines for trunking bandwidth and High Availability:

- A minimum of four ICL ports (two on each core blade) must be connected between each chassis pair.
- The dual connections on each core blade must reside within the same ICL trunk boundary on the core blades.
- If more than four ICL connections are required between a pair of X6 chassis, additional ICL connections should be added in pairs, one on each core blade with each additional pair residing within the same trunk boundary
- For High Availability, you should have at least two ICLs from each core blade. The following illustration shows two X6-8 chassis connected with full redundancy using four ICL connections.

FIGURE 67 Minimum configuration for 128 Gbps ICLs

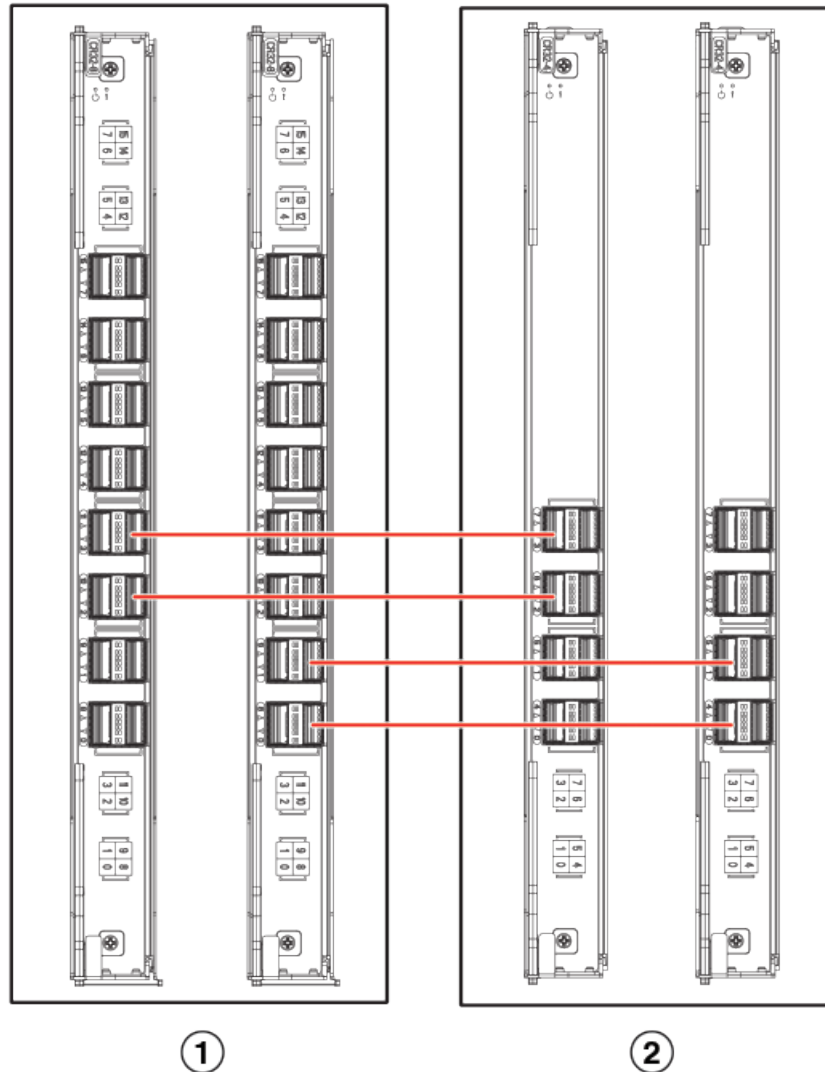

1. X6-8 Chassis with two CR32-8 blades

2. X6-4 Chassis with two CR32-4 blades

- The maximum number of ICLs between two X6-4 chassis or between a X6-8 and a X6-4 is 16.

The maximum number of ICLs between two X6-8 chassis is 32.

Because the FSPF routing logic uses only the first 16 paths to come online, only 16 ICLs are utilized. With Virtual Fabrics, however, you can define two logical switches on the chassis and have 16 ICLs in each.

#### NOTE

Brocade recommends that you have a maximum of eight ICLs connected to the same neighboring domain, with a maximum of four ICLs from each core blade.

- The ICLs can connect to either core blade in the neighboring chassis. The QSFP ICLs do not need to be cross-connected.

**NOTE**

QSFP ICLs and ISLs in the same logical switch and connected to the same neighboring switch are not supported. This is a topology restriction with 16 Gbps ICLs and any ISLs that are E\_Ports or VE\_Ports. If Virtual Fabrics is enabled, you can have ICLs and ISLs between a pair of X6 chassis if the ICLs are in a different logical switch than the ISLs.

## ICL trunking between Brocade X6 Directors

Trunking optimizes the use of ICL bandwidth by allowing a group of links to merge into a single logical link, called a trunk. Traffic is distributed dynamically and in order over this trunk, achieving greater performance with fewer links. Within the trunk, multiple physical ports appear as a single port, thus simplifying management. Trunking also improves system reliability by maintaining in-order delivery of data and avoiding I/O retries if one link within the trunk fails.

Each QSFP provides four 32 Gbps FC ports. Since each port within a QSFP terminates on a different ASIC within each core blade, an ICL trunk cannot be formed using the individual FC ports within the same QSFP. A trunk has to be formed from individual FC ports in different QSFP ports. These QSFP ports must reside in the same trunk group. To form an ICL trunk between two devices, a minimum of two QSFPs within a port trunk group on a core blade installed in one device must be connected to a pair of QSFPs within a trunk group on a core blade in another device using ICLs.

ICL trunks form automatically but additional licenses may be required for enabling all ICL ports or for larger ICL configurations. For more information about ICL licensing options, refer to the *Fabric OS Software Licensing Guide*.

**NOTE**

Each QSFP cable has four ports, each terminating on a different ASIC. These ports cannot form a trunk with each other, but can form trunks only with corresponding ports on another QSFP.

Each core blade in the Brocade X6-8 contains 16 ICL trunk groups. Each core blade in the Brocade X6-4 contains 8 ICL trunk groups. Each ICL trunk group contains 4 user ports, one from each QSFP. To establish ICL trunking between platforms in the Brocade X6 Director family, the QSFP cables must be in the same trunk group. Up to four 4x32 Gbps QSFP ports in a trunk group can form a 512 Gbps trunk between two CR32-4 or CR32-8 blades.

The following illustration marks the 4-port ICL trunking boundaries or port groups for X6 core routing blades (CR32-8 and CR32-4 blades):

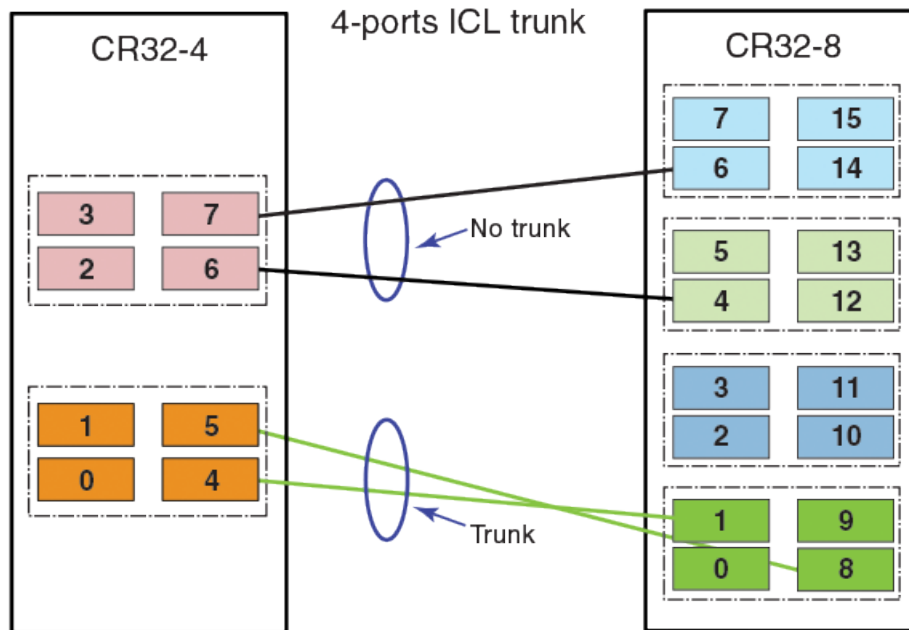

Ports belonging to the same trunking groups are indicated with the same color border under the ports on the blade faceplate. These colors are also applied to the port map labels on each blade faceplate to indicate ports belonging to the same trunking groups. Although a connection between two QSFPs on one core routing blade and two QSFPs on another blade in a different device are required to form ICL trunk, you can create trunks consisting of two to four QSFP connections between these blades.

#### NOTE

You cannot configure ISLs using ports on port blades and QSFP-based ICLs using ports on core routing blades concurrently on the same chassis.

The following tables summarize the possible trunking connections between X6 Directors:

Connecting blades	2 to 4-port ICL trunks
CR32-8 and CR32-8	Supported with QSFPs located within the same trunk group on each blade
CR32-8 and CR32-4	Supported with QSFPs located within the same trunk group on each blade
CR32-4 and CR32-4	Supported with QSFPs located within the same trunk group on each blade

Refer to the specific hardware reference manuals for information about port numbering, port trunk groups, and connecting the ICL cables.

## ICLs between DCX 8510 Backbones and X6 Directors

Each ICL connects the core blade of a Brocade DCX 8510 chassis with an X6 Director chassis and provides up to 64 Gbps of throughput within a single cable. You must set the port speed to 16 Gbps and use the 16 Gbps QSFP to interconnect on the X6 Director.

You can have up to 32 QSFP ports in a Brocade DCX 8510-8/X6-8 chassis, and 16 QSFP ports in a Brocade DCX 8510-4/X6-4 chassis, with up to 2 Tbps ICL bandwidth and support for up to 100 meters on universal optical cables.

The 100-meter ICL is supported beginning in Fabric OS 8.0.1, when using 100-meter-capable QSFPs over OM4 cable only.

The Brocade DCX 8510-8/X6-8 has four port groups on the CR16-8/CR32-8 core blade. The Brocade DCX 8510-4/X6-4 has two port groups on the CR16-4/CR32-4 core blade. Each port group has four QSFP connectors, and each QSFP connector maps to four user ports. Refer to the hardware reference manuals for details about the port groups. Note the port numbers that form a port group in Gen 5 vs Gen 6 CR blades represented in the following illustration. Each four ports that have the same color representation form a port group.

**FIGURE 68** Port groups in Gen 5 CR blades vs Gen 6 CR blades

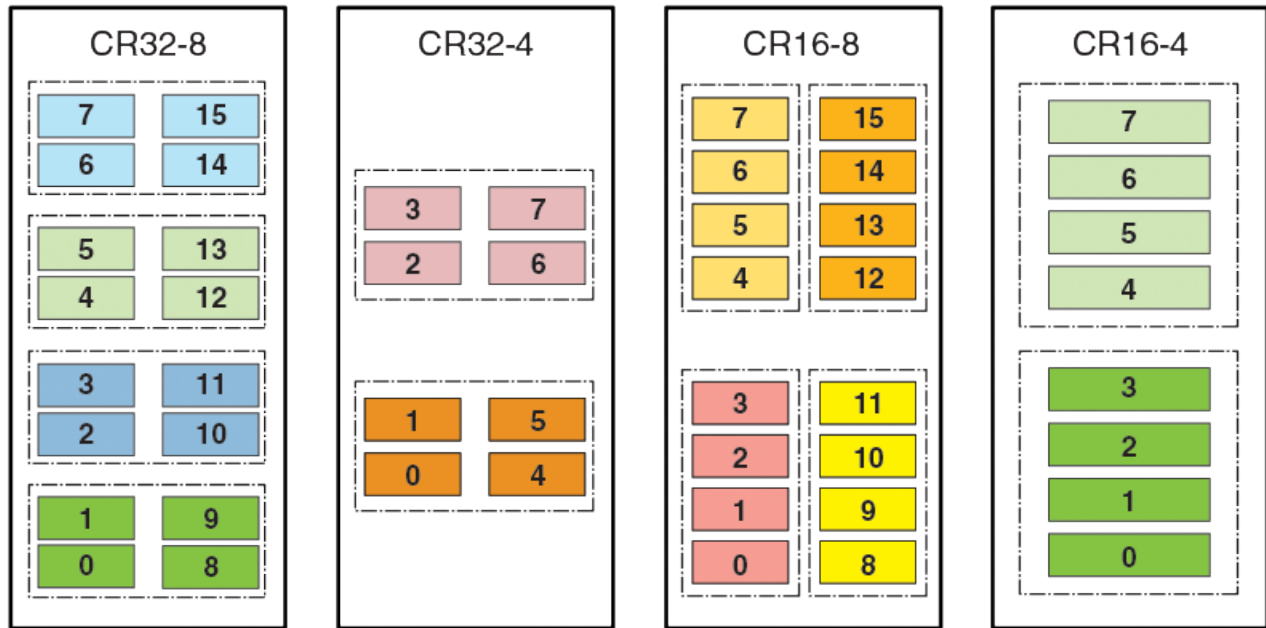

Following are ICL configuration guidelines for trunking bandwidth and High Availability:

- ICLs must be installed in groups of two. Each pair of ICLs must be in the same port group.
- The recommended minimum number of ICLs between a DCX 8510 chassis and an X6 Director chassis is four. Additional ICLs should be added in increments of two, one on each core blade.
- For High Availability, you should have at least two ICLs from each core blade.
- The maximum number of ICLs between two DCX 8510-4/X6-4 chassis or between a Brocade DCX 8510-8/X6-8 chassis and a Brocade DCX 8510-4/X6-4 chassis is 16.

The maximum number of ICLs between two DCX 8510-8/X6-8 chassis is 32.

Because the FSPF routing logic uses only the first 16 paths to come online, only 16 ICLs are utilized. With Virtual Fabrics, however, you can define two logical switches on the chassis and have 16 ICLs in each.

#### NOTE

Brocade recommends that you have a maximum of eight ICLs connected to the same neighboring domain, with a maximum of four ICLs from each core blade.

- The ICLs can connect to either core blade in the neighboring chassis. Unlike the copper ICLs, the QSFP ICLs do not need to be cross-connected.



**NOTE**

QSFP ICLs and ISLs in the same logical switch and connected to the same neighboring switch are not supported. This is a topology restriction with 16 Gbps ICLs and any ISLs that are E\_Ports or VE\_Ports. If Virtual Fabrics is enabled, you can have ICLs and ISLs between a pair of DCX 8510 Backbone/X6 Director chassis if the ICLs are in a different logical switch than the ISLs.

## ICL trunking between DCX 8510 Backbones and X6 Directors

ICL trunks form automatically but additional licenses may be required for enabling all ICL ports or for larger ICL configurations. For more information about ICL licensing options, refer to the *Fabric OS Software Licensing Guide*.

**NOTE**

Each QSFP cable has four ports, each terminating on a different ASIC. These ports cannot form a trunk with each other, but can form trunks only with corresponding ports on another QSFP.

Each core blade in the Brocade DCX 8510-8 and X6-8 contains 16 ICL trunk groups. Each core blade in the Brocade DCX 8510-4 and X6-4 contains 8 ICL trunk groups. Each ICL trunk group contains 4 user ports, one from each QSFP.

To establish ICL trunking between platforms in the Brocade DCX 8510 Backbone family and X6 Director family, the QSFP cables must be in the same trunk group. Each ICL that connects the core blades between the Gen 5 and Gen 6 platforms provides up to 64 Gbps of throughput within a single cable.

**NOTE**

When you connect DCX 8510 Backbone ICL ports with X6 Director ICL ports, you must use the Gen 5 4x16 Gbps QSFPs on the Gen 6 (X6 Director) ICL ports and set the port speed to 16 Gbps on the X6 Directors.

The following tables summarize the possible trunking connections between a DCX 8510 Backbone and an X6 Director:

Connecting blades	2 to 4-port ICL trunks
CR32-8 and CR16-8	Supported with QSFPs located within the same trunk group on each blade
CR32-8 and CR16-4	Supported with QSFPs located within the same trunk group on each blade
CR32-4 and CR16-8	Supported with QSFPs located within the same trunk group on each blade
CR32-4 and CR16-4	Supported with QSFPs located within the same trunk group on each blade

The following illustrations provides a sample of ICL trunks between DCX 8510 Backbones and X6 Directors.



Refer to the specific hardware reference manuals for information about port numbering, port trunk groups, and connecting the ICL cables.

## Virtual Fabrics considerations for ICLs

In Virtual Fabrics, the ICL ports can be split across the logical switch, base switch, and default switch. The triangular topology requirement must be met for each fabric individually.

The following restrictions apply:

- ICL ports cannot be in a logical switch that is using XISLs. The "Allow XISL Use" attribute for the switch must be off.

## Supported topologies for ICL connections

You can connect the Brocade Backbones and/or Directors in a mesh topology and a core-edge topology. A brief description of each follows. (You can also connect two DCX 8510 chassis or X Directors point-to-point.)

The illustrations in this section show sample topologies. Refer to the *Brocade SAN Scalability Guidelines* for details about maximum topology configurations.

### Mesh topology

You can connect the Brocade Backbones or Directors in a mesh topology, in which every chassis is connected to every other chassis.

#### NOTE

A maximum of 9 chassis can be connected to form a mesh topology.

A simple form of the mesh topology is the triangular topology (shown in the following illustration). The triangular topology is supported by three Brocade Backbone or Director chassis. The chassis for each topology must all be from the same family:

- Brocade X6 Director family (X6-8 or X6-4)
- Brocade DCX 8510 Backbone family (DCX 8510-8 or DCX 8510-4)

FIGURE 69 Three Brocade X6-8 chassis in full mesh triangular ICL topology

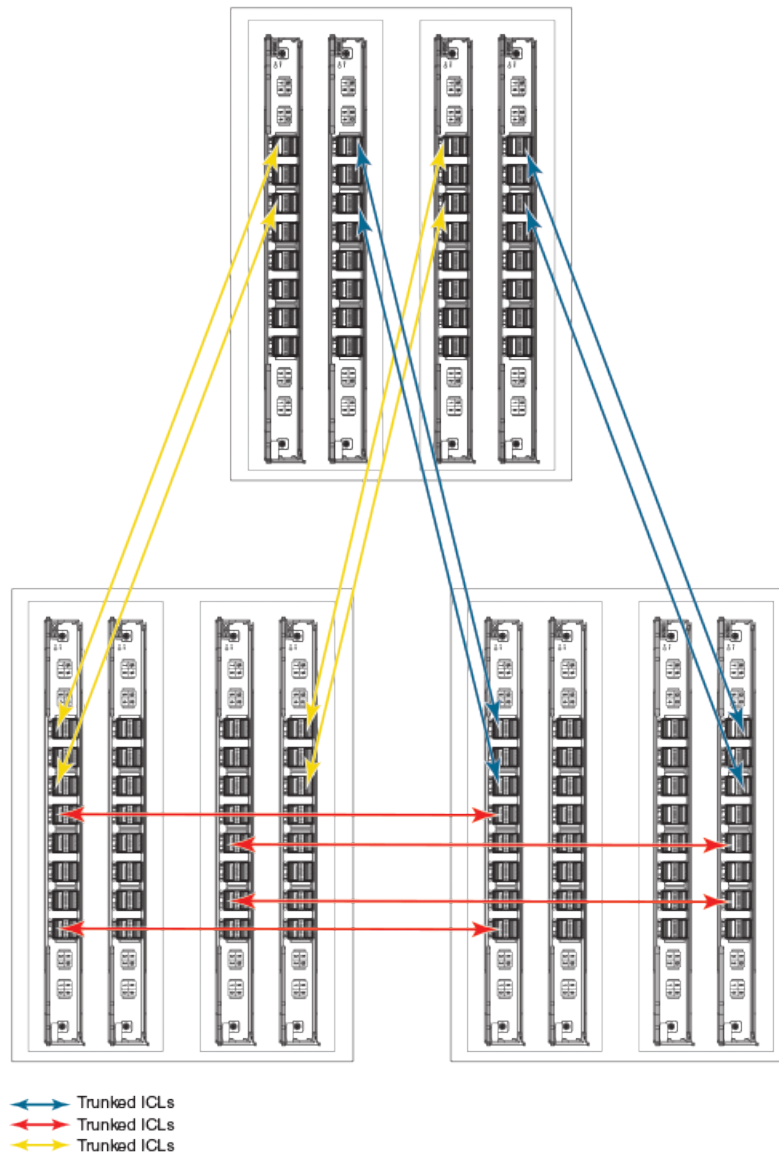

During an ICL break in the triangular topology, the chassis that has the connections of the other two is the main chassis. Any error messages relating to a break in the topology appear in the RASlog of the main chassis.

*For the Brocade DCX Backbone family only:* If one ICL is broken but there is a regular ISL, the triangular topology holds given that the ISL cost is lower than the total cost through the ICL linear topology. If a direct ICL link between two chassis is broken, the triangular topology is considered broken when the ISL path between the two switches is a multiple hop. In this case, the triangular topology broken message is posted independently of the cost of the ISL path being lesser or greater than the ICL path between the two switches.

Another form is the full nine-mesh topology shown in [Figure 70](#). This topology is supported by DCX 8510-8 Backbones only. (You can use DCX 8510-4 Backbones for a five-mesh topology.)

FIGURE 70 Full nine-mesh topology

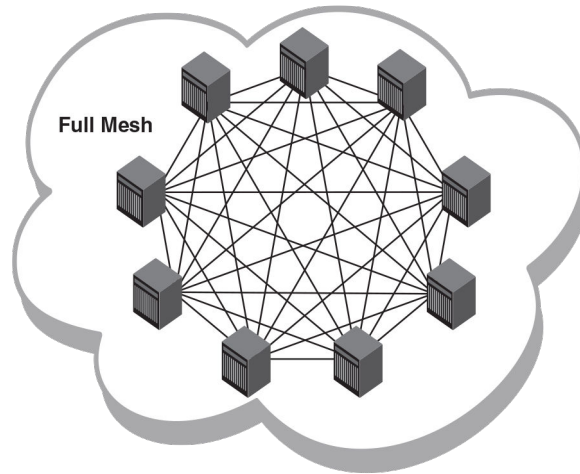

## Core-edge topology

### NOTE

A maximum of 12 chassis can be interconnected to form a core-edge topology using ICL links.

You can also connect the Brocade DCX 8510 Backbones in a core-edge topology. For example, [Figure 71](#) shows six chassis connected in a core-edge topology (four edges and two cores). Although [Figure 71](#) shows only the Brocade DCX 8510-8, each chassis can be either a Brocade DCX 8510-4 or a DCX 8510-8. You can have up to eight edges with DCX 8510-8 cores or up to four edges with DCX 8510-4 cores.

Similarly, you can also connect the Brocade X6 Directors in a core-edge topology. For example, [Figure 71](#) shows six chassis connected in a core-edge topology (four edges and two cores). Although [Figure 71](#) shows only the Brocade X6-8, each chassis can be either a Brocade X6-4 or a X6-8. You can have up to eight edges with X6-8 cores or up to four edges with X6-4 cores.

Each line in [Figure 71](#) represents four QSFP cables. The cabling scheme should follow the parallel example shown in [Figure 66](#) on page 453.

FIGURE 71 Gen 5 DCX 8510 64 Gbps ICL core-edge topology

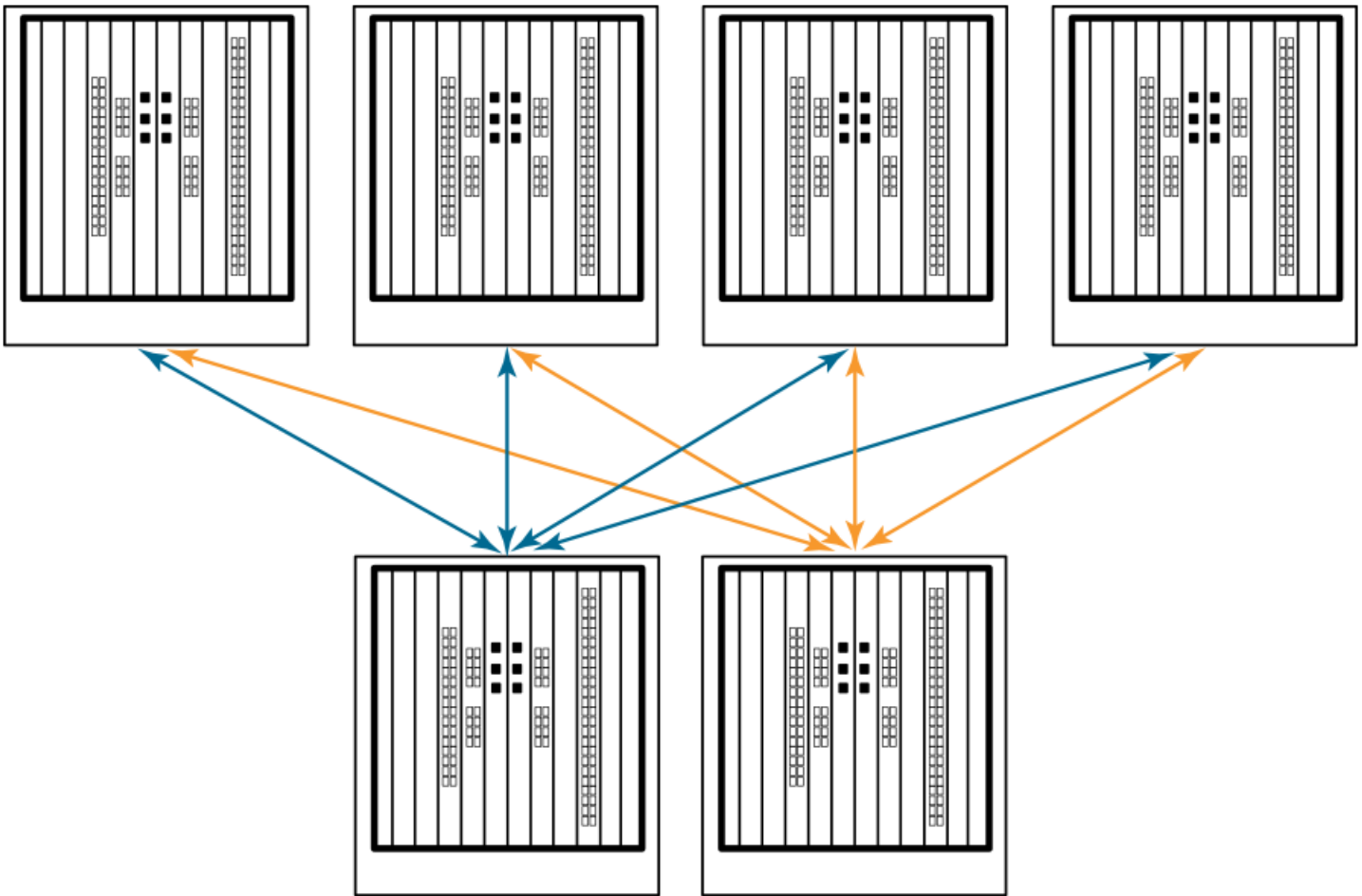

# Managing Trunking Connections

---

• Trunking overview.....	467
• Supported platforms for trunking.....	469
• Supported configurations for trunking.....	469
• Requirements for trunk groups.....	469
• Recommendations for trunk groups.....	470
• Configuring trunk groups.....	471
• Enabling trunking.....	471
• Disabling trunking.....	471
• Displaying trunking information.....	472
• ISL trunking over long-distance fabrics.....	473
• EX_Port trunking.....	474
• F_Port trunking.....	475
• Displaying F_Port trunking information.....	481
• Disabling F_Port trunking.....	481
• Enabling the DCC policy on a trunk area.....	482

## Trunking overview

Trunking optimizes the use of bandwidth by allowing a group of links to merge into a single logical link, called a *trunk group*. Traffic is distributed dynamically and in order over this trunk group, achieving greater performance with fewer links. Within the trunk group, multiple physical ports appear as a single port, thus simplifying management. Trunking also improves system reliability by maintaining in-order delivery of data and avoiding I/O retries if one link within the trunk group fails.

Trunking is frame-based instead of exchange-based. Because a frame is much smaller than an exchange, this means that frame-based trunks are more granular and better balanced than exchange-based trunks and provide maximum utilization of links.

The Trunking license is required for any type of trunking, and must be installed on each switch that participates in trunking. For details on obtaining and installing licensed features, refer to the *Fabric OS Software Licensing Guide*.

## Types of trunking

Trunking can be between two switches, between a switch and an Access Gateway module, or between a switch and a Brocade adapter. The types of trunking are as follows:

- ISL trunking, or E\_Port trunking, is configured on an inter-switch link (ISL) between two Fabric OS switches and is applicable only to E\_Ports.
- ICL trunking is configured on an inter-chassis link (ICL) between two Brocade DCX 8510 Backbones and/or X6 Directors and is applicable only to ports on the core blades.

Refer to [Inter-chassis Links](#) on page 451 for detailed information about ICL trunking.

- EX\_Port trunking is configured on an inter-fabric link (IFL) between an FC router (EX\_Port) and an edge fabric (E\_Port). The trunk ports are EX\_Ports connected to E\_Ports.

Refer to [EX\\_Port trunking](#) on page 474 for additional information about EX\_Port trunking.

- F\_Port trunking is configured on a link between a switch and either an Access Gateway module or a Brocade adapter. The trunk ports are F\_Ports (on the switch) connected to N\_Ports (on the Access Gateway or adapter).

- N\_Port trunking is configured on a link between a switch and either an Access Gateway module or a Brocade adapter. It is similar to F\_Port trunking. The trunk ports are N\_Ports (on the Access Gateway or adapter) connected to F\_Ports (on the switch).

For more information, refer to [Configuring F\\_Port trunking for a Brocade adapter](#) on page 478, the *Access Gateway Administrator's Guide*, and the *Brocade Adapters Administrators Guide*.

#### NOTE

This chapter uses the term *F\_Port trunking* to refer to a trunk between the F\_Ports on a switch and the N\_Ports on either an Access Gateway module or a Brocade adapter. This type of trunk might be referred to as N\_Port trunking in the *Access Gateway Administrator's Guide* or *Brocade Adapters Administrator's Guide*.

## Masterless trunking

Masterless trunking means that if the master port goes offline, one of the slave ports automatically becomes the new master port, thus avoiding traffic disruption. The new master port uses the old master port area and the old master port is assigned a new, unused area. In this way, the port identifier (PID) of the trunk does not change if the master port goes offline.

If trunking is not masterless, and if the master port goes offline, traffic disruption can occur because the slave ports in the trunk group go offline to select the new master port and then come back online.

Masterless trunking is supported for most platforms and trunking types:

- All F\_Port trunking is masterless.
- ISL and ICL trunking are masterless.
- EX\_Port trunking is masterless, except on Brocade DCX 8510 Backbones and X6 Directors with Virtual Fabrics disabled.

## License requirements for trunking

Trunking of non-ICL ports (E\_Ports, EX\_Ports, and F\_Ports) requires the Trunking license. This license must be installed on each switch that participates in trunking.

Trunking of ICL ports (E\_Ports and EX\_Ports) does not require a Trunking license.

#### ATTENTION

After you add the Trunking license, to enable trunking functionality, you must disable and then re-enable each port to be used in trunking, or disable and re-enable the switch.

Refer to the *Fabric OS Software Licensing Guide* for information about activating licenses.

## Port groups for trunking

For trunk groups to form, several conditions must be met. One of the conditions is that all of the ports in a trunk group must belong to the same port group. A *port group* is a group of eight ports, based on the user port number, such as 0-7, 8-15, 16-23, and up to the number of ports on the switch. The maximum number of port groups is platform-specific.

Ports in a port group are usually contiguous, but they may not be. Refer to the hardware reference manual for your switch for information about which ports can be used in the same port group for trunking.



FIGURE 72 Port group configuration for the Brocade G620

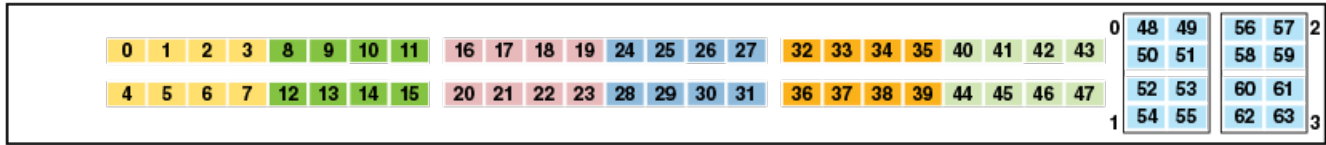

## Supported platforms for trunking

Trunking is supported on the FC ports of all Brocade platforms and blades supported in Fabric OS v7.0.0 and later.

EX\_Port trunking is supported only on those platforms that support EX\_Ports. Refer to [Supported platforms for FC-FC routing](#) on page 490 for more information.

## Supported configurations for trunking

- Links within a trunk can be 4 Gbps, 8 Gbps, 10 Gbps, 16 Gbps, or 32 Gbps depending on the Brocade platform.

### NOTE

32 Gbps QSFP ports can be used to create trunks between a pair of Brocade G620 for ISL, and between a pair of Brocade X6 Directors for ICL. Refer to [ICL trunking between Brocade X6 Directors](#) on page 458 for ICL trunking detail.

- The maximum number of ports per trunk is generally eight, but the number of trunks per switch depends on the Brocade platform.
- You can have up to eight ports in one trunk group to create high-performance ISL trunks between switches, providing up to 128 Gbps (based on a 16-Gbps port speed).
- An E\_Port or EX\_Port trunk can be up to eight ports wide. All the ports must be adjacent to each other, in the clearly marked groups on the front of the switch.

Trunks operate best when the cable length of each trunked link is roughly equal to the length of the others in the trunk. For optimal performance, no more than 30 meters difference is recommended. Trunks are compatible with both short-wavelength (SWL) and long-wavelength (LWL) fiber-optic cables and transceivers.

Trunking is performed according to the Quality of Service (QoS) configuration on the master and the slave ports. That is, in a given trunk group, if there are some ports with QoS enabled and some with QoS disabled, they form two different trunks, one with QoS enabled and the other with QoS disabled.

## High Availability support for trunking

Trunking is a High Availability (HA) supported feature. The HA protocol for trunking is as follows:

- If trunking is disabled prior to the HA failover, it remains disabled after the HA failover.
- If trunking is enabled prior to the HA failover, it remains enabled after the HA failover.

## Requirements for trunk groups

The following requirements apply to all types of trunking:

- All of the ports in a trunk group must belong to the same port group.
- All of the ports in a trunk group must meet the following conditions:
  - They must be running at the same speed.
  - They must be configured for the same distance.
  - They must have the same QoS and FEC state.
  - They must have the same encryption and compression state.
- Trunk groups must be between Brocade switches (or Brocade adapters in the case of F\_Port trunking).
- There must be a direct connection between participating switches.
- Trunking cannot be done if ports are in ISL R\_RDY mode. (You can disable this mode by using the **portCfgIslMode** command.)
- Trunking is supported only on FC ports. Virtual FC ports (VE\_Ports or VEX\_Ports) do not support trunking.

## Recommendations for trunk groups

To identify the most useful trunk groups, consider the following recommendations along with the standard guidelines for SAN design:

- Evaluate the traffic patterns within the fabric.
- Place trunking-capable switches adjacent to each other.

This maximizes the number of trunk groups that can form. If you are using a core and edge topology, place trunking-capable switches at the core of the fabric and any switches that are not trunking-capable at the edge of the fabric.

- When connecting two switches with two or more ISLs, ensure that all trunking requirements are met to allow a trunk group to form.
- Determine the optimal number of trunk groups between each set of linked switches, depending on traffic patterns and port availability.

The goal is to avoid traffic congestion without unnecessarily using ports that could be used to attach other switches or devices.

- Each physical ISL uses two ports that could otherwise be used to attach node devices or other switches.
- Trunk groups can be used to resolve ISL oversubscription if the total capability of the trunk group is not exceeded.
- Consider how the addition of a new path will affect existing traffic patterns:
  - A trunk group has the same link cost as the master ISL of the group, regardless of the number of ISLs in the group. This allows slave ISLs to be added or removed without causing data to be rerouted, because the link cost remains constant.
  - The addition of a path that is shorter than existing paths causes traffic to be rerouted through that path.
  - The addition of a path that is longer than existing paths may not be useful, because the traffic will choose the shorter paths first.
- Plan for future bandwidth addition to accommodate increased traffic.

For trunk groups over which traffic is likely to increase as business requirements grow, consider leaving one or two ports in the group available for the future nondisruptive addition of bandwidth.

- Consider creating redundant trunk groups where additional ports are available or paths are particularly critical.

This helps to protect against oversubscription of trunk groups, multiple ISL failures in the same group, and the rare occurrence of an ASIC failure.

- To provide the highest level of reliability, deploy trunk groups in redundant fabrics to help ensure that ISL failures do not disrupt business operations.

## Configuring trunk groups

After you install the Trunking license, you must re-initialize the ports that are to be used in trunk groups so that they recognize that trunking is enabled. This procedure needs to be performed only once, and is required for all types of trunking.

To re-initialize the ports, you can either disable and then re-enable the switch, or disable and then re-enable the affected ports.

1. Connect to the switch and log in using an account assigned to the admin role.
2. Enter the **islShow** command to determine which ports are used for ISLs.

```
switch:admin> islshow
1: 0-> 0 10:00:00:05:1e:a2:f9:b1 3 SW_43 sp: 4.000G bw: 4.000G TRUNK
QOS
2: 10-> 1 10:00:00:05:33:88:a1:d0 1 bodc_switch_sw_66_rename_limit sp: 16.000G bw: 16.000G TRUNK
QOS CR_RECOV FEC
3: 12-> 2 10:00:00:05:33:88:a1:d0 1 bodc_switch_sw_66_rename_limit sp: 8.000G bw: 8.000G TRUNK
QOS CR_RECOV
4: 16-> 0 10:00:00:05:1e:a1:99:09 5 bodc_switch_20_chars sp: 8.000G bw: 8.000G QOS
```

3. Enter the **portDisable** command for each port to be used in a trunk group.  
Alternatively, you can enter the **switchDisable** command to disable all ports on the switch.
4. Enter the **portEnable** command for each port that you disabled in step 3, or enter the **switchEnable** command to enable all of the ports on the switch.

### NOTE

F\_Port trunking requires additional steps to configure the Trunk Area (TA). Refer to [Configuring F\\_Port trunking for an Access Gateway](#) on page 477 or [Configuring F\\_Port trunking for a Brocade adapter](#) on page 478 for information.

## Enabling trunking

You can enable trunking for a single port or for an entire switch. Because trunking is automatically enabled when you install the Trunking license, you need to use this procedure only if trunking has been subsequently disabled on a port or switch. Enabling trunking disables and re-enables the affected ports. As a result, traffic through these ports may be temporarily disrupted.

1. Connect to the switch and log in using an account assigned to the admin role.
2. Enter the **portCfgTrunkPort** command to enable trunking on a port. Enter the **switchCfgTrunk** command to enable trunking on all ports on the switch.

```
portcfgtrunkport[slot/]port mode
switchcfgtrunk mode
```

Mode 1 enables trunking.

In the following example, trunking is being enabled on slot 1, port 3.

```
switch:admin> portcfgtrunkport 1/3 1
```

## Disabling trunking

You can disable trunking for a single port or for an entire switch. Disabling trunking disables and re-enables the affected ports. As a result, traffic through these ports may be temporarily disrupted.

Trunking on ICLs is always enabled and cannot be disabled.

Disabling trunking fails if a Trunk Area (TA) is enabled on the port. Use the **portTrunkArea** command to remove the TA before disabling trunking.

1. Connect to the switch and log in using an account assigned to the admin role.
2. Enter the **portCfgTrunkPort** command to disable trunking on a port. Enter the **switchCfgTrunk** command to disable trunking on all ports on the switch.

```
portcfgtrunkport[slot/]port mode
switchcfgtrunk mode
```

Mode 0 disables trunking.

```
switch:admin> switchcfgtrunk 0
```

## Displaying trunking information

You can use the **trunkShow** command to view the following information:

- All the trunks and members of a trunk.
- Whether the trunking port connection is the master port connection for the trunk group.
- Whether trunks are formed correctly.
- Trunking information for a switch that is part of an FC router backbone fabric interlinking several edge fabrics.
- Trunking information, including bandwidth and throughput for all the trunk groups in a switch.

Use the **portPerfShow** command to monitor problem areas where there are congested paths or dropped links to determine whether you need to adjust the fabric design by adding, removing, or reconfiguring ISLs and trunking groups. For additional information on traffic monitoring, refer to *Flow Vision Administrator's Guide*.

To view detailed information about F\_Port trunking, refer to [Displaying F\\_Port trunking information](#) on page 481.

Use the following procedure to view trunking information:

1. Connect to the switch and log in using an account assigned to the admin role.
2. Enter the **trunkShow** command.

The following example shows trunking groups 1, 2, and 3; ports 4, 13, and 14 are masters.

```
switch:admin> trunkshow
1: 6-> 4 10:00:00:60:69:51:43:04 99 deskew 15 MASTER
2: 15-> 13 10:00:00:60:69:51:43:04 99 deskew 16 MASTER
      12-> 12 10:00:00:60:69:51:43:04 99 deskew 15
      14-> 14 10:00:00:60:69:51:43:04 99 deskew 17
      13-> 15 10:00:00:60:69:51:43:04 99 deskew 16
3: 24-> 14 10:00:00:60:69:51:42:dd 2 deskew 15 MASTER
```

The following example shows trunking information along with the bandwidth and throughput for all the trunk groups in a switch.

```
switch:admin> trunkshow -perf

1: 2-> 2 10:00:00:05:1e:81:56:8b 1 deskew 15 MASTER
   3-> 3 10:00:00:05:1e:81:56:8b 1 deskew 17
   Tx: Bandwidth 4.00Gbps, Throughput 1.66Gbps (48.45%)
   Rx: Bandwidth 4.00Gbps, Throughput 1.66Gbps (48.44%)
   Tx+Rx: Bandwidth 8.00Gbps, Throughput 3.33Gbps (48.44%)
2: 5->113 10:00:00:05:1e:46:42:01 3 deskew 15 MASTER
   4->112 10:00:00:05:1e:46:42:01 3 deskew 15
   Tx: Bandwidth 16.00Gbps, Throughput 1.67Gbps (12.12%)
   Rx: Bandwidth 16.00Gbps, Throughput 1.67Gbps (12.12%)
   Tx+Rx: Bandwidth 32.00Gbps, Throughput 3.33Gbps (12.12%)
3: 10-> 10 10:00:00:05:1e:81:56:8b 1 deskew 15 MASTER
   11-> 11 10:00:00:05:1e:81:56:8b 1 deskew 15
   Tx: Bandwidth 4.00Gbps, Throughput 1.66Gbps (48.45%)
   Rx: Bandwidth 4.00Gbps, Throughput 1.67Gbps (48.48%)
   Tx+Rx: Bandwidth 8.00Gbps, Throughput 3.33Gbps (48.46%)
4: 12->892 10:00:00:05:1e:46:42:01 3 deskew 15 MASTER
   13->893 10:00:00:05:1e:46:42:01 3 deskew 15
   Tx: Bandwidth 16.00Gbps, Throughput 1.67Gbps (12.12%)
   Rx: Bandwidth 16.00Gbps, Throughput 1.66Gbps (12.11%)
   Tx+Rx: Bandwidth 32.00Gbps, Throughput 3.33Gbps (12.11%)
```

## ISL trunking over long-distance fabrics

In long-distance fabrics, if a port speed is set to autonegotiate, then the maximum speed is assumed for reserving buffers for the port. If the port is running at only 2 Gbps, this wastes buffers. For long-distance ports, you should specify the port speed instead of setting it to autonegotiate.

In addition to the criteria listed in [Supported configurations for trunking](#) on page 469, observe the following criteria for trunking over long-distance fabrics:

- Trunking over long-distance fabrics is supported only on switches running Fabric OS v6.1.0 and later.
- Extended Fabrics and Trunking licenses are required on all participating switches.
- When configuring long distance, you must configure the `portCfgLongDistance --vc_translation_link_init` parameter to be the same on all ports in a long-distance fabric.

For additional information on configuring long distance, refer to [Configuring an extended ISL](#) on page 484.

[Table 89](#) summarizes support for trunking over long distance for the Brocade DCX and DCX 8510 Backbones and supported blades.

**TABLE 89** Trunking over long distance for the Brocade Backbones and blades

Long-distance mode	Distance	Number of 2-Gbps ports	Number of 4-Gbps ports
LE	10 km	48 (six 8-port trunks)	48 (six 8-port trunks)
LO	Normal	See note below	48 (six 8-port trunks)
LD	200 km	4 (one 2-port trunk per switch)	0
LD	250 km	4 (one 2-port trunk per switch)	0
LD	500 km	0	0
LS	Static	See note below	

### NOTE

The LO mode supports up to 5 km at 2 Gbps, up to 2 km at 4 Gbps, and up to 1 km at 8/10 Gbps, 625 m at 16 Gbps and 150 m at 32 Gbps. The distance for the LS mode is static. You can specify any distance greater than 10 km.

The distance supported depends on the available buffers, the number of back-end ports, and the number of ports that are offline. For more information on setting port speeds, refer to [Performing Advanced Configuration Tasks](#) on page 69.

## EX\_Port trunking

You can configure EX\_Ports to use trunking just as you do regular E\_Ports. EX\_Port trunking support is designed to provide the best utilization and balance of frames transmitted on each link between the FC router and the edge fabric. You should trunk all ports connected to the same edge fabrics.

The FC router front domain has a higher node WWN, derived from the FC router, than that of the edge fabric. Therefore, the FC router front domain initiates the trunking protocol on the EX\_Port.

After initiation, the first port from the trunk group that comes online is designated as the master port. The other ports that come online on the trunk group are considered to be the slave ports. Adding or removing a slave port does not cause frame drop. However, removing a slave port causes the loss of frames in transit.

If router port cost is used with EX\_Port trunking, the master port and slave ports share the router port cost of the master port.

The restrictions for EX\_Port frame trunking are the same as for E\_Ports. All the ports must be adjacent to each other, in the clearly marked groups on the front of the switch.

### ATTENTION

EX\_Port trunking should be enabled only if the entire configuration is running Fabric OS v5.2.0 or later.

Refer to [Using FC-FC Routing to Connect Fabrics](#) on page 489 for more information about EX\_Ports and the FC router.

## Masterless EX\_Port trunking

EX\_Port trunking is masterless except for EX\_Ports on Brocade DCX and DCX 8510 Backbones.

For the Backbones, Virtual Fabrics must be enabled for masterless EX\_Port trunking to take effect. For the fixed-port switches, Virtual Fabrics can be enabled or disabled.

If masterless EX\_Port trunking is not in effect and the master port goes offline, the entire EX\_Port-based trunk re-forms and is taken offline for a short period of time. If there are no other links to the edge fabric from the Backbone, the master port going offline may cause a traffic disruption in the backbone fabric.

## Supported configurations and platforms for EX\_Port trunking

EX\_Port trunking is a Fiber Channel Routing (FCR) software feature and requires that you have a Trunking license installed on the FC router and on the edge fabric connected to the other side of the trunked EX\_Ports. The Trunking license is not required for EX\_Ports on an ICL.

EX\_Port trunking is supported only with Brocade edge fabrics.

You can use EX\_Port frame trunking in the following configurations and cases:

- For ports with speeds of 2 Gbps up to maximum speed and trunking over long distance.
- In the edge fabric, when the FC router is connected to a switch that supports eight ports from the trunkable group.
- When the FC router is connected to an edge fabric through a mix of trunked and nontrunked EX\_Ports; all will share the same front domain.
- In edge-to-edge, backbone-to-edge, and dual-backbone configurations.

Masterless EX\_Port trunking has additional configuration requirements. Refer to [Masterless EX\\_Port trunking](#) on page 474 for these additional requirements.

#### NOTE

QoS and EX\_Port trunking can coexist. However, if some ports in the trunk group have QoS enabled and some have QoS disabled, then two trunk groups will form: one with QoS enabled and one with QoS disabled.

## Backward compatibility support

For backward compatibility, an FC router that supports EX\_Port trunking can continue to interoperate with older FC routers and all previously supported Brocade switches in the backbone fabric or Brocade edge fabric.

## Configuring EX\_Port trunking

With EX\_Port trunking, you use the same CLI commands as you do for E\_Port trunking. Refer to [Configuring trunk groups](#) on page 471 for instructions.

## Displaying EX\_Port trunking information

1. Log in as an admin and connect to the switch.
2. Enter the **switchShow** command to display trunking information for the EX\_Ports.

The following is an example of a master EX\_Port and a slave EX\_Port displayed in **switchShow** output.

```
switch:admin> switchshow
Index Slot Port Address Media Speed State
=====
16 2 0 ee1000 id N4 No_Light
17 2 1 ee1100 id N4 Online EX_Port (Trunk port, master is Slot 2 Port 2 )
18 2 2 ee1200 id N4 Online EX_Port 10:00:00:05:1e:35:bb:32 "MtOlympus_82" (fabric id =
2 ) (Trunk master)
19 2 3 ee1300 id N4 No_Light
20 2 4 ee1400 id N4 Online EX_Port (Trunk port, master is Slot 2 Port 7 )
21 2 5 ee1500 id N4 Online EX_Port (Trunk port, master is Slot 2 Port 7 )
22 2 6 ee1600 id N4 Online EX_Port (Trunk port, master is Slot 2 Port 7 )
23 2 7 ee1700 id N4 Online EX_Port 10:00:00:60:69:80:1d:bc "MtOlympus_72" (fabric id =
2 ) (Trunk master)
```

## F\_Port trunking

You can configure F\_Port trunking in the following scenarios:

- Between F\_Ports on a Fabric OS switch and N\_Ports on an Access Gateway module
- Between F\_Ports on a Fabric OS switch and N\_Ports on adapters that are compatible with Brocade Trunking technology.

For F\_Port trunking, you must create a Trunk Area (TA) within the trunk group. When you assign an area within a trunk group, that group is enabled for F\_Port trunking. The TA that you assign must be within the 8-port trunk group beginning with port 0 (zero). After you assign a TA to a port, the port immediately acquires the TA as the area of its PID. Likewise, after you remove a TA from a port, the port immediately acquires the default area as its PID. F\_Port trunking prevents reassignments of the Port ID (also referred to as the Address Identifier) when F\_Ports go offline, and it increases F\_Port bandwidth.

#### NOTE

Ensure that the Trunking license is enabled on the connecting Access Gateway module before creating a TA on the edge Switch. Do not create a TA if the connecting Access Gateway Module has no trunking capability (that is, no Trunking license or the Trunking license is disabled). Doing so will cause the corresponding N\_ports on the Access Gateway module to be disabled.

Refer to the *Access Gateway Administrator's Guide* for information about configuring the corresponding N\_Port trunking on the Access Gateway.

## F\_Port trunking for Access Gateway

You can configure trunking between the F\_Ports on an edge switch and the N\_Ports on an Access Gateway module.

**NOTE**

You cannot configure F\_Port trunking on the F\_Ports of an Access Gateway module.

F\_Port trunking keeps F\_Ports from becoming disabled when they are mapped to an N\_Port on a switch in Access Gateway (AG) mode. With F\_Port trunking, any link within a trunk can go offline or become disabled, but the trunk remains fully functional and there are no reconfiguration requirements.

Figure 73 shows a switch in AG mode without F\_Port masterless trunking. Figure 74 shows a switch in AG mode with F\_Port masterless trunking.

FIGURE 73 Switch in Access Gateway mode without F\_Port masterless trunking

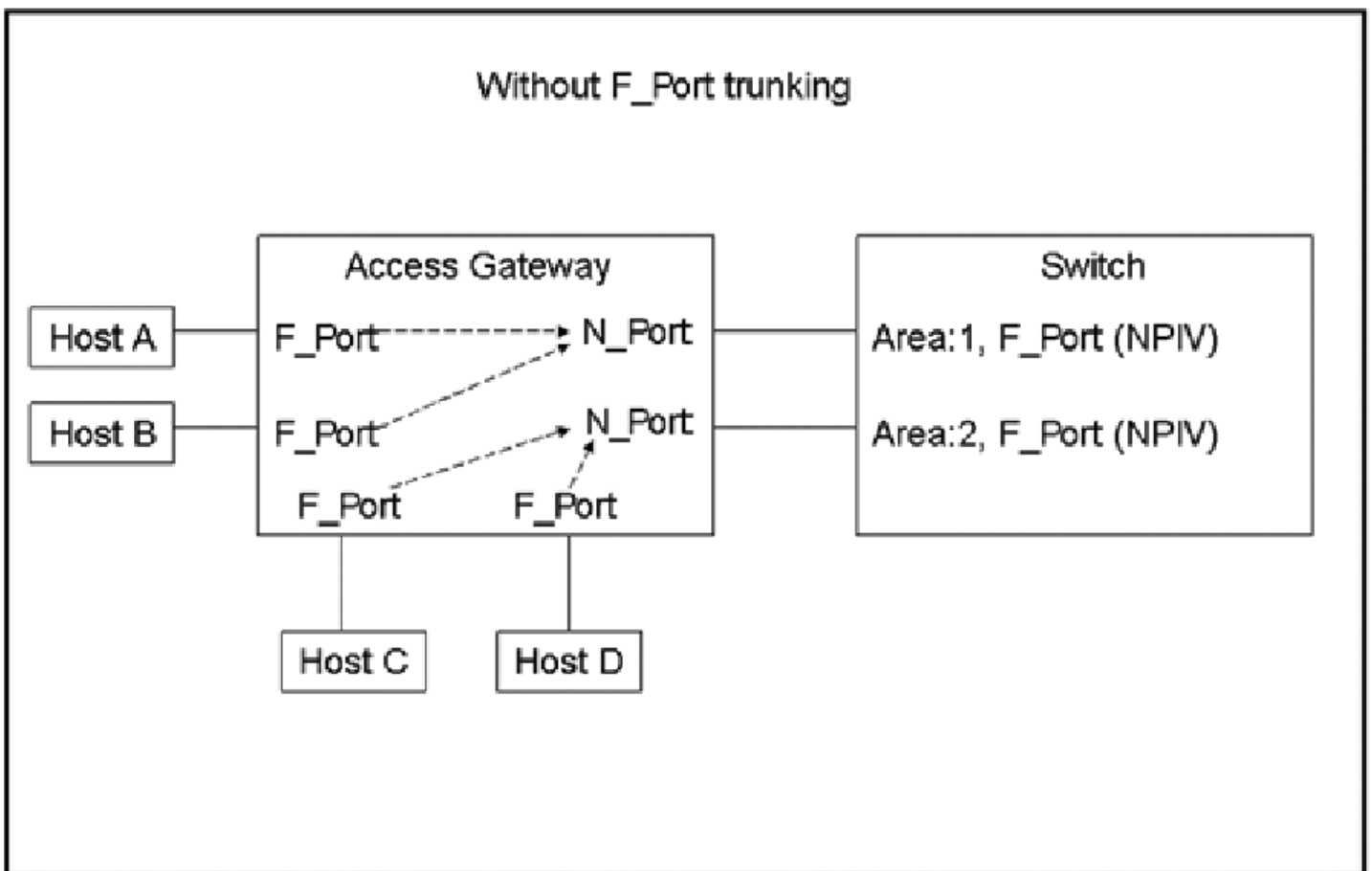
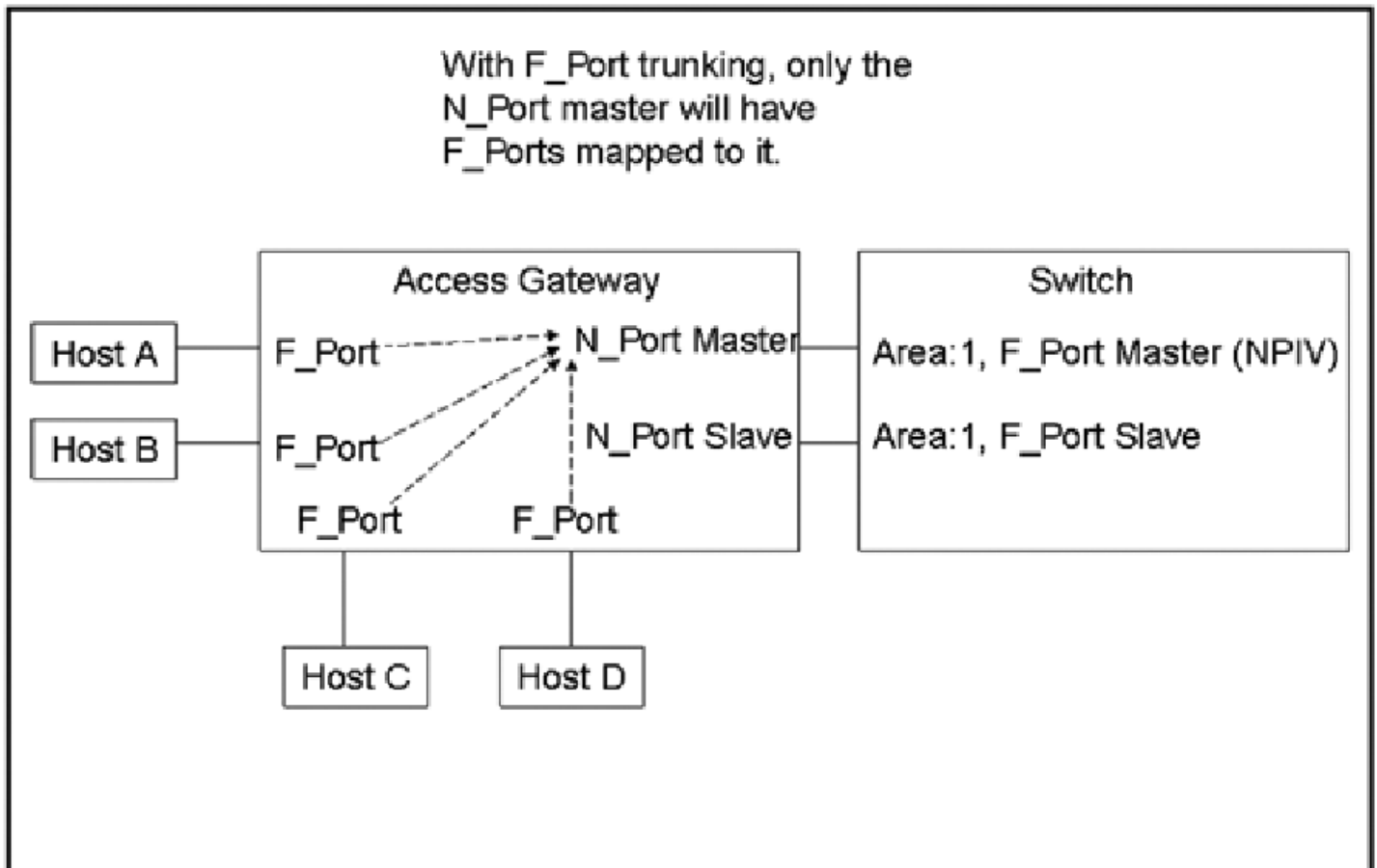



FIGURE 74 Switch in Access Gateway mode with F\_Port masterless trunking

**NOTE**

You do not need to map the host to the master port manually because the Access Gateway will perform a cold failover to the master port.

Refer to [Configuring F\\_Port trunking for an Access Gateway](#) on page 477 for instructions on configuring F\_Port trunking.

### Requirements for F\_Port trunking on an Access Gateway

In addition to the requirements listed in [Requirements for trunk groups](#) on page 469, refer to the *Access Gateway Administrator's Guide* for additional requirements that are specific to F\_Port trunking on an Access Gateway.

### Configuring F\_Port trunking for an Access Gateway

Access Gateway trunking configuration is mostly on the edge switch. On the Access Gateway module, you only need to ensure that the Trunking license is applied and enabled.

Use the following procedure on the edge switch connected to the Access Gateway module to configure F\_Port trunking.

1. Connect to the switch and log in using an account assigned to the admin role.

2. Enter the **portCfgShow** command to ensure that the ports have trunking enabled. If trunking is not enabled, enter the **portCfgTrunkPort** *port1* command.
3. Enter the **portDisable** command for each port to be included in the TA.
4. Enter the **portTrunkArea --enable** command to enable the trunk area.

For example, the following command creates a TA for ports 36-39 with index number 37.

```
switch:admin> porttrunkarea --enable 36-39 -index 37
Trunk index 37 enabled for ports 36, 37, 38 and 39.
```

When you assign a trunk area on a port, trunking is automatically enabled on the F\_Ports. The **portTrunkArea** command does not unassign a TA if its previously assigned Area\_ID is the same Address Identifier (Area\_ID) of the TA unless all the ports in the trunk group are specified to be unassigned.

5. Enter the **portEnable** command to re-enable the ports in the TA.

## F\_Port trunking for Brocade adapters

You can configure trunking between the F\_Ports on an edge switch and the Brocade adapters.

In addition to the requirements listed in [Requirements for trunk groups](#) on page 469, note the following requirements, which are specific to F\_Port trunking for Brocade adapters:

- The edge switch must be running in Native mode. You cannot configure trunking between the Brocade adapters and the F\_Ports of an Access Gateway module.
- You can configure only two F\_Ports in one trunk group.

Refer to the *Brocade Adapters Administrator's Guide* for information about configuring the corresponding N\_Port trunking on the Access Gateway and the Brocade adapter.

## Configuring F\_Port trunking for a Brocade adapter

F\_Port trunking for Brocade adapters requires configuration on the FC switch as well as on the Brocade HBAs. This section describes the configuration steps you perform on the switch. Refer to the *Brocade Adapters Administrator's Guide* for a detailed description and requirements of N\_Port trunking on the adapters.

1. On the switch side, perform the following steps:
  - a) Configure both ports for trunking by using the **portCfgTrunkPort** command.

```
switch:admin> portcfgtrunkport 3/40 1
switch:admin> portcfgtrunkport 3/41 1
```

- b) Disable the ports to be used for trunking by using the **portDisable** command.

```
switch:admin> portdisable 3/40
switch:admin> portdisable 3/41
```

- c) Enable the trunk on the ports by using the **portTrunkArea** command.

```
switch:admin> porttrunkarea --enable 3/40-41 -index 296
Trunk index 296 enabled for ports 3/40 and 3/41.
```

2. On the host side, enable trunking as described in the *Brocade Adapters Administrator's Guide*.
3. On the switch side, enable the ports by using the **portEnable** command.

```
switch:admin> portenable 3/40
switch:admin> portenable 3/41
```

## F\_Port trunking considerations

Table 90 describes the F\_Port masterless trunking considerations.

**TABLE 90** F\_Port masterless trunking considerations

Category	Description
Area assignment	<p>You statically assign the area within the trunk group on the edge switch. That group is the F_Port trunk.</p> <p>The static trunk area you assign must fall within the ASIC's trunk group of the switch or blade starting from port 0, and must be one of the port's default areas of the trunk group.</p> <p>10-bit addressing is the default mode for all dynamically created partitions in the Brocade DCX and DCX 8510-8 platforms.</p>
Authentication	<p>Authentication occurs only on the F_Port trunk master port and only once per the entire trunk. This behavior is the same as E_Port trunk master authentication. Because only one port in the trunk does FLOGI to the switch, and authentication follows FLOGI on that port, only that port displays the authentication details when you issue the <b>portShow</b> command.</p> <p><b>NOTE</b> Switches in Access Gateway (AG) mode do not perform authentication.</p>
configdownload	<p>If you issue the <b>configDownload</b> command for a port configuration that is not compatible with F_Port trunking, and the port is Trunk Area-enabled, then the port will be persistently disabled. F_Port trunks will never be restored through <b>configDownload</b>.</p> <p><b>NOTE</b> Long distance, port mirroring, non-CORE_PID, and FastWrite are not compatible with F_Port trunking.</p>
domain,index (D,I)	<p>Creating a Trunk Area may remove the Index (I) from the switch to be grouped to the Trunk Area. All ports in a Trunk Area share the same index. This means that a <i>domain,index</i> (D,I), which refers to an index that might have been removed, will no longer be part of the switch.</p> <p><b>NOTE</b> Be sure to include zoning and DCC when creating a Trunk Area.</p> <p>You can remove the port from the Trunk Area to place the index back in effect. D,I behaves as normal, but you may see the effects of grouping ports into a single index.</p> <p>Also, D,I continues to work for Trunk Area groups. The index can be used in D,I if it was the index for the Trunk Area group.</p>
DCC Policy	<p>DCC policy enforcement for the F_Port trunk is based on the Trunk Area; the FDISC requests to a trunk port are accepted only if the WWN of the attached device is part of the DCC policy against the Trunk Area. The PWWN of the FLOGI sent from the Access Gateway will be dynamic for the F_Port trunk master. Because you do not know ahead of time what PWWN the Access Gateway will use, the PWWN of the FLOGI will not go through DCC policy check on an F_Port trunk master. However, the PWWN of the FDISC will continue to go through DCC policy check.</p>
Default Area	<p>Port X is a port that has its Default Area the same as its Trunk Area. The only time you can remove port X from the trunk group is when the entire trunk group has the Trunk Area disabled.</p>
Downgrade	<p>You can have trunking on, but you must disable the trunk ports before performing a firmware downgrade.</p> <p><b>ATTENTION</b> Removing a Trunk Area on ports running traffic is disruptive because you must disable the port to disable the Trunk Area on the port. Use caution before assigning a Trunk Area if you need to downgrade to a firmware version earlier than Fabric OS 6.2.0.</p>
FastWrite	<p>When you assign a Trunk Area to a trunk group, the trunk group cannot have FastWrite enabled on those ports. If a port is FastWrite-enabled, the port cannot be assigned a Trunk Area.</p>
FICON	<p>FICON is not supported on F_Port trunk ports. However, FICON can still run on ports that are not F_Port trunked within the same switch.</p>
HA Sync	<p>If you plug in a standby CP with a firmware version earlier than Fabric OS 6.2.0 and a Trunk Area is present on the switch, the CP blades will become out of sync.</p>

**TABLE 90** F\_Port masterless trunking considerations (continued)

Category	Description
Long Distance	Long distance is not allowed on F_Port trunks, which means that a Trunk Area is not allowed on long-distance ports. You cannot enable long distance on ports that have a Trunk Area assigned to them.
Management Server	Registered Node ID (RNID), Link Incident Record Registration (LIRR), and Query Security Attribute (QSA) ELSs are not supported on F_Port trunks.
NPIV	N_Port ID virtualization (NPIV) is supported on the F_Port master trunk.
PID format	F_Port trunking is supported only in the CORE PID format.
Port mirroring	Port mirroring is not supported on Trunk Area ports or on the PID of an F_Port trunk port. Port mirroring is not supported on the Brocade Encryption Switch.
Port Swap	When you assign a Trunk Area to a trunk group, the Trunk Area cannot be port swapped. If a port is swapped, then you cannot assign a Trunk Area to that port.
Port Types	Only F_Port trunk ports are allowed on a Trunk Area port. All other port types are persistently disabled.
PWWN	The entire Trunk Area trunk group shares the same Port WWN within the trunk group. The PWWN is the same across the entire F_Port trunk that has either 0x2f or 0x25 as the first byte of the PWWN. The Trunk Area is part of the PWWN in the format listed in <a href="#">Table 91</a> .
QoS	QoS is supported.
Routing	Routing will route against the F_Port trunk master. Bandwidth information will be modified accordingly as the F_Port trunk forms.
Trunk Master	No more than one trunk master is allowed in a trunk group. The second trunk master will be persistently disabled with the reason "Area has been acquired".
Upgrade	There are no limitations on upgrading to Fabric OS 7.0.0 and later if the F_Port is present on the switch. Upgrading is not disruptive.

## PWWN formats for F\_Port trunk ports

The following table describes the PWWN formats for F\_Port trunk ports. The initial 5 is the default value for an F\_Port trunk port in a virtual fabric. The initial 2 is the default value for an F\_Port trunk port that is not in a virtual fabric.

Virtual fabric (NAA = 5)	5n:nn:nn:nn:nn:xx:xx	The valid range of x:xx is 0-4095.
Non-virtual fabric (NAA = 2)	25:xx:nn:nn:nn:nn:nn	The valid range of xx is 0-255.
	2F:xx:nn:nn:nn:nn:nn	The valid range of xx is 0-255.

Refer to [Logical ports](#) on page 278 for more information on PWWN construction.

## F\_Port trunking in Virtual Fabrics

F\_Port trunking functionality performs the same in Virtual Fabrics as it does in non-Virtual Fabrics platforms except for the Brocade DCX 8510-8. Fabric OS uses a 10-bit addressing model.

On the DCX 8510 platforms and X6 Directors, F\_Port trunk ports dynamically receive an 8-bit area address that remains persistent. After F\_Port trunking configurations are removed from a port in a logical switch, that port returns to the default 10-bit area addressing model, which supports up to 1024 F\_Ports in a logical switch.

### NOTE

DCX 8510-8 platforms have a maximum of 576 ports. Out of the 1024 10-bit address range, addresses 448-1023 are reserved for the 10-bit address space. Addresses 0-447 are reserved for assigning to NPIV/Loop ports to support 112 (448/4) NPIV/Loop ports in a logical switch with 256 devices each.

The following are the F\_Port trunking considerations for Virtual Fabrics:

- If a port is enabled for F\_Port trunking, you must disable the configuration before you can move a port from the logical switch.
- If the user-bound area for a port is configured by means of the **portAddress** command, the port cannot be configured as an F\_Port trunk port. You must explicitly remove the user-bound area before enabling F\_Port trunking.
- If you swap a port by using the **portSwap** command, you must undo the port swap before enabling F\_Port trunking.
- F\_Port trunks are not allowed on the base switch because you cannot have F\_Ports on the base switch.
- If F\_Port trunking is enabled on some ports in the default switch, and you disable Virtual Fabrics, all of the F\_Port trunking information is lost.
- All of the ports in an F\_Port trunk must belong to a single trunk group of ports on the platform and must also belong to the same logical switch.

Refer to [Managing Virtual Fabrics](#) on page 267 for detailed information about Virtual Fabrics.

## Displaying F\_Port trunking information

Use the following commands on the edge switch to verify the F\_Port trunking configuration.

- Enter **switchShow** to display the switch and port information.
- Enter **portTrunkArea --show enabled** to display the Trunk Area-enabled port configuration.

```
switch:admin> porttrunkarea --show enabled
Port  Type  State  Master  TI  DI
-----
36    F-port  Master 36      37  36
37    F-port  Slave  36      37  37
38    F-port  Slave  36      37  38
39    F-port  Slave  36      37  39
```

- Enter **portTrunkArea --show trunk** to display the trunking information.

```
switch:admin> porttrunkarea --show trunk
Trunk Index 37: 39->0 sp: 8.000G bw: 16.000G deskew 15 MASTER
Tx: Bandwidth 16.00Gbps, Throughput 1.63Gbps (11.84%)
Rx: Bandwidth 16.00Gbps, Throughput 1.62Gbps (11.76%)
Tx+Rx: Bandwidth 32.00Gbps, Throughput 3.24Gbps (11.80%)
38->1 sp: 8.000G bw: 8.000G deskew 15
Tx: Bandwidth 16.00Gbps, Throughput 1.63Gbps (11.84%)
Rx: Bandwidth 16.00Gbps, Throughput 1.62Gbps (11.76%)
Tx+Rx: Bandwidth 32.00Gbps, Throughput 3.24Gbps (11.80%)
37->1 sp: 8.000G bw: 8.000G deskew 15
Tx: Bandwidth 16.00Gbps, Throughput 1.63Gbps (11.84%)
Rx: Bandwidth 16.00Gbps, Throughput 1.62Gbps (11.76%)
Tx+Rx: Bandwidth 32.00Gbps, Throughput 3.24Gbps (11.80%)
36->1 sp: 8.000G bw: 8.000G deskew 15
Tx: Bandwidth 16.00Gbps, Throughput 1.63Gbps (11.84%)
Rx: Bandwidth 16.00Gbps, Throughput 1.62Gbps (11.76%)
Tx+Rx: Bandwidth 32.00Gbps, Throughput 3.24Gbps (11.80%)
```

## Disabling F\_Port trunking

1. Connect to the switch and log in using an account assigned to the admin role.
2. Enter the **portDisable** command to disable the ports that are to be removed from the trunk area.
3. Enter the **portTrunkArea --disable** command to remove ports from the trunk area.

This command does not unassign a TA if its previously assigned Area\_ID is the same address identifier (Area\_ID) of the TA unless all the ports in the trunk group are specified to be unassigned.

```
switch:admin> portdisable 0-2
switch:admin> porttrunkarea --disable 0-2
Trunk index 2 disabled for ports 0, 1, and 2.
```

## Enabling the DCC policy on a trunk area

After you assign a trunk area, the **portTrunkArea** command checks whether there are any active DCC policies on the port with the index TA, and then issues a warning to add all the device WWNs to the existing DCC policy with index as TA.

All DCC policies that refer to an index that no longer exists will not be in effect.

1. Add the WWN of all the devices to the DCC policy against the TA.
2. Enter the **secPolicyActivate** command to activate the DCC policy.

In order for security to enforce the DCC policy on the trunk ports, you must enable the TA *before* issuing the **secPolicyActivate** command.

3. Turn on the trunk ports.

Turn on trunk ports *after* issuing the **secPolicyActivate** command to prevent the ports from becoming disabled in case there is a DCC security policy violation.

You can configure authentication on all Brocade trunking configurations. For more information on authentication, refer to [Configuring Security Policies](#) on page 215.

# Managing Long-Distance Fabrics

• Long-distance fabrics overview.....	483
• Extended Fabrics device limitations.....	483
• Long-distance link modes.....	484
• Configuring an extended ISL.....	484
• Forward error correction on long-distance links.....	486

## Long-distance fabrics overview

The most effective configuration for implementing long-distance SAN fabrics is to deploy Fibre Channel switches at each location in the SAN. Each switch handles local interconnectivity and multiplexes traffic across long-distance dark fiber or wave-length division multiplexing (WDM) links, while the Brocade Extended Fabrics software enables SAN management over long distances.

Brocade Extended Fabrics is an optional licensed feature for Brocade SAN deployment over distances beyond 10 km. A Brocade Extended Fabrics license is required before you can implement long-distance dynamic (LD) and long-distance static (LS) distance levels. The LD and LS settings are necessary to achieve maximum performance results over inter-switch links (ISLs) that are greater than 10 km.

For details about obtaining and installing licensed features, refer to the *Fabric OS Software Licensing Guide*.

The Extended Fabrics feature enables the following functionality:

- Fabric interconnectivity over Fibre Channel at longer distances

ISLs can use long-distance dark fiber connections to transfer data. Wavelength-division multiplexing, such as dense wavelength-division multiplexing (DWDM), coarse wavelength-division multiplexing (CWDM), and time-division multiplexing (TDM), can be used to increase the capacity of the links. As Fibre Channel speeds increase, the maximum distance decreases for each switch.

The Extended Fabrics feature extends the distance the ISLs can reach over an extended fiber. This extension is accomplished by providing enough buffer credits on each side of the link to compensate for latency introduced by the extended distance.

- Simplified management over distance

Each device attached to the SAN appears as a local device, which simplifies deployment and administration.

- Optimized switch buffering

When Extended Fabrics is installed on gateway switches (with E\_Port connectivity from one switch to another), the ISLs (E\_Ports) are configured with a large pool of buffer credits. The enhanced switch buffers help ensure that data transfer can occur at near-full bandwidth to use the connection over the extended links efficiently. This efficiency ensures the highest possible performance on ISLs.

## Extended Fabrics device limitations

Brocade recommends that you do not use the FC8-64 and FC16-64 port blades for long distance because of their limited buffers. These blades do not support long-wavelength (LWL) fiber optics and only support limited distance. However, you can use the **portCfgLongDistance** command to reserve frame buffers for the ports intended to be used in long-distance mode through DWDM.

There is a limited number of reserved buffers used for long distance for each blade. If some ports are configured in long-distance mode and have buffers reserved for them, insufficient buffers may remain for the other ports. In this case, some of the remaining ports may come up in degraded mode.

## Long-distance link modes

Use the **portCfgLongDistance** command to support long-distance links and to allocate sufficient numbers of full-size frame buffers on a specific port. Changes made by this command are persistent across switch reboots and power cycles.

The **portCfgLongDistance** command supports the following long-distance link modes:

- Normal Mode (LO) — LO is the normal (default) mode for an E\_Port. It configures the E\_Port as a standard (not long-distance) ISL. A total of 20 full-size frame buffers are reserved for data traffic, regardless of the E\_Port's operating speed. The maximum supported link distance is up to 5 km at 2 Gbps, up to 2 km at 4 Gbps, and up to 1 km at 8, 10, and 16 Gbps.
- Extended Mode (LE) — LE configures the distance for an E\_Port when that distance is greater than 5 km and up to 10 km. LE does not require an Extended Fabrics license. The baseline for the buffer credit calculation is one buffer credit per km at 2 Gbps. This allocation yields the following values for 10 km:
  - 10 buffer credits per port at 2 Gbps
  - 20 buffer credits per port at 4 Gbps
  - 40 buffer credits per port at 8 Gbps
  - 50 buffer credits per port at 10 Gbps
  - 80 buffer credits per port at 16 Gbps
  - 160 buffer credits per port at 32 Gbps
- Dynamic Mode (LD) — LD calculates buffer credits based on the distance measured during port initialization. Brocade switches use a proprietary algorithm to estimate distance across an ISL. The estimated distance is used to determine the buffer credits required in LD (dynamic) extended link mode based on a maximum Fibre Channel payload size of 2,112 bytes. You can place an upper limit on the calculation by providing a *desired\_distance* value. Fabric OS confines user entries to no larger than what it has estimated the distance to be. When the measured distance is more than the specified desired distance, the desired distance (the smaller value) is used in the calculation.
- Static Mode (LS) — LS calculates a static number of buffer credits based only on a user-defined *desired\_distance* value. LS mode also assumes that all FC payloads are 2,112 bytes. Specify LS mode to configure a static long-distance link with a fixed buffer allocation greater than 10 km.

## Configuring an extended ISL

Before configuring an extended ISL, ensure that the following conditions are met:

- The ports on both ends of the ISL are operating at the same port speed, and can be configured for the same *distance\_level* without compromising local switch performance.

### NOTE

A long-distance link also can be configured to be part of a trunk group. Two or more long-distance links in a port group form a trunk group when they are configured for the same speed and distance, and their link distances are nearly equal. For information on trunking concepts and configurations, refer to [Managing Trunking Connections](#) on page 467.

- Only qualified Brocade SFP transceivers are used. Only Brocade-branded or certain Brocade-qualified SFP transceivers are supported.
1. Connect to the switch and log in using an account assigned to the admin role.
  2. Enter the **switchDisable** command.
  3. Enter the **configure** command to set the switch fabric-wide configurations.

[Table 92](#) shows the fabric-wide settings that can be set:



**TABLE 92** Fabric-wide settings

Field	Type	Default	Range
Domain	Number	1	Varies
R_A_TOV	Number	10000	E_D_TOV * 2 to 120000
E_D_TOV	Number	2000	1000 to R_A_TOV/2
WAN_TOV	Number	0	0 to R_A_TOV/4
MAX_HOPS	Number	7	7 to 19

- For 8-Gbps platforms only, enter the **portCfgFillword** command to set ARB as the fill word. Refer to the *Fabric OS Command Reference* for more information on configuring the fill word for a single 8G FC port.

```
portcfgfillword[slot/]port, mode
```

The *mode* parameter in this command should be set to 3 if the *vc\_translation\_link\_init* parameter in the **portCfgLongDistance** command (in the next step) is set to 1.

- Enter the **portCfgLongDistance** command.

```
portcfglongdistance[slot/]port [distance_level] [vc_translation_link_init  
[-distance desired_distance]
```

- Repeat step 4 and step 5 for the remote extended ISL port. Both the local and remote extended ISL ports must be configured to the same *distance\_level*. When the connection is initiated, the fabric will reconfigure.

The following example configures slot 1, port 2 to support a 100-km link in LS mode and to use the extended link initialization sequence. This example is for an 8-Gbps platform.

```
switch:admin> portcfgfillword 1/2 3
switch:admin> portcfglongdistance 1/2 LS 1 -distance 100

Reserved Buffers =          406
Warning: port may be reserving more credits depending on port speed.
switch:admin> portshow 1/2
portName:
portHealth: OFFLINE
Authentication: None
portDisableReason: None
portCFlags: 0x1
portFlags: 0x1    PRESENT U_PORT
portType: 17.0
portState: 2     Offline
Protocol: FC
portPhys: 2     No_Module
portScn: 0
port generation number:    0
portId: 010200
portIfId: 4312003b
portWwn: 20:02:00:05:1e:94:0f:00
portWwn of device(s) connected:
Distance: static (desired = 100 Km)
portSpeed: N8Gbps
LE domain: 0
FC Fastwrite: OFF
Interrupts:      0          Link_failure: 0          Frjt:          0
Unknown:        0          Loss_of_sync: 0          Fbsy:          0
Lli:            0          Loss_of_sig: 3
Proc_rqrd:      5          Protocol_err: 0
Timed_out:      0          Invalid_word: 0
Rx_flushed:     0          Invalid_crc: 0
Tx_unavail:     0          Delim_err: 0
Free_buffer:    0          Address_err: 0
Overrun:        0          Lr_in:        0
Suspended:      0          Lr_out:       0
Parity_err:     0          Ols_in:       0
```

```

2_parity_err:    0          0ls_out:    0
CMI_bus_err:    0

```

## Enabling long distance when connecting to TDM devices

Use this procedure when connecting to time-division multiplexing (TDM) devices and your Brocade switch has QoS and buffer credit recovery enabled.

1. Connect to the switch and log in using an account assigned to the admin role.
2. Disable QoS.

```
switch:admin> portcfgqos --disable[slot/]port
```

If you do not disable QoS, after the second or third link reset (LR), ARB fill words display. Refer to the *Fabric OS Command Reference* for more information on setting fill words.

3. Disable buffer credit recovery. Buffer credit recovery is not compatible with the IDLE mode. If you do not disable buffer credit recovery, it continues to perform a link reset.

```
switch:admin> portcfgcreditrecovery --disable [slot/]port
```

4. Configure the port to support long-distance links.

```
switch:admin> portcfglongdistance [slot/]port,LS,0,-distance 100
```

## Forward error correction on long-distance links

Forward error correction (FEC) on user ports is supported for LD and LS long-distance modes. Use the **portCfgLongDistance** command with the **-fecEnable** or **-fecDisable** options to enable or disable FEC, respectively, on a user port. Alternatively, you can use the **portCfgFec** command with the **--enable** or **--disable** option as you would for any regular port.

For additional details about FEC, refer to [Forward error correction](#) on page 103.

## Enabling FEC on a long-distance link

1. Connect to the switch and log in using an account assigned to the admin role.
2. Enter the **portCfgLongDistance** command and include the **-fecEnable** option, or issue the **portCfgFec** command with the **--enable** option.
3. Enter the **portCfgFec --show** command to verify the configuration.

```

switch:admin> portcfglongdistance 1/20 LS 1 -distance 122 -fecenable
FEC has been enabled.
Reserved Buffers =          982
Warning: port (132) may be reserving more credits depending on port speed.
switch:admin> portcfgfec --show 1/20
Port: 20
FEC Capable: YES
10G/16G FEC Configured: ON
16G FEC via TTS Configured: OFF
FEC State: Inactive

```

## Disabling FEC on a long-distance link

1. Connect to the switch and log in using an account assigned to the admin role.

2. Enter the `portCfgLongDistance` command and include the `-fecDisable` option, or issue the `portCfgFec` command with the `--disable` option.
3. Enter the `portCfgFec --show` command to verify the configuration.

```
switch:admin> portcfglongdistance 1/20 LS 1 -buffers 500 -fecdisable
FEC has been disabled.
Reserved Buffers =          982
Warning: port (132) may be reserving more credits depending on port speed.
switch:admin> portcfgfec --show 1/20
Port: 20
FEC Capable: YES
10G/16G FEC Configured: OFF
16G FEC via TTS Configured: OFF
FEC State: Inactive
```



# Using FC-FC Routing to Connect Fabrics

• FC-FC routing overview.....	489
• Fibre Channel routing concepts.....	491
• Setting up FC-FC routing.....	503
• Backbone fabric IDs.....	504
• Assigning alias names to fabric IDs.....	505
• FCIP tunnel configuration.....	506
• Inter-fabric link configuration.....	506
• FC router port cost configuration.....	511
• Shortest IFL cost configuration.....	513
• EX_Port frame trunking configuration.....	518
• LSAN zone configuration.....	519
• Location embedded LSAN zones.....	532
• Peer LSAN zone support.....	536
• Proxy PID configuration.....	536
• Fabric parameter considerations.....	537
• Inter-fabric broadcast frames.....	537
• Resource monitoring.....	538
• FC-FC routing and Virtual Fabrics.....	539
• Upgrade and downgrade considerations for FC-FC routing.....	542
• Displaying the range of output ports connected to xlate domains.....	543

## FC-FC routing overview

The FC-FC routing service provides Fibre Channel routing between two or more fabrics without merging those fabrics.

For example, using FC-FC routing, you can share tape drives across multiple fabrics without the administrative problems, such as change management, network management, scalability, reliability, availability, and serviceability, that might result from merging the fabrics.

Be aware that there are different routing terminologies in use:

- *FC routing* is only in a single fabric (Layer 2 routing). This type of routing is discussed in [Routing Traffic](#) on page 107.
- *FC-FC routing* is routing between two fabrics (Layer 3 routing) and is discussed in this chapter.

FC-FC routing supports connectivity between the following types of fabrics:

- Fabric OS and Fabric OS
- Fabric OS and Brocade Network OS

A Fibre Channel router (FC router) is a switch running the FC-FC routing service. The FC-FC routing service can be simultaneously used as an FC router and as a SAN extension over wide area networks (WANs) using FCIP.

You can set up QoS traffic prioritization over FC routers. Refer to [QoS](#) on page 388 for information about QoS and instructions for setting traffic prioritization over an FC router.

## License requirements for FC-FC routing

A software license might be required for FC-FC routing, depending on the types of fabrics that are connected.

The Integrated Routing license is required for FC-FC routing between Fabric OS fabrics.

The Integrated Routing license is *not* required for connectivity between Fabric OS and Brocade Network OS fabrics or between Brocade Network OS fabrics connected by an FC router.

The Integrated Routing license allows 8-Gbps and 16-Gbps FC ports on Gen 5 platforms to be configured as EX\_Ports (or VEX\_Ports) supporting FC-FC routing.

To enable EX\_Port on the Brocade G620 switch, *Integrated Routing License* needs to be installed. To enable EX\_Port on Gen-6 32-Gbps platform switches excluding the Brocade G620 switch, *Integrated Routing Port on Demand License* needs to be installed.

Enabling the Integrated Routing license and capability does not require a switch reboot.

#### NOTE

Brocade recommends that all FC routers in a backbone fabric either have the Integrated Routing license or not. You should not mix licensed and unlicensed FC routers in the backbone fabric.

## Supported platforms for FC-FC routing

FC-FC routing is supported on the following Gen 5 (16 Gbps) Fabric OS platforms:

- Brocade 6510 switch
- Brocade 6520 switch
- Brocade 7840 Extension Switch, with the following conditions:
  - VEX\_Ports are not supported.
  - EX\_Ports are supported in the base switch.
- Brocade DCX 8510 Backbones:
  - 16-Gbps port blades (FC16-32, FC16-48, FC16-64)
  - FX8-24 extension blade
  - ICL ports on the core blades. EX-Port on ICL is supported only in DCX 8510-8 and DCX 8510-4 when all the port blades in the chassis belong to one of these blade types: FC16-32, FC16-48, FC16-64.

#### NOTE

Device discovery will not occur properly with ICL EX\_Port connected edge fabrics if the FC router has unsupported blades that are not mentioned in the previous list.

For the Brocade Backbone families, the backbones have a limit of 128 EX\_Ports for each chassis.

Refer to the *Network OS Administration Guide* for supported Network OS platforms.

FC-FC routing is supported on the following Gen 6 (32 Gbps) Fabric OS platforms:

- Brocade G620
- Brocade X6 Directors:
  - FC32-48 port blades
  - SX6 extension blade
    - > VEX\_Ports are not supported.
    - > EX\_Ports are supported.
  - ICL ports on the core blades. EX-Port on ICL is supported only in X6-8 and X6-4 when all the port blades in the chassis are FC32-48.

#### NOTE

Boot from SAN FCR is not a supported if devices are not imported in the backbone.

## Supported configurations for FC-FC routing

FC-FC routing supports the following configurations:

- FC router connected to a Fabric OS nonsecured edge fabric.
- FC router connected to a Fabric OS secured edge fabric.
- FC router connected to a Brocade Network OS edge fabric (Refer to the Release Notes for the supported Network OS version).
- FC router interoperating with legacy FC routers (Brocade 7500 switch).

In configurations with two backbone fabrics connected to the same edge fabric, routing is not supported between edge fabrics that are not directly attached to the same backbone fabric. Routing over multiple backbone fabrics is a multi-hop topology and is not allowed.

VEX edge to VEX edge device sharing is not supported.

### NOTE

When there are multiple EX or VEX ports between edge and backbone fabric they will be considered equal cost routes. FSPF does not apply from edge to edge. This needs to be taken into consideration when designing FCR fabrics.

## Network OS connectivity limitations

You should be aware of the following configuration limitations for Network OS connectivity:

- All of the platforms listed in [Supported platforms for FC-FC routing](#) on page 490 support FC-FC routing to a Brocade Network OS fabric, except for the Brocade Encryption Switch.
- VEX\_Ports do not support Network OS connectivity.

## Fibre Channel routing concepts

Fibre Channel routing introduces the following concepts:

- Fibre Channel router (FC router)

A switch running the FC-FC routing service. Refer to [Supported platforms for FC-FC routing](#) on page 490 for a list of platforms that can be FC routers.

- Backbone fabric

A backbone fabric is an intermediate network that connects one or more edge fabrics. In a SAN, the backbone fabric consists of at least one FC router and possibly a number of Fabric OS-based Fibre Channel switches (refer to [Figure 77](#)).

- Inter-fabric link (IFL)

The link between an E\_Port and EX\_Port, or VE\_Port and VEX\_Port, is called an *inter-fabric link* (IFL). You can configure multiple IFLs from an FC router to an edge fabric.

[Figure 75](#) shows a metaSAN consisting of three edge fabrics connected through a Brocade DCX with inter-fabric links.

FIGURE 75 A metaSAN with inter-fabric links

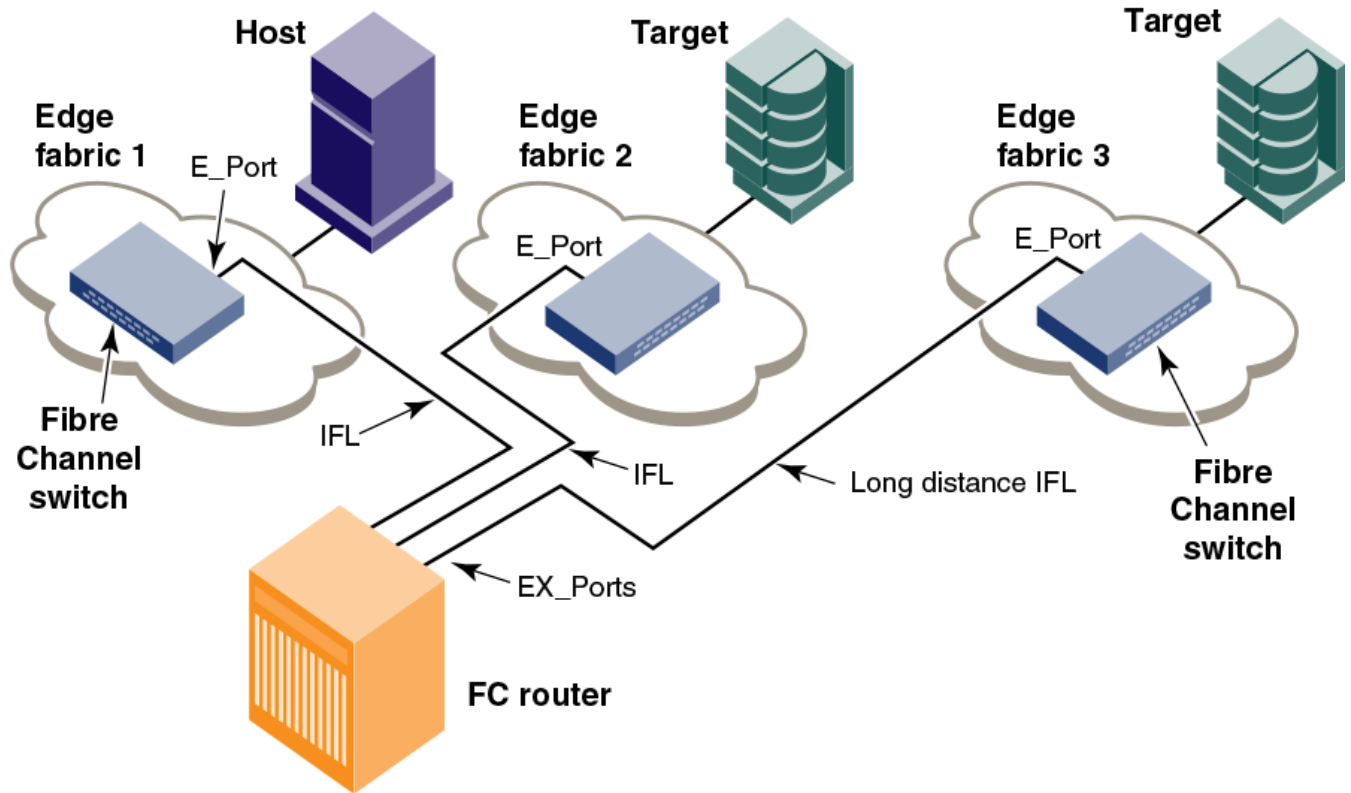

- EX\_Port and VEX\_Port

An EX\_Port and VEX\_Port function similarly to an E\_Port and VE\_Port respectively, but terminate at the switch and do not propagate fabric services or routing topology information from one edge fabric to another. Refer to the *Fabric OS FCIP Administrator's Guide* for details about VE\_Ports.

- Edge fabric

An edge fabric is a Fibre Channel fabric with targets and initiators connected through the supported platforms.

- Logical SANs (LSANs)

An LSAN is defined by zones in two or more edge or backbone fabrics that contain the same devices. You can create LSANs that span fabrics. These LSANs enable Fibre Channel zones to cross physical SAN boundaries without merging the fabrics while maintaining the access controls of zones.

An LSAN device can be a *physical device*, meaning that it physically exists in the fabric, or it can be a *proxy device*.

Figure 76 shows a metaSAN with a backbone consisting of one FC router connecting hosts in edge fabrics 1 and 3 with storage in edge fabric 2 and the backbone fabric through the use of LSANs. Three LSAN zones allow device sharing between the backbone fabric and edge fabric 1, between edge fabric 1 and edge fabric 2, and between edge fabric 2 and edge fabric 3.



FIGURE 76 A metaSAN with edge-to-edge and backbone fabrics and LSAN zones

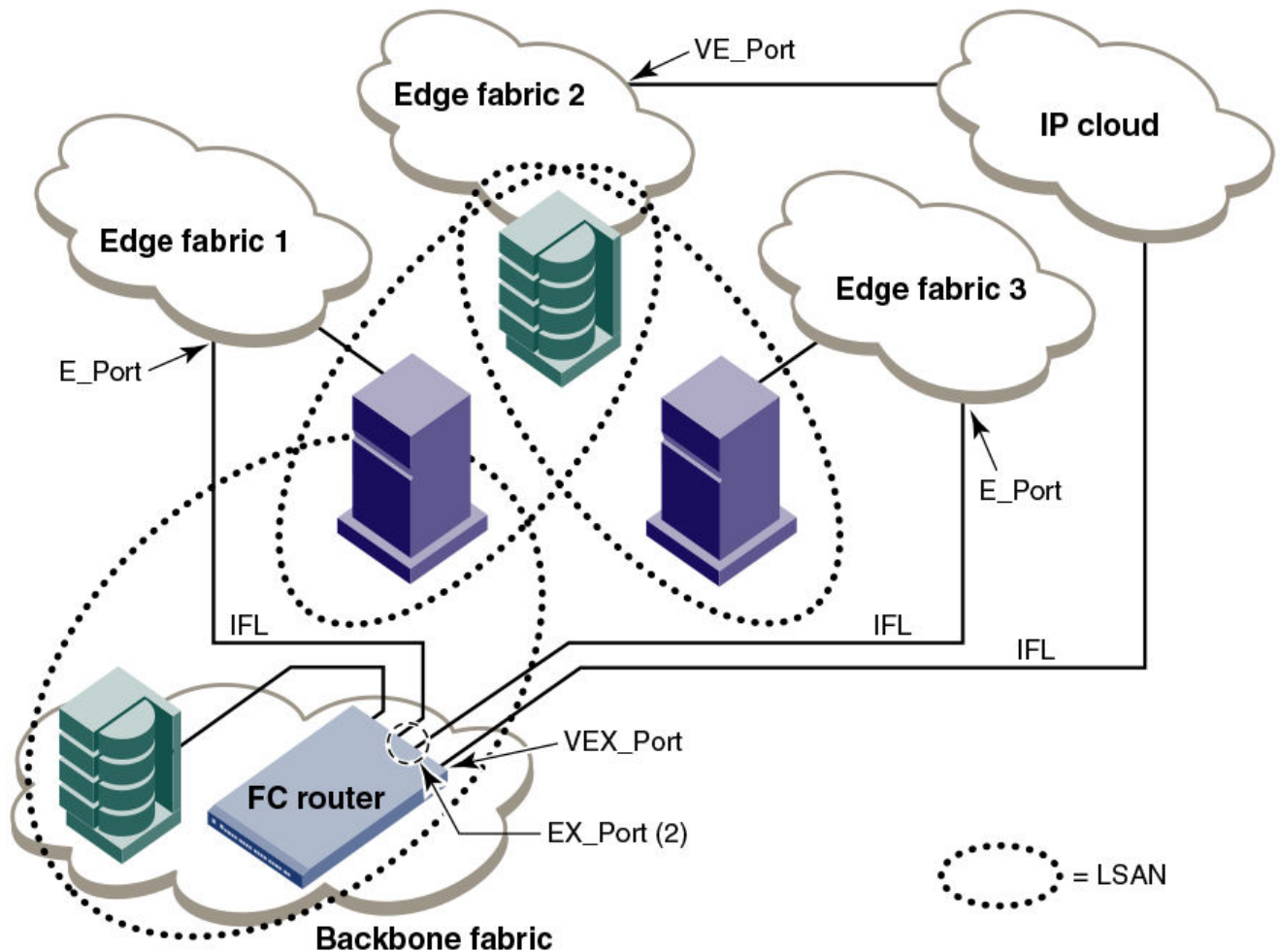

- Proxy device

A proxy device is a virtual device imported into a fabric by a Fibre Channel router, and represents a real device on another fabric. It has a name server entry and is assigned a valid port ID. When a proxy device is created in a fabric, the real Fibre Channel device is considered to be imported into this fabric. The presence of a proxy device is required for inter-fabric device communication. Refer to [Proxy devices](#) on page 496 for additional information about proxy devices.

- Proxy PID

A proxy PID is the port ID (PID) of the proxy device. The proxy device appears to the fabric as a real Fibre Channel device, has a name server entry, and is assigned a valid port ID. The port ID is relevant only on the fabric in which the proxy device has been created.

- Fabric ID (FID)

Every EX\_Port and VEX\_Port uses the fabric ID (FID) to identify the fabric at the opposite end of the inter-fabric link. The FID for every edge fabric must be unique from the perspective of each backbone fabric.

- If multiple EX\_Ports (or multiple VEX\_Ports) are attached to the same edge fabric, they must be configured with the same FID.

- If EX\_Ports and VEX\_Ports are attached to different edge fabrics, they must be configured with a unique FID for each edge fabric.

**NOTE**

Backbone fabrics that share connections to the same edge fabrics must have unique backbone fabric IDs.

If two different backbone fabrics are connected to the same edge fabric, the backbone fabric IDs must be different, but the edge fabric IDs must be the same. If you configure the same fabric ID for two backbone fabrics that are connected to the same edge fabric, a RASLog message displays a warning about fabric ID overlap.

You can optionally assign an alias name to the FID.

- MetaSAN

A metaSAN is the collection of all SANs interconnected with Fibre Channel routers.

A simple metaSAN can be constructed using an FC router to connect two or more separate fabrics. Additional FC routers can be used to increase the available bandwidth between fabrics and to provide redundancy.

[Figure 77](#) shows a metaSAN consisting of a host in Edge SAN 1 connected to storage in Edge SAN 2 through a backbone fabric connecting two FC routers.

FIGURE 77 Edge SANs connected through a backbone fabric

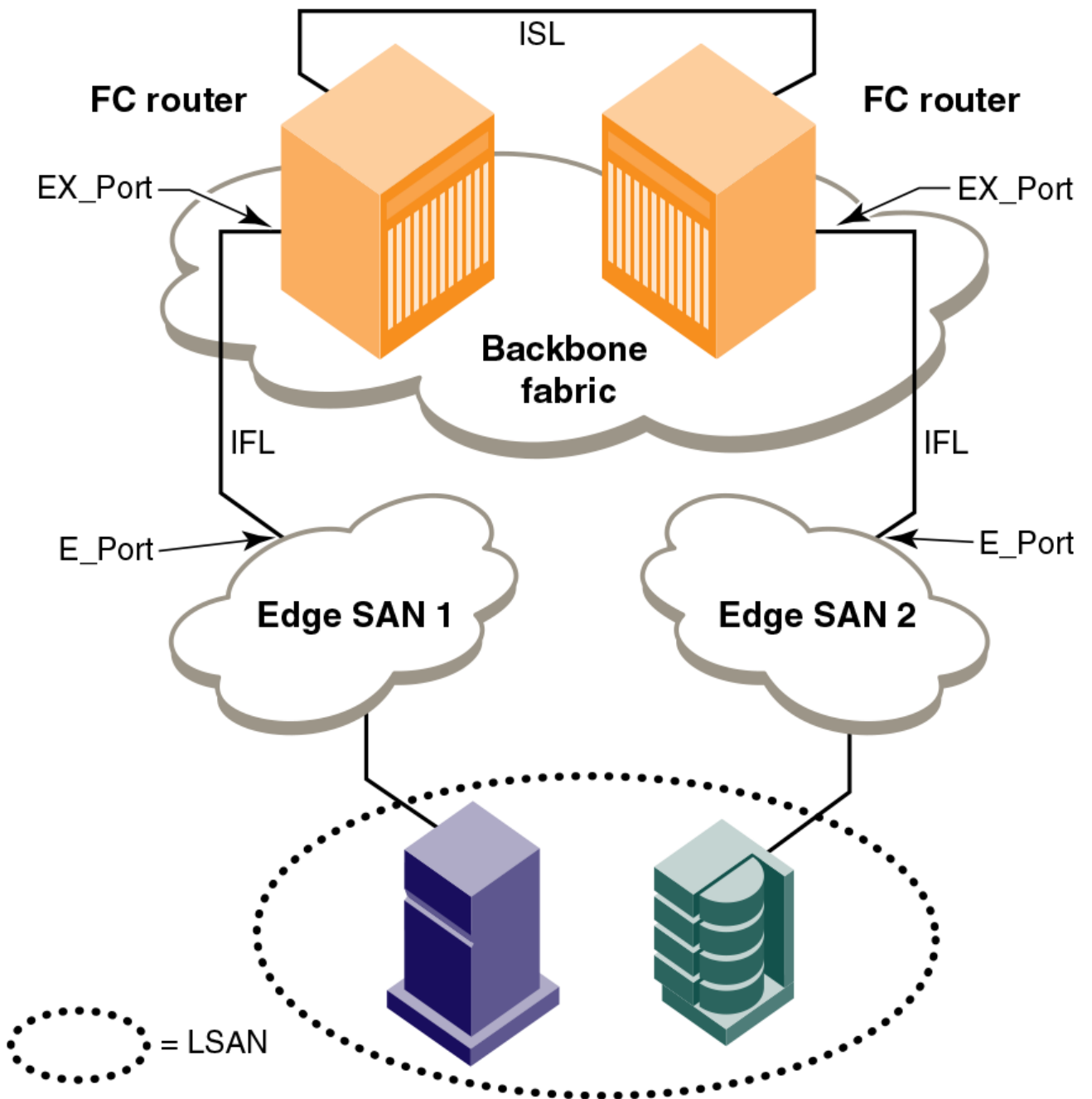

- Phantom domains

A phantom domain is a domain emulated by the Fibre Channel router. The FC router can emulate two types of phantom domains: front phantom domains and translate phantom domains. For detailed information about phantom domains, refer to [Phantom domains](#) on page 497.

## Proxy devices

An FC router achieves inter-fabric device connectivity by creating proxy devices (hosts and targets) in attached fabrics that represent real devices in other fabrics.

For example, a host in Fabric 1 can communicate with a target in Fabric 2 as follows:

- A proxy target in Fabric 1 represents the real target in Fabric 2.
- Likewise, a proxy host in Fabric 2 represents the real host in Fabric 1.

The host discovers and sends Fibre Channel frames to the proxy target. The FC router receives these frames, translates them appropriately, and then delivers them to the destination fabric for delivery to the target.

The target responds by sending frames to the proxy host. Hosts and targets are exported from the edge SAN to which they are attached and, correspondingly, imported into the edge SAN reached through Fibre Channel routing. The following figure illustrates this concept.

FIGURE 78 MetaSAN with imported devices

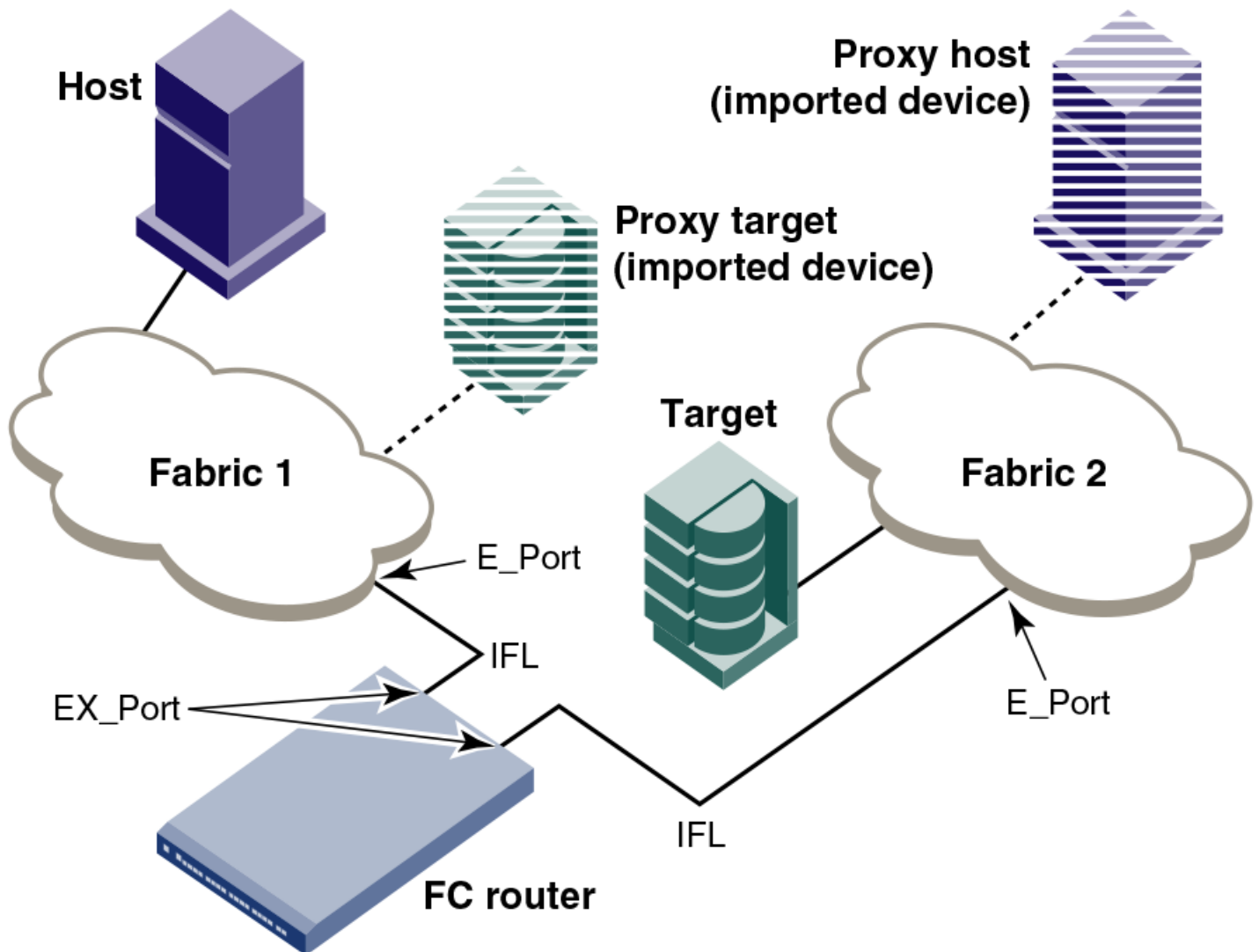

## FC-FC routing topologies

The FC-FC routing service provides two types of routing:

- *Edge-to-edge*: Occurs when devices in one edge fabric communicate with devices in another edge fabric through one or more FC routers.
- *Backbone-to-edge*: Occurs when devices in the FC routers communicate with devices in an edge fabric--known as a *backbone fabric*--through E\_Ports.

A backbone fabric can be used as a transport fabric that interconnects edge fabrics. FC routers also enable hosts and targets in edge fabrics to communicate with devices in the backbone fabric, known as *backbone-to-edge routing*. From the perspective of the edge fabric, the backbone fabric is like any other edge fabric. For the edge fabric and backbone fabric devices to communicate, the shared devices must be presented to each other's native fabric.

To do so, at least one translate phantom domain is created in the backbone fabric. This translate phantom domain represents the entire edge fabric. The shared physical devices in the edge have corresponding proxy devices on the translate phantom domain.

Each edge fabric has one and only one translate phantom domain to the backbone fabric. The backbone fabric device communicates with the proxy devices whenever it needs to contact the shared physical devices in the edge. The FC-FC routing service receives the frames from the backbone switches destined to the proxy devices, and redirects the frames to the actual physical devices. When connected to edge fabrics, the translate phantom domain can never be the principal switch of the backbone fabric. Front domains are not created, only translate phantom domains are created in the backbone fabric.

Devices are exported from the backbone fabric to one or more edge fabrics using LSANs. Refer to [LSAN zone configuration](#) on page 519 for more information.

## Phantom domains

A phantom domain is a domain created by the Fibre Channel router. The FC router creates two types of phantom domains: front phantom domains and translate phantom domains.

A *front phantom domain*, or *front domain*, is a domain that is projected from the FC router to the edge fabric. There is one front phantom domain from each FC router to an edge fabric, regardless of the number of EX\_Ports connected from that router to the edge fabric. Another FC router connected to the same edge fabric projects a different front phantom domain.

A *translate phantom domain*, also referred to as *translate domain* or *xlate domain*, is a router virtual domain that represents an entire fabric. The EX\_Ports present xlate domains in edge fabrics as being topologically behind the front domains; if the xlate domain is in a backbone fabric, then it is topologically present behind the FC router because there is no front domain in a backbone fabric.

If an FC router is attached to an edge fabric using an EX\_Port, it creates xlate domains in the fabric corresponding to the imported edge fabrics with active LSANs defined. If you import devices into the backbone fabric, then an xlate domain is created in the backbone device in addition to the one in the edge fabric.

[Figure 79](#) shows a sample physical topology. This figure shows four FC routers in a backbone fabric and four edge fabrics connected to the FC routers.

FIGURE 79 Sample topology (physical topology)

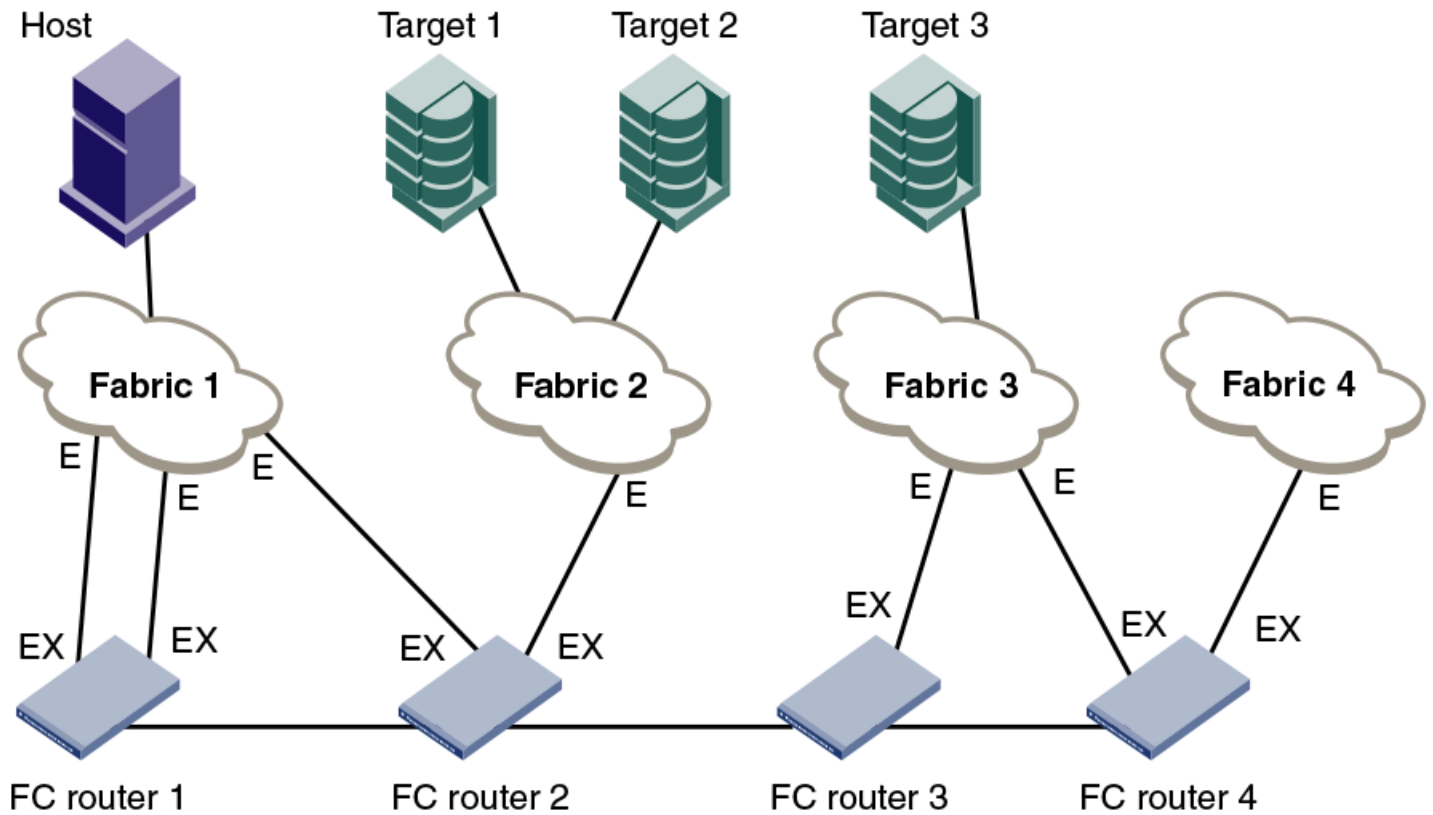
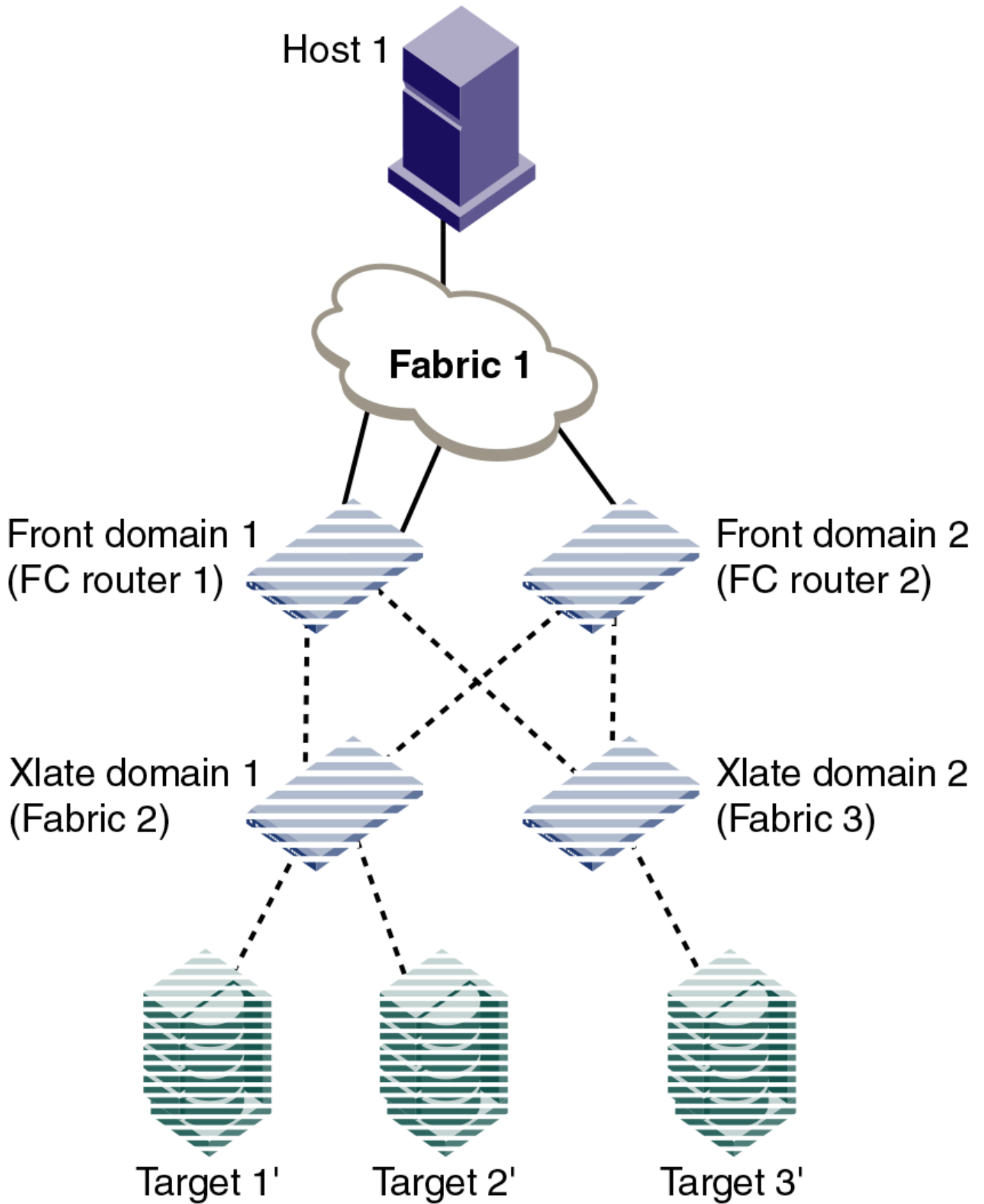

Figure 80 shows a phantom topology for the physical topology shown in Figure 79. In this figure, the dashed lines and shapes represent the phantom topology from the perspective of Fabric 1. Fabrics 2 and 3 also see phantom topologies, but they are not shown in this example. In this figure, note the following:

- Front domain 1 and Front domain 2 are front domains for EX\_Ports connecting to Fabric 1. There is one front domain for each FC router that is connected to Fabric 1.
- Xlate domain 1 and Xlate domain 2 represent Fabrics 2 and 3, respectively. No xlate domain is created for Fabric 4 because there are no LSAN devices in Fabric 4.
- Target 1', Target 2', and Target 3' are proxy devices for Target 1, Target 2, and Target 3, respectively.

**FIGURE 80** EX\_Port phantom switch topology





All EX\_Ports or VEX\_Ports connected to an edge fabric use the same xlate domain ID for an imported edge fabric; this value persists across switch reboots and fabric reconfigurations.

If you lose connectivity to the edge fabric because of link failures or the IFL being disabled, xlate domains remain visible. This prevents unnecessary fabric disruptions caused by xlate domains repeatedly going offline and online due to corresponding IFL failures. To remove the xlate domain from the backbone, refer to [Identifying and deleting stale xlate domains](#) on page 501.

The combination of front domains and xlate domains allows routing around path failures, including path failures through the routers. The multiple paths to an xlate domain provide additional bandwidth and redundancy.

There are some differences in how the xlate domain is presented in the backbone fabric. The backbone xlate domains are topologically connected to FC routers and participate in FC-FC routing protocol in the backbone fabric. Front domains are not needed in the backbone fabric. As in the case of an xlate domain in an edge fabric, backbone fabric xlate domains provide additional bandwidth and redundancy by being able to present themselves as connected to single or multiple FC routers with each FC router capable of connecting multiple IFLs to edge fabrics.

Use the **fcrXlateConfig** command to display or assign a preferred domain ID to a translate domain or, in some scenarios, to prevent the creation of an unnecessary xlate domain.

## Identifying and deleting stale xlate domains

If a remote edge fabric goes unreachable, the xlate domains created in other edge fabrics for this remote edge fabric are retained and not removed unless there is any disruption in the local edge fabric or unless you remove them manually.

You can use the **fcrXlateConfig** command to identify and remove these stale xlate domains without disrupting the fabric.

1. Connect to the FC router and log in using an account with admin permissions.
2. Enter the **fcrXlateConfig --show** command to identify any stale xlate domains.
3. Enter the **fcrXlateConfig --del** command to delete the stale xlate domains.

```
sw0:root> fcrxlateconfig --show stalexd
Imported FID      Stale XD      Owner Domain
-----
      012          002          007 ( this FCR )
sw0:root> fcrxlateconfig --del stalexd 12 2
Xlate domain 2 is deleted
```

## Domain ID range for front and translate phantom domains

In the releases prior to Fabric OS 7.4.0, the following domain IDs were assigned:

- The FC router front domain is assigned 160 as the domain ID if the insistent domain ID is not configured using the **portCfgExport** command.
- The FC router translate domain is assigned 1 as the domain ID for importing proxies to the edge fabric if the insistent domain ID is not configured using the **fcrXlateConfig** command.

Starting with Fabric OS 7.4.0, to avoid FC router phantom domains taking over the real switch domain ID, the principal switch assigns the domain ID based on the following rules:

- The front domain ID for an FC router is assigned within the range 160 through 199.
- The translate domain ID for an FC router is assigned within the range 200 through 239
- If the preferred domain ID is not configured on an FC router for front or translate domain, the FC router requests 160 for the front domain and 200 for the translate domain. If the preferred domain ID is configured on the FC router for either the front or translate domain, the FC router will still request for the front domain ID of 160 and the translate domain ID of 200 at the discretion of the principal switch in the edge fabric. Depending on whether there are any domain ID conflicts in the fabric,

switches can either be merged with the fabric using a different domain ID (front or translate domain ID) or they are segmented from the fabric.

- If preferred domain ID is configured on an FC router for front and/or translate domain, the FC router requests the preferred domain ID. Phantom domain IDs are stored persistently and used in RDI request. To utilize the new range (160 to 239), do one of the following tasks:

**Option 1:**

1. Convert the EX\_Port to non-FC router port remove existing Xlate configuration using the **fcrXlateConfig** command.
2. Apply the default configuration, and then configure the EX\_Ports again and remove existing Xlate configuration using the **fcrXlateConfig** command..

**Option 2:**

1. Disable all EX\_Ports in the same edge fabric and persistent XD feature, and then reset the persistent phantom domain using the **fcrConfigure --resetPhantomDomain** command.

```
switch:admin> fcrconfigure --resetphantomdomain
This operation will reset all the phantom domain to be default range
Do you want to continue (Y/N):y
Phantom Domain IDs were successfully reset to default range
```

Using the **-force** option to force the reset phantom domain.

```
switch:admin> fcrconfigure -resetphantomdomain -force
Phantom Domain IDs were successfully reset to default range
```

2. Enable all the EX\_Ports.

**TABLE 93** Front and translate domain IDs

Firmware version in FC router	Front domain ID requested	Translate domain ID requested
Prior to Fabric OS 7.4.0	160	1
Fabric OS 7.4.0 and later	160	200

When an FC router is running Fabric OS 7.4.0 and the edge FC router is running Fabric OS 7.3.0, or vice versa, you need to use a different FID to reconstruct the EX\_Ports or disable the EX\_Port or use the **fcrXlateConfig** command to delete the stale translate domains when moving from Fabric OS 7.3.0 to Fabric OS 7.4.0 as the old translate domains are still in effect.

## FC router authentication

A Brocade FC router is capable of forming a secure link across fabrics. The EX\_Port-enabled router exchanges DH-CHAP information with the edge fabric to enable authentication.

Note that while setting secret keys in the edge switch, the front phantom WWN should be used as the remote switch WWN in the edge fabric. The front phantom domain's WWN is available through the **portCfgExport** command of the EX\_Port connecting to the edge fabric. The FC router switch should use the edge switch's WWN to configure the secret keys. Refer to [Secret key pairs for DH-CHAP](#) on page 232 for more details.

FC-FC routing behaves passively to the authentication requests received from edge fabric switches. An FC router never initiates authentication on an EX\_Port and only responds to the edge fabric requests.

**NOTE**

Changing the switch authentication policy mode does not affect online EX\_Ports, so it is acceptable to leave the default Passive policy configured on the FC router while the Active or On policy is required on the edge switch.

## Setting up FC-FC routing

To set up FC-FC routing, perform the following tasks in the order listed.

1. Verify that you have the proper setup for FC-FC routing. (Refer to [Verifying the setup for FC-FC routing](#) on page 503.)
2. Assign backbone fabric IDs. (Refer to [Backbone fabric IDs](#) on page 504.)
3. Configure FCIP tunnels if you are connecting Fibre Channel SANs over IP-based networks.
4. Configure IFLs for edge and backbone fabric connection. (Refer to [Inter-fabric link configuration](#) on page 506.)
5. Modify port cost for EX\_Ports, if you want to change from the default settings. (Refer to [FC router port cost configuration](#) on page 511.)
6. Enable shortest IFL mode if you want to choose a lowest cost IFL path in the backbone fabric. (Refer to [Shortest IFL cost configuration](#) on page 513.)
7. Configure trunking on EX\_Ports that are connected to the same edge fabric. (Refer to [EX\\_Port frame trunking configuration](#) on page 518.)
8. Configure LSAN zones to enable communication between devices in different fabrics. (Refer to [LSAN zone configuration](#) on page 519.)

Refer to [Performing Advanced Configuration Tasks](#) on page 69 for more details about configuration options for Brocade Backbones.

## Verifying the setup for FC-FC routing

Before configuring a fabric to connect to another fabric, you must perform verification checks on the FC router.

1. Log in to the FC router as admin and enter the **version** command. Verify that Fabric OS v7.3.0 or later is installed on the FC router, as shown in the following example.

```
switch:admin> version
Kernel:      2.6.14.2
Fabric OS:   v7.3.0
Made on:     Fri Feb 21 01:15:34 2014
Flash:      Wed Feb 26 20:53:48 2014
BootProm:   1.0.11
```

2. If you are configuring a Brocade DCX 8510 Backbone, enter the **slotShow** command to verify that an FX8-24 blade is present or 16-Gbps port blade is present. The following example shows slots 1, 2, 3, 4, 9, 10, and 12 with 16-Gbps port blades enabled.

```
switch:admin> slotshow -m
Slot  Blade Type      ID      Model Name      Status
-----
  1    SW BLADE           96      FC16-48         ENABLED
  2    SW BLADE           96      FC16-48         ENABLED
  3    SW BLADE           96      FC16-48         ENABLED
  4    SW BLADE           96      FC16-48         ENABLED
  5    CORE BLADE         98      CR16-8          ENABLED
  6    CP BLADE           50      CP8             ENABLED
  7    CP BLADE           50      CP8             ENABLED
  8    CORE BLADE         98      CR16-8          ENABLED
  9    SW BLADE           96      FC16-48         ENABLED
 10    SW BLADE           96      FC16-48         ENABLED
 11    UNKNOWN
 12    SW BLADE           96      FC16-48         ENABLED
```

Refer to [Performing Advanced Configuration Tasks](#) on page 69 for a list of blades and their corresponding IDs.

3. Enter the **licenseShow** command to verify that the Integrated Routing license is installed.

```
switch:admin> licenseshow
S9bddb9SQbTAcceCbzbzRcbcSc0c0SYRyeSzRSscycazfT0G:
```

```
Integrated Routing Ports on Demand license
Capacity 128
```

If you are connecting to a Fabric OS and the Integrated Routing license is not installed, you must install it, as described in the *Fabric OS Software Licensing Guide*. The Integrated Routing license is not required if you are connecting to a Brocade Network OS fabric.

For configuring EX\_Ports on an ICL, both the Integrated Routing license and the ICL POD license are required.

4. If all switches in the fabric are running Fabric OS 7.3.0 or later, skip this step. If any switch is running a Fabric OS version earlier than 7.3.0, then enter the `fddCfg --showall` command to verify that the Fabric-Wide Consistency Policy is not in "strict" mode.

When it is in strict mode, an ACL cannot support Fibre Channel routing in the fabric.

```
switch:admin> fddcfg --showall
Local Switch Configuration for all Databases:-
  DATABASE - Accept/Reject
-----
      SCC -      accept
      DCC -      accept
      PWD -      accept
      FCS -      accept
      AUTH -     accept

Fabric-Wide Consistency Policy :- "SCC:S;DCC"
```

If the Fabric-Wide Consistency Policy has the letter "S" in it in the edge fabric or the backbone fabric, do not connect the edge fabric to the FC router. The letter "S" (shown in the preceding sample output) indicates the policy is strict. The Fabric-Wide Consistency Policy must be tolerant before you can connect fabrics to the FC router. Refer to [Configuring Security Policies](#) on page 215 for information about configuring the Fabric-Wide Consistency Policy.

5. For 8-Gbps platforms, delete fabric mode Top Talker monitors, if they are configured.

FC-FC routing and fabric mode Top Talker monitors are not concurrently supported on 8-Gbps platforms.

FC-FC routing and fabric mode Top Talker monitors are concurrently supported only on the Brocade 6510 and 6520 switches, and on the Brocade DCX Backbone family with only 16-Gbps capable ports.

## Backbone fabric IDs

If your configuration has only one backbone fabric, then you do not need to assign a backbone fabric ID because the backbone fabric ID in this situation defaults to a value of 128. The default backbone fabric ID is 1 if Virtual Fabrics is disabled.

All switches in a backbone fabric must have the same backbone fabric ID. You can configure the backbone fabric ID using the `fcrConfigure` command. The backbone fabric ID must be unique from the perspective of every attached edge fabric. Fabric ID changes made on a switch are not propagated to other switches in the backbone fabric. The backbone fabric administrator is responsible for making sure that all switches in the backbone have the same fabric ID. Because fabric IDs are used heavily by the routing protocol between the Fibre Channel routers, using the wrong fabric ID can affect both edge-to-edge and backbone-to-edge routing.

In addition to ensuring that the backbone fabric IDs are the same within the same backbone, you must make sure that when two different backbones are connected to the same edge fabric, the backbone fabric IDs are different, but the edge fabric ID should be the same. Configuration of two backbones with the same backbone fabric ID that are connected to the same edge is invalid. In this configuration, a RASLog message displays a warning about fabric ID overlap. When two backbone fabrics are *not* connected to the same edge, they can have the same backbone fabric ID.

### ATTENTION

In a multi-switch backbone fabric, modification of the FID within the backbone fabric will cause disruption to local traffic.

## Assigning backbone fabric IDs

1. Log in to the switch or backbone.
2. Enter the **switchDisable** command if EX\_Ports are online.
3. Enter the **fosConfig --disable fcr** command to disable the FC-FC routing service.  
The default state for the FC router is disabled.
4. Enter the **fcrConfigure --bbfid** command. At the prompt, enter the fabric ID, or press **Enter** to keep the current fabric ID, which is displayed in brackets.
5. Verify the backbone fabric ID is different from that set for edge fabrics.  
Multiple FC routers attached to the same backbone fabric must have the same backbone fabric ID.
6. Enter the **fosConfig --enable fcr** command.
7. Enter the **switchEnable** command.

```
switch:admin> switchdisable
switch:admin> fosconfig --disable fcr
FC Router service is disabled
switch:admin> fcrconfigure --bbfid
FC Router parameter set. <cr> to skip a parameter
Please make sure new Backbone Fabric ID does not conflict with any configured EX-Port's Fabric ID
Backbone fabric ID: (1-128)[128]
switch:admin> fosconfig --enable fcr
FC Router service is enabled
switch:admin> switchenable
```

## Assigning alias names to fabric IDs

You can assign an alias name to each fabric ID for easier configuration and manageability.

The alias name is a user friendly name that you can use instead of a fabric ID (FID) in the **portcfgexport** and **portcfgvexport** commands.

There is no relation between the FID alias name and the fabric name, which you configure with the **fabricname** command.

1. Log in to the switch or backbone.
2. Set the FID alias using the **fcrconfigure --add** command.  

```
fcrconfigure --add -alias alias_name -fid fid
```
3. Verify the configured alias names using the **fcrconfigure --show -alias** command.

```
fcrconfigure --show -alias
```

The following example configures alias names for three fabrics, and then configures an EX\_Port using the FID alias name.

```
switch:admin> fcrconfigure --add -alias Green_fabric -fid 10
switch:admin> fcrconfigure --add -alias Blue_fabric -fid 12
switch:admin> fcrconfigure --add -alias Yellow_fabric -fid 15
switch:admin> fcrconfigure --show -alias
  FID      Alias
  =====
  10       Green_fabric
  12       Blue_fabric
  15       Yellow_fabric

switch:admin> portcfgexport 3 -a 1 -f Green_fabric; portenable 3
switch:admin> portcfgexport 3
Port 3 info
Admin:                enabled
State:                OK
Pid format:           core(N)
Operate mode:         Brocade Native
Edge Fabric ID:       10
Alias Name:            Green_fabric
Front Domain ID:      5
(output truncated)
```

## FCIP tunnel configuration

The optional Fibre Channel over IP (FCIP) Tunneling Service enables you to use tunnels to connect instances of Fibre Channel SANs over IP-based networks to transport all Fibre Channel ISL and IFL traffic. FCIP is a prerequisite for configuring VEX\_Ports. If you are only using FC\_Ports, then there is no need to configure FCIP tunnels.

If using FCIP in your FC-FC routing configuration, you must first configure FCIP tunnels. Once a tunnel is created, it defaults to a disabled state. Then configure the VE\_Port or VEX\_Port. After the appropriate ports are configured, enable the tunnel.

### NOTE

FCIP tunnel configuration is applicable only to Fabric OS fabrics and does not apply to Brocade Network OS fabrics.

Refer to the *Fabric OS FCIP Administrator's Guide* for instructions on how to configure FCIP tunnels.

## Inter-fabric link configuration

Configuring an inter-fabric link (IFL) involves disabling ports and cabling them to other fabrics, configuring those ports for their intended uses, and then enabling the ports.

Before configuring an inter-fabric link, be aware that you cannot configure both IFLs (EX\_Ports, VEX\_Ports) and ISLs (E\_Ports) from a backbone fabric to the same edge fabric.

### ATTENTION

To ensure that fabrics remain isolated, disable the port prior to inserting the cable. If you are configuring an EX\_Port, disable the port prior to making the connection.

## Configuring an IFL for both edge and backbone connections

1. On the FC router, disable the port that you are configuring as an EX\_Port (the one connected to the Fabric OS switch) by issuing the **portDisable** command.

```
switch:admin> portdisable 7/10
```

You can verify that the port has been disabled by issuing the **portShow** command for the port.

2. Configure each port that connects to an edge fabric as an EX\_Port or VEX\_Port using either the **portCfgVEXPort** or **portCfgEXPort** command.
  - **portCfgVEXPort** works only on VE\_Ports.
  - **portCfgEXPort** (only on the FC ports on the FC router) commands work only on ports that are capable of FC-FC routing.

The following example configures an EX\_Port and assigns a Fabric ID of 30 to port 10.

```
switch:admin> portcfgexport 7/10 -a 1 -f 30
switch:admin> portcfgexport 7/10
Port 7/10 info
Admin: enabled
State: OK
Pid format: Not Applicable
Operate mode: Brocade Native
Edge Fabric ID: 30
Preferred Domain ID: 160
Front WWN: 50:06:06:9e:20:38:6e:1e
Fabric Parameters: Auto Negotiate
R_A_TOV: Not Applicable
E_D_TOV: Not Applicable
Authentication Type: None
DH Group: N/A
Hash Algorithm: N/A
Edge fabric's primary wwn: N/A
Edge fabric's version stamp: N/A
```

This port can now connect to another switch.

The following example configures an EX\_Port for connecting to a Brocade Network OS fabric. The **-m 5** option indicates Network OS connectivity.

```
switch:admin> portcfgexport 1/5 -a 1 -f 15 -m 5
switch:admin> portcfgexport 1/5
Port 1/5 info
Admin: enabled
State: OK
Pid format: Not Applicable
Operate mode: Brocade NOS
Edge Fabric ID: 15
(output truncated)
```

The following example shows configuring a port range:

```
DCX:root> portcfgexport 1/1-2 -a 1
2014/09/15-07:09:12, [FCR-1071], 11763, SLOT 6 | FID 128, INFO, DCX, Port 1/1 is changed from non
FCR port to FCR port.
2014/09/15-07:09:13, [FCR-1071], 11764, SLOT 6 | FID 128, INFO, DCX, Port 1/2 is changed from non
FCR port to FCR port.
```

For related FC-FC routing commands, refer to **fcrEdgeShow**, **fcrXlateConfig**, **fcrConfigure**, and **fcrProxyConfig** in the *Fabric OS Command Reference*.

A Fibre Channel router can interconnect multiple fabrics. EX\_Ports or VEX\_Ports attached to more than one edge fabric must configure a different fabric ID for each edge fabric.

3. (Optional) Configure FC router port cost if you want to change the default values. For information about using FC router port cost operations, refer to [FC router port cost configuration](#) on page 511.
4. (Optional) Set up ISL or EX\_Port trunking. For information on trunking setup, refer to [Configuring EX\\_Port trunking](#) on page 475.
5. Physically attach ISLs from the Fibre Channel router to the edge fabric.
6. Enter the **portEnable** command to enable the ports that you disabled in step 1.

```
switch:admin> portenable 7/10
```

7. Enter the **portCfgShow** command to view ports that are persistently disabled.

FC ports on the Brocade 7800 and 7840 switches and FX8-24 blades are configured as persistently disabled by default to avoid inadvertent fabric merges when installing a new FC router.

```
switch:admin> portcfgshow 7/10
Area Number:          74
Speed Level:          AUTO
Trunk Port            OFF
Long Distance        OFF
VC Link Init         OFF
Locked L_Port        OFF
Locked G_Port        OFF
Disabled E_Port      OFF
ISL R_RDY Mode       OFF
RSCN Suppressed      OFF
Persistent Disable    OFF
NPIV capability      ON
EX Port              ON
Mirror Port          ON
FC Fastwrite         ON
```

8. After identifying such ports, enter the **portCfgPersistentEnable** command to enable the port, and then the **portCfgShow** command to verify the port is enabled.

```
switch:admin> portcfgpersistentenable 7/10
switch:admin> portcfgshow 7/10
Area Number:          74
Speed Level:          AUTO
Trunk Port            OFF
Long Distance        OFF
VC Link Init         OFF
Locked L_Port        OFF
Locked G_Port        OFF
Disabled E_Port      OFF
ISL R_RDY Mode       OFF
RSCN Suppressed      OFF
Persistent Disable    OFF
NPIV capability      ON
EX Port              ON
Mirror Port          ON
FC Fastwrite         ON
```

9. Enter either the **portCfgEXPort** or **portShow** command to verify that each port is configured correctly.

```
switch:admin> portcfgexport 7/10
Port 7/10 info
Admin:                enabled
State:                OK
Pid format:           Not Applicable
Operate mode:         Brocade Native
Edge Fabric ID:       30
Preferred Domain ID: 160
Front WWN:            50:06:06:9e:20:38:6e:1e
Fabric Parameters:    Auto Negotiate
R_A_TOV:              Not Applicable
E_D_TOV:              Not Applicable
Authentication Type:  None
DH Group: N/A
Hash Algorithm: N/A
Edge fabric's primary wwn: N/A
Edge fabric's version stamp: N/A
switch:admin_06> portshow 7/10
portName:
portHealth: OFFLINE
Authentication: None
EX_Port Mode: Enabled
Fabric ID: 30
Front Phantom: state = Not OK Pref Dom ID: 160
```



```

Fabric params:  R_A_TOV: 0      E_D_TOV: 0      PID fmt: auto
Authentication Type: None
Hash Algorithm: N/A
DH Group: N/A
Edge fabric's primary wwn: N/A
Edge fabric's version stamp: N/A
portDisableReason: None
portCFlags: 0x1
portFlags: 0x1  PRESENT U_PORT EX_PORT
portType: 10.0
portState: 2  Offline
portPhys: 2  No_Module
portScn: 0
port generation number: 0
portId: 014a00
portIfId: 4372080f
portWwn: 20:4a:00:60:69:e2:03:86
portWwn of device(s) connected:
Distance: normal
portSpeed: N4Gbps
LE domain: 0
FC Fastwrite: ON
Interrupts:      0      Link_failure: 0      Frjt :      0
Unknown:         0      Loss_of_sync: 0      Fbsy :      0
Lli:             0      Loss_of_sig: 2
Proc_rqrd:      0      Protocol_err: 0
Timed_out:      0      Invalid_word: 0
Rx_flushed:     0      Invalid_crc: 0
Tx_unavail:     0      Delim_err: 0
Free_buffer:    0      Address_err: 0
Overrun:        0      Lr_in: 0
Suspended:     0      Lr_out: 0
Parity_err:     0      Ols_in: 0
2_parity_err:  0      Ols_out: 0
CMI_bus_err:    0
Port part of other ADs: No

```

10. Enter the **switchShow** command to verify the EX\_Port (or VEX\_Port), edge fabric ID, and name of the edge fabric switch (containing the E\_Port or VE\_Port) are correct.
11. Enter the **fcrFabricShow** command to view any edge fabric switch names and ensure links are working as expected.

#### NOTE

The **fcrFabricShow** command displays the static IPv6 addresses for each FC router and each edge fabric switch connected to the EX\_Ports.

```

switch:admin> fcrfabricshow
FCR WWN: 10:00:00:05:1e:13:59:00, Dom ID: 2, Info: 10.32.156.52 1080::8:800:200C:1234/64,"Spirit-2"
"fcr_5300"
EX_Port FID Neighbor Switch Info (WWN, enet IP, name)
-----
 7 10 10:00:00:05:1e:34:11:e5 10.32.156.33 "5300" 1080::8:8FF:FE0C:417A/64
 4 116 10:00:00:05:1e:37:00:44 10.32.156.34 "5300"
FCR WWN: 10:00:00:05:1e:12:e0:00, Dom ID: 100, Info:10.32.156.50 1080::8:60F:FE0C:456A/64
"fcr_5300"
EX_Port FID Neighbor Switch Info (WWN, enet IP, name)
-----
 4 95 10:00:00:05:1e:37:00:45 10.32.156.31 "5300"
FCR WWN: 10:00:00:05:1e:12:e0:00, Dom ID: 100, Info: 10.32.156.50, "fcr_Brocade 5300"
EX_Port FID Neighbor Switch Info (WWN, enet IP, name)
-----
 4 95 10:00:00:05:1e:37:00:45 10.32.156.31 "Brocade 5300"
 5 95 10:00:00:05:1e:37:00:45 10.32.156.31 "Brocade 5300"
 6 95 10:00:00:05:1e:37:00:45 10.32.156.31 "Brocade 5300"

```

12. Enter the **iflshow** command to display the FC router details and ensure the fabric is functioning correctly.

```

switch:FID128:root> iflshow
      E-Port      EX-Port      FCR-WWN      FCR-FID      FCR-Name      Speed      BW

```

```
-----
1 : 350 --> 12      10:00:08:00:88:04:93:94      39      fcr_sw      4G      8G      TRUNK
```

## Configuring EX\_Ports on an ICL

The following restrictions apply when configuring EX\_Ports on an ICL:

- Both the active and standby CP must be running Fabric OS 7.2.0 or later in the case of DCX 8510 Backbone.
- EX\_Port on ICL is supported in DCX 8510 Backbones and X6 Directors when all the port blades in the chassis belong to one of these blade types: FC16-32, FC16-48, FC16-64, FC32-48.

### NOTE

Device discovery will not occur properly with ICL EX\_Port connected edge fabrics if the FC router has unsupported blades that are not mentioned in the previous restriction.

- Switches must have Virtual Fabrics enabled.
- EX\_Ports on ICLs are allowed only on the base switch. F\_Ports are not supported in the base switch.
- You must be in Brocade native mode.
- You cannot configure a VEX\_Port on an ICL .
- The ICLs must be in a symmetric topology. For more information on topologies, refer to the chapter on Inter-Chassis Links (ICLs).
- Bladeless configuration (where the chassis has core blades but no application blades) is not supported.

To configure EX\_Ports on an ICL, perform the following steps:

1. Configure an 8-bit zero-based Dynamic Area mode or a 10-bit Dynamic Area mode on the FC router to bring up ICL EX\_Ports.

```
Configure...
Enable a 256 Area Limit
(0 = No,
1 = Zero Based Area Assignment,
2 = Port Based Area Assignment): (0..2) [0]
```

The following options are available:

- **0:** 10-bit Dynamic Area Mode. ICL EX\_Ports, F\_Ports, and regular EX\_Ports have 8-bit areas.
  - **1:** 8-bit Dynamic Area Mode. ICL\_EX ports have 8-bit areas.
  - **2:** Not permitted if ICL ports are present in the logical switch.
2. On the FC router, disable all QSFP ports by issuing the **portDisable** command.

```
switch:admin> portdisable 6/20-23
```

You can verify that all ports have been disabled by issuing the **portShow** command for the ports.

3. Configure EX\_Ports on the ICL by issuing the **portCfgEXPort** command. If you configure EX\_Port on one of the QSFP ports, the configuration is automatically propagated to the other 3 QSFP ports.

The following example configures EX\_Port on one of the QSFP ports.

```
switch:admin> portcfgexport 6/20 -a 1 -f 45
2013/04/25-21:21:54, [FCR-1071], 29805, SLOT 4 | FID 2, INFO, Pluto, Port 6/20 is changed from non
FCR port to FCR port.
2013/04/25-21:21:54, [FCR-1071], 29806, SLOT 4 | FID 2, INFO, Pluto, Port 6/21 is changed from non
FCR port to FCR port.
2013/04/25-21:21:55, [FCR-1071], 29807, SLOT 4 | FID 2, INFO, Pluto, Port 6/22 is changed from non
FCR port to FCR port.
```

```
2013/04/25-21:21:55, [FCR-1071], 29808, SLOT 4 | FID 2, INFO, Pluto, Port 6/23 is changed from non FCR port to FCR port.
```

- (Optional) Configure FC router port cost if you want to change the default values. For information about using FC router port cost operations, refer to [FC router port cost configuration](#) on page 511.
- Enter the **portEnable** command to enable the QSFP ports that you disabled in step 1.

```
switch:admin> portenable 6/20-23
```

- Enter either the **portCfgEXPort** or **portShow** command to verify that each port is configured correctly.

```
switch:admin> portcfgexport 6/20
Port 6/20 info
Admin:          enabled
State:         OK
Pid format:    Not Applicable
Operate mode:  Brocade Native
Edge Fabric ID: 50
Preferred Domain ID: 160
Front WWN:    50:00:51:e7:54:c0:0e:32
Fabric Parameters: Auto Negotiate
R_A_TOV:      Not Applicable
E_D_TOV:      Not Applicable
Authentication Type: None
DH Group: N/A
Hash Algorithm: N/A
Edge fabric's primary wwn: N/A
Edge fabric's version stamp: N/A
```

- Enter the **switchShow** command to verify the EX\_Port and edge fabric ID are correct.
- Enter the **fcrEdgeShow** command to display the FIDs of all configured EX\_Ports.

```
switch:admin> fcredgeshow
FID EX-port E-port Neighbor Switch (PWWN, SWWN )
-----
50 3/12 1180 50:00:51:e4:8f:8f:74:9c 10:00:00:05:1e:48:f8:00
50 3/13 1181 50:00:51:e4:8f:8f:74:9d 10:00:00:05:1e:48:f8:00
50 3/14 1182 50:00:51:e4:8f:8f:74:9e 10:00:00:05:1e:48:f8:00
50 3/15 1183 50:00:51:e4:8f:8f:74:9f 10:00:00:05:1e:48:f8:00
```

- Enter the **fcrIclPathBwMonitor** command to monitor and report path bandwidth imbalances for each edge fabric.

The following example enables the monitoring and reporting of bandwidth balances and imbalances, and displays the ICL path bandwidth state for each fabric:

```
switch:admin> fcrIclPathBwMonitor --show
ICL Path Bandwidth state :Disabled
switch:admin> fcrIclPathBwMonitor --enable
ICL bandwidth balance functionality is enabled
Pluto:FID2:root> fcrIclPathBwMonitor --show
ICL Path Bandwidth state :Enabled
FABRIC      SLOT-3 BW      SLOT-6 BW      STATE
-----
48          128          128          BALANCED
126         64           128          UNBALANCED
```

## FC router port cost configuration

FC routers optimize the usage of the router port links by directing traffic to the link with the smallest router port cost.

The FC router port cost is similar to the link cost setting available on E\_Ports, which allows you to customize traffic flow. The router port link cost values are either 0, 1,000, or 10,000. The router module chooses the router port path based on the lowest cost for each FID

connection. If multiple paths exist where one path costs less than the others, then the lowest cost path is used. If exchange-based routing has not been disabled and multiple paths exist with the same lowest cost, there will be load sharing over these paths.

Every IFL has a default cost. The default router port cost values are as follows:

- 1,000 for a legacy (v5.1 or XPath FCR) IFL
- 1,000 for an EX\_Port IFL
- 10,000 for a VEX\_Port IFL

The FC router port cost settings are 0, 1,000, or 10,000. If the cost is set to 0, the default cost will be used for that IFL. The FC router port cost is persistent and is saved in the existing port configuration file.

FC router port cost is passed to other routers in the same backbone. Link costs from the front domain to the translate (xlate) domain remain at 10,000. You can use the **IsDbShow** command from the edge fabric to display these link costs.

The FC router port cost is set automatically. You can modify the cost for a port if you want to change the default value.

## Port cost considerations

The router port cost has the following considerations:

- Router port sets are defined as follows:
  - 0-7 and FCIP Tunnel 16-23
  - 8-15 and FCIP Tunnel 24-31
- The router port cost does not help distinguish one IFL (or EX\_ and VEX\_Port link) from another, if all the IFLs are connected to the same port set. Therefore, if you connect IFL1 and IFL2 to the same edge fabric in port set 0-7 and then configure them to different router port costs, traffic is still balanced across all the IFLs in the same port set.
- Use proper SAN design guidelines to connect the IFLs to different port sets for effective router port cost use. For example, if both a low-speed IFL and a high-speed IFL are going to the same edge fabric, connect the lower router cost IFL to a separate port group (for example, ports 0-7) than the higher router cost IFL (for example, ports 8-15). For VEX\_Ports, you would use ports in the range of 16-23 or 24-31.

You can connect multiple EX\_Ports or VEX\_Ports to the same edge fabric. The EX\_Ports can all be on the same FC router, or they can be on multiple routers. Multiple EX\_Ports create multiple paths for frame routing. Multiple paths can be used in two different, but compatible, ways:

- Failing over from one path to another.
- Using multiple paths in parallel to increase effective data transmission rates.

EX\_Ports and VEX\_Ports, when connected, are assigned different router port costs and traffic will flow only through the EX\_Ports. Routing failover is automatic, but it can result in frames arriving out of order when frames take different routes. The FC router can force in-order delivery, although frame delivery is delayed immediately after the path failover.

Source EX\_Ports can balance loads across multiple destination EX\_Ports attached to the same edge fabric using exchange IDs from the routed frames as keys to distribute the traffic.

## Setting router port cost for an EX\_Port

The router port cost value for an EX\_Port is set automatically when the EX\_Port is created. You can modify the cost for that port to force a path to have a higher or lower cost.

You can configure the EX\_Port or VEX\_Port with values of either 1,000 or 10,000. For example, if you want to differentiate between two EX\_Port links with different speeds, you can assign 1,000 to one link and 10,000 to the other link.

1. Enter the **portDisable** command to disable any port on which you want to set the router port cost.

```
switch:admin> portdisable 7/10
```

2. Enable EX\_Port or VEX\_Port mode with the **portCfgEXPort** or **portCfgVEXPort** command.

```
switch:admin> portcfgexport 7/10 -a 1
```

3. Enter the **fcrRouterPortCost** command to display the router port cost for each EX\_Port.

```
switch:admin> fcrrouterportcost
Port          Cost
-----
7/3           1000
7/4           1000
7/9           1000
7/10          1000
7/13          1000
10/0          1000
```

You can also use the **fcrRouteShow** command to display the router port cost.

To display the router port cost for a single EX\_Port, enter the **fcrRouterPortCost** command with a port and slot number.

```
switch:admin> fcrrouterportcost 7/10
Port          Cost
-----
7/10          1000
```

4. Enter the appropriate form of the **fcrRouterPortCost** command based on the task you want to perform:
  - To set the router port cost for a single EX\_Port, enter the command with a port and slot number and a specific cost:

```
switch:admin> fcrrouterportcost 7/10 10000
```

- To set the cost of the EX\_Port back to the default, enter a cost value of 0:

```
switch:admin> fcrrouterportcost 7/10 0
```

5. Enter the **portEnable** command to enable the ports that you disabled in step 1.

```
switch:admin> portenable 7/10
```

## Shortest IFL cost configuration

You can direct traffic flow to take the shortest path between host and target when multiple FC routers in the backbone are connected to an edge fabric. Shortest inter-fabric link mode is disabled by default. When you enable shortest IFL mode, an FC router can choose a lowest cost ISL path in the backbone fabric. This feature is useful when an FC router has multiple connections to the source edge fabric, and the backbone fabric has multiple FC routers connected through FCIP links (VE\_Ports) and FC links (E\_Ports). The selection of a low cost path depends on individual ISL link cost settings in the backbone fabric. Traffic originating from a domain in an edge fabric can choose any equal cost path in order to reach the destination edge fabric. This traffic can be transmitted through high cost paths, such as FCIP links, within the backbone fabric even though low cost paths, such as FC links, are present.

When the shortest IFL mode is enabled, each FC router calculates the shortest path for each of its locally-connected source edge fabrics to a remote destination edge fabric that is connected to another FC router in the same backbone fabric. The FC router performs this calculation by identifying all paths in the backbone fabric that can connect the source edge fabric to the destination edge fabric. The cumulative ISL link cost for each path is then calculated:

- For any path for which the cumulative ISL link cost of the path is greater than or equal to 10,000, the FC router sets the link cost from the front domain to translate the domain as 10,001.

- For any path for which the cumulative ISL link cost of the path is less than 10,000, the link cost from front domain to translate domain will remain at 10,000, which is the shortest IFL path.

**NOTE**

The shortest IFL solution is applicable only when the edge fabric has multiple FC router connections and the backbone fabric has at least one available low cost path. Shortest IFL mode should be enabled on all FC routers in the backbone fabric for this feature to work correctly.

Figure 81 shows a shortest IFL solution. In order for Host 12 in Domain 1 in Edge fabric 1 to reach Target 2 in Domain 3 in Edge fabric 3, traffic can choose one of two paths in the backbone fabric:

- Path 1: Edge fabric 1-FCR1 - FCR2 -FCR3 -Edge fabric 3.
- Path 2: Edge fabric 1-FCR4 - FCR3 -Edge fabric 3.

The second path is identified as the low cost path by setting the ISL link cost to 5,000. The first path is considered the high cost path where the cumulative ISL cost is 10,000.

**NOTE**

Link cost should be set in the direction of traffic flow from the source edge fabric to the destination edge fabric.

**FIGURE 81** Shortest IFL solution

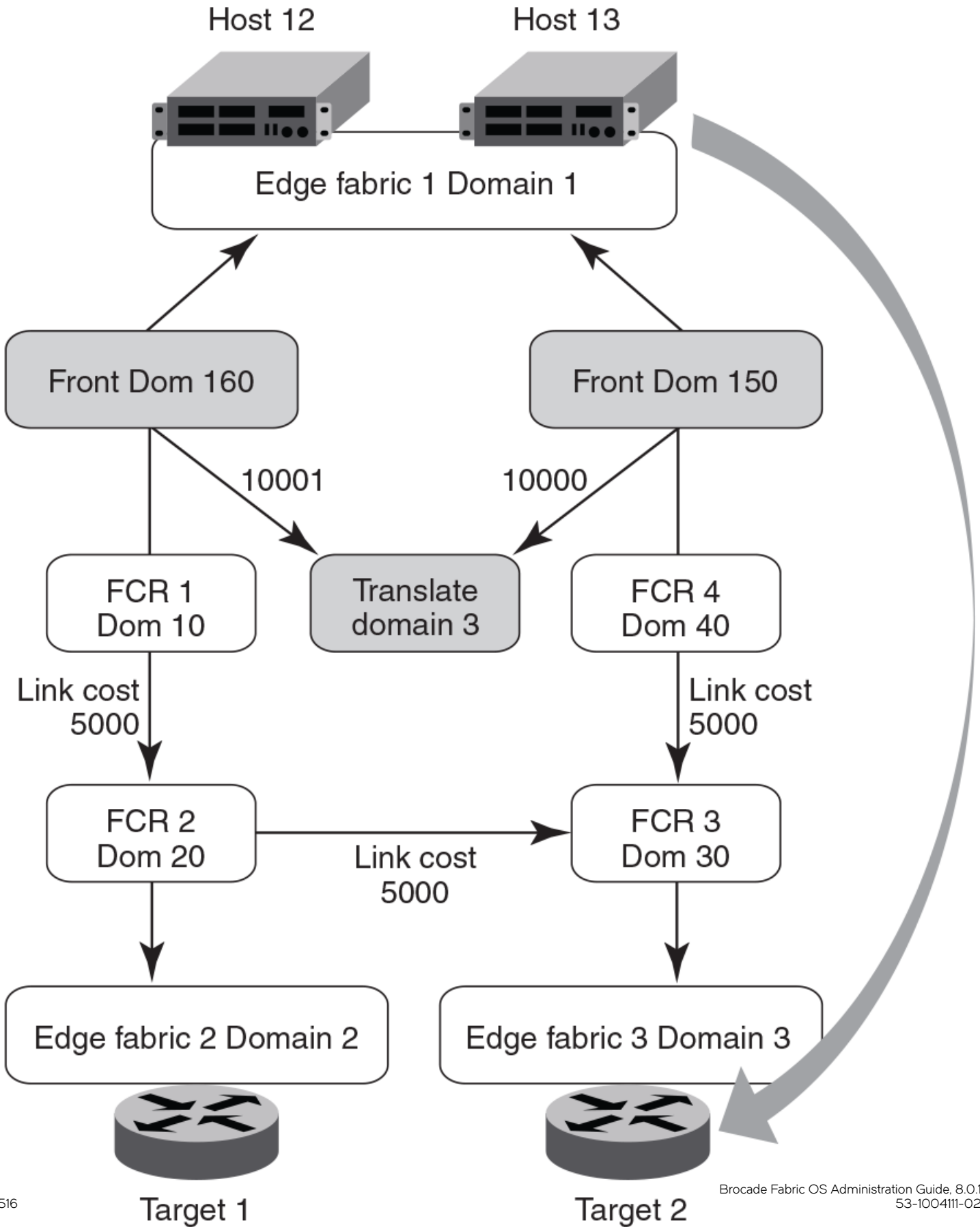



## Configuring shortest IFL cost

1. Enter the **fcrFabricShow** command to view the FC routers on the backbone fabric.

```
switch:admin>fcrfabricshow
FC Router WWN: 10:00:00:05:1e:58:bd:69, Dom ID: 10,
Info: 10.17.33.59, "DID_10"
EX_Port      FID      Neighbor Switch Info (enet IP, WWN, name)
-----
      34      1      10.17.33.68      10:00:00:05:1e:61:28:22      "DID_4_1"
switch:admin>fcrfabricshow
FC Router WWN: 10:00:00:05:1e:58:be:69, Dom ID: 20,
Info: 10.17.33.60, "DID_20"
EX_Port      FID      Neighbor Switch Info (enet IP, WWN, name)
-----
      2      2      10.17.33.88      10:00:00:05:33:00:90:48      "DID_1_2"
switch:admin>fcrfabricshow
FC Router WWN: 10:00:00:05:1e:58:be:68, Dom ID: 30,
Info: 10.17.33.61, "DID_30"
EX_Port      FID      Neighbor Switch Info (enet IP, WWN, name)
-----
      31      3      10.17.33.153      10:00:00:05:33:7e:e8:7c      "DID_3_3"
switch:admin>fcrfabricshow
FC Router WWN: 10:00:00:05:1e:58:be:67, Dom ID: 40,
Info: 10.17.33.62, "DID_40"
EX_Port      FID      Neighbor Switch Info (enet IP, WWN, name)
-----
      34      1      10.17.33.68      10:00:00:05:1e:61:28:22      "DID_4_1"
```

2. Enter the **islshow** command to identify the connections between the FC routers and the destination edge fabric.

```
switch:admin>islshow
1: 10->1010:00:00:05:1e:58:be:69 20 DID_20 sp: 8.000G bw: 8.000G TRUNK QOS
```

3. Identify all paths in the backbone fabric through which traffic can flow from the source edge fabric to the destination edge fabric by examining the output generated in step 1 and step 2.

The following example step shows how to identify the number of paths from the source edge fabric 1 to the destination edge fabric 2 in the backbone fabric based on the configuration shown in step 1 and step 2:

- The path from FC router Domain ID 10 to FC router Domain ID 20.
- The path from FC router Domain 20: This FC router has no local connection to source edge fabric 1, so cannot be considered for path identification.
- The path from FC router Domain 30: This FC router has no local connection to source edge fabric 1, so cannot be considered for path identification.
- The path from FC router Domain ID 40 to FC router Domain ID 30 to FC router Domain ID 20.

Therefore, there are two available paths in the backbone fabric through which traffic can flow from the source edge fabric 1 to the destination edge fabric 2.

4. Enter the **linkcost** command to obtain the cumulative ISL cost for each path identified by adding all individual link costs, and select one single path to be the only low cost path.
  - The following example shows the cumulative ISL cost for the first path identified in step 3: from FC router ID Domain 10 to FC router ID Domain 20.

```
switch:admin>linkcost 10
Interface10 (E_PORT) Cost 500
```

The cumulative link cost for this path is 500. This path is now known as path 1.

- The following example shows the cumulative ISL cost for the second path identified in step 3: first from FC router ID Domain 40 to FC router ID Domain 30, and then from FC router Domain ID 30 to FC router ID Domain 20.

```
switch:admin>linkcost 10
Interface10 (E_PORT) Cost 500
switch:admin>linkcost 10
Interface10 (E_PORT) Cost 500
```

The cumulative link cost for this path is 1000. This path is now known as path 2.

Path 1 is selected as the low cost path.

- Enter the **linkcost** command to set low cost values, ensuring that the cumulative ISL cost for the selected path is lower than that of all other paths. A low cost path should have a cumulative ISL cost of less than 10,000.

- In the following example, the ISL link cost of path 2 from FC router ID Domain 40 to FC router Domain ID 30 is modified.

```
switch:admin>linkcost 10 5000
Interface10 (E_PORT) Cost 5000
```

- In the following example, the ISL link cost of path 2 from FC router Domain 30 to FC router Domain 20 is modified.

```
switch:admin>linkcost 10 5000
Interface10 (E_PORT) Cost 5000
```

The modified cumulative link cost for path 2 is 10,000.

- Enter the **fcrConfigure --enable -shortestifl** command to enable the shortest IFL mode in all the FC routers in the backbone fabric.

```
switch:admin> fcrconfigure --enable -shortestifl
Shortest IFL path is enabled
```

- Enter the **fcrConfigure -show** command to verify that the shortest IFL mode is enabled in all the FC routers in the backbone fabric.

```
switch:admin> fcrconfigure --show
Backbone fabric ID: 128
Shortest IFL feature is enabled
```

- Verify that the link cost of both the front domain and translate domain in the source edge fabric have been modified using the **lsDbShow** command.

```
linkCnt = 2, flags = 0x0
LinkId = 160, out port = 160 rem port = 241, cost = 10001, costCnt = 0, type = 1
LinkId = 161, out port = 161, rem port = 242, cost = 10000, costCnt = 0, type = 1
```

## EX\_Port frame trunking configuration

EX\_Port frame trunking provides the best utilization and balance of frames transmitted on each link between the FC router and the edge fabric. You should trunk all ports connected to the same edge fabrics.

You configure EX\_Ports to use frame-based trunking just as you do regular E\_Ports. The restrictions for EX\_Port frame trunking are the same as for E\_Ports. All the ports must be adjacent to each other using the clearly marked groups on the front of the product.

The FC router front domain has a higher node WWN, derived from the FC router, than that of the edge fabric. Therefore, the FC router front domain initiates the trunking protocol on the EX\_Port.

After initiation, the first port from the trunk group that comes online is designated as the master port. The other ports that come online on the trunk group are considered the slave ports. Adding or removing a slave port does not cause frame drop. However, removing a slave port causes the loss of frames in transit.

If router port cost is used with EX\_Port trunking, the master port and slave ports share the router port cost of the master port.

For information about setting up E\_Port trunking on an edge fabric, refer to [Managing Trunking Connections](#) on page 467.

## LSAN zone configuration

An LSAN consists of zones in two or more edge or backbone fabrics that contain the same devices. LSANs provide selective device connectivity between fabrics without forcing you to merge those fabrics. FC routers provide multiple mechanisms to manage inter-fabric device connectivity through extensions to existing switch management interfaces. You can define and manage LSANs using Brocade Advanced Zoning.

### NOTE

For performance reasons, Brocade recommends that you do not configure LSANs for device sharing between Fabric OS fabrics until after you activate the Integrated Routing license.

## Zone definition and naming

Zones are defined locally on a switch or backbone. Names and memberships, with the exception of hosts and targets exported from one fabric to another, do not need to be coordinated with other fabrics. For example, in [Figure 77](#) on page 495, when the zones for Edge SAN 1 are defined, you do not need to consider the zones in Edge SAN 2, and vice versa.

Zones that contain hosts and targets that are shared between the two fabrics must be explicitly coordinated. To share devices between any two fabrics, you must create an LSAN zone in both fabrics containing the port WWNs of the devices to be shared. Although an LSAN is managed using the same tools as any other zone on the edge fabric, two behaviors distinguish an LSAN from a conventional zone:

- A required naming convention. The name of an LSAN begins with the prefix "LSAN\_". The LSAN name is not case-sensitive; for example, "lsan\_" is equivalent to "LSAN\_", "Lsan\_", and so on.
- Members must be identified by their port WWN because port IDs are not necessarily unique across fabrics. The names of the zones need not be explicitly the same, and membership lists of the zones need not be in the same order.

### NOTE

The "LSAN\_" prefix must appear at the beginning of the zone name. LSAN zones may not be combined with QoS zones. Refer to QoS zones for more information about the naming convention for QoS zones.

To enable device sharing across multiple fabrics, you must create LSAN zones on the edge fabrics (and optionally on the backbone fabric as well), using normal zoning operations to create zones with names that begin with the special prefix "LSAN\_"; and adding host and target port WWNs from both local and remote fabrics to each local zone as desired. Zones on the backbone and on multiple edge fabrics that share a common set of devices will be recognized as constituting a single multi-fabric LSAN zone, and the devices that they have in common will be able to communicate with each other across fabric boundaries.

## LSAN zones and fabric-to-fabric communications

Zoning is enforced by all involved fabrics and any communication from one fabric to another must be allowed by the zoning setup on both fabrics. If the LSANs are under separate administrative control, then separate administrators maintain access control.

## Controlling device communication with the LSAN

The following procedure illustrates how LSANs control which devices can communicate with each other. The procedure shows the creation of two LSANs (called "lsan\_zone\_fabric75" and "lsan\_zone\_fabric2"), which involve the following devices and connections:

- Switch1 and the host in fabric75
  - Switch2, Target A, and Target B in fabric2
  - Switch1 is connected to the FC router using an EX\_Port or VEX\_Port
  - Switch2 is connected to the FC router using another EX\_Port or VEX\_Port
  - Host has WWN 10:00:00:00:c9:2b:c9:0c (connected to switch1)
  - Target A has WWN 50:05:07:61:00:5b:62:ed (connected to switch2)
  - Target B has WWN 50:05:07:61:00:49:20:b4 (connected to switch2)
1. Log in as admin and connect to switch1.
  2. Enter the **nsShow** command to list the WWN of the host (10:00:00:00:c9:2b:c9:0c).

### NOTE

The **nsShow** output displays the LSAN zone status of a device, the port WWN, and the node WWN; the port WWN must be used for LSANs.

```
switch:admin> nsshow
{
  Type Pid      COS      PortName          NodeName          TTL(sec)
  N   060f00;   2,3;    10:00:00:00:c9:2b:c9:0c;  20:00:00:00:c9:2b:c9:0c; na
  FC4s: FCP
  NodeSymb: [35] "Emulex LP9002 FV3.91A3 DV5-5.20A6 "
  Fabric Port Name: 20:0f:00:05:1e:37:00:44
  Permanent Port Name: 10:00:00:00:c9:2b:c9:0c
  LSAN: Yes
  The Local Name Server has 1 entry }
```

3. Enter the **zoneCreate** command to create the LSAN "lsan\_zone\_fabric75", which includes the host.

```
switch:admin> zonecreate "lsan_zone_fabric75", "10:00:00:00:c9:2b:c9:0c"
```

4. Enter the **zoneAdd** command to add Target A to the LSAN.

```
FID75Domain5:admin> zoneadd "lsan_zone_fabric75", "50:05:07:61:00:5b:62:ed"
```

5. Enter the **cfgAdd** or **cfgCreate** and **cfgEnable** commands to add and enable the LSAN configuration.

```
switch:admin> cfgadd "zone_cfg", "lsan_zone_fabric75"
switch:admin> cfgenable "zone_cfg"
You are about to enable a new zoning configuration.
This action will replace the old zoning configuration with the
current configuration selected.
Do you want to enable 'zone_cfg' configuration (yes, y, no, n): [no] y
zone config "zone_cfg" is in effect
Updating flash ...
```

6. Log in as admin to fabric2.
7. Enter the **nsShow** command to list Target A (50:05:07:61:00:5b:62:ed) and Target B (50:05:07:61:00:49:20:b4).

```
switch:admin> nsshow
{
  Type Pid      COS      PortName          NodeName          TTL(sec)
  NL  0508e8;   3;      50:05:07:61:00:5b:62:ed;  50:05:07:61:00:1b:62:ed; na
  FC4s: FCP [IBM   DNEF-309170   F90F]
  Fabric Port Name: 20:08:00:05:1e:34:11:e5
  Permanent Port Name: 50:05:07:61:00:5b:62:ed
```

```

NL 0508ef; 3; 50:05:07:61:00:49:20:b4; 50:05:07:61:00:09:20:b4; na
FC4s: FCP [IBM DNEF-309170 F90F]
Fabric Port Name: 20:08:00:05:1e:34:11:e5
Permanent Port Name: 50:05:07:61:00:49:20:b4
LSAN: Yes
The Local Name Server has 2 entries }

```

- Enter the **zoneCreate** command to create the LSAN "lsan\_zone\_fabric2", which includes the host (10:00:00:00:c9:2b:6a:2c), Target A, and Target B.

```

switch:admin> zonecreate "lsan_zone_fabric2", "10:00:00:00:c9:2b:c9:0c;50:05:07:61:00:5b:62:ed;
50:05:07:61:00:49:20:b4"

```

- Enter the **cfgShow** command to verify that the zones are correct.

```

switch:admin> cfgshow
Defined configuration:
zone: lsan_zone_fabric2
      10:00:00:00:c9:2b:c9:0c; 50:05:07:61:00:5b:62:ed;
      50:05:07:61:00:49:20:b4
Effective configuration:
no configuration in effect

```

- Enter the **cfgAdd** and **cfgEnable** commands to create and enable the LSAN configuration.

```

switch:admin> cfgadd "zone_cfg", "lsan_zone_fabric2"
switch:admin> cfgenable "zone_cfg"
You are about to enable a new zoning configuration.
This action will replace the old zoning configuration with the
current configuration selected.
Do you want to enable 'zone_cfg' configuration (yes, y, no, n): [no] y
zone config "zone_cfg" is in effect
Updating flash ...

```

- Log in as admin and connect to the FC router.

- Enter the following commands to display information about the LSANs:

- lsanZoneShow -d** displays the fabric ID of the LSAN devices and whether the device physically exists in the fabric or is imported from another fabric.

```

switch:admin> lsanzoneshow -d
Fabric ID: 2 Zone Name: lsan_zone_fabric2
10:00:00:00:c9:2b:c9:0c Imported from FID 75
50:05:07:61:00:5b:62:ed EXIST in FID 2
50:05:07:61:00:49:20:b4 EXIST in FID 2
Fabric ID: 75 Zone Name: lsan_zone_fabric75
10:00:00:00:c9:2b:c9:0c EXIST in FID 75
50:05:07:61:00:5b:62:ed Imported from FID 2

```

- lsanZoneShow -o|-sort** displays the WWNs in sorted order. The **lsanZoneShow -o** command applies to peer zone rules and displays the WWNs in sorted order if LSAN zones are peer zones.
- fcrPhyDevShow** shows the physical devices in the LSAN.

```

switch:admin> fcrphydevshow
Device          WWN          Physical
Exists          PID
in Fabric
-----
75 10:00:00:00:c9:2b:c9:0c c70000
2 50:05:07:61:00:49:20:b4 0100ef
2 50:05:07:61:00:5b:62:ed 0100e8
Total devices displayed: 3

```

- **fcrProxyDevShow** shows the proxy devices in the LSAN.

```
switch:admin> fcrproxydevshow
```

Proxy Created in Fabric	WWN	Proxy PID	Device Exists in Fabric	Physical PID	State
75	50:05:07:61:00:5b:62:ed	01f001	2	0100e8	Imported
2	10:00:00:00:c9:2b:c9:0c	02f000	75	c70000	Imported

Total devices displayed: 2

On the FC router, the host and Target A are imported, because both are defined by "lsan\_zone\_fabric2" and "lsan\_zone\_fabric75". However, Target B is defined by "lsan\_zone\_fabric2" and is not imported because "lsan\_zone\_fabric75" does not allow it.

When a PLOGI, PDISC, or ADISC arrives at the FC router, the SID and DID of the frame are checked. If they are LSAN-zoned at both SID and DID edge fabrics, the frame is forwarded to the DID. If they are not zoned, only the PLOGI is dropped and the remaining frames zoning enforcement takes place in the edge fabrics.

## Configuring interconnectivity between backbone and edge fabrics

If you want devices in backbone fabrics to communicate with devices in edge fabrics, set up the LSANs as described [Controlling device communication with the LSAN](#) on page 520. However, instead of configuring the LSAN in the second edge fabric, configure the LSAN in the backbone fabric.

## Setting the maximum LSAN count

You can set the maximum number of LSAN zones, or LSAN count, that can be configured on the edge fabrics. By default, the maximum LSAN count is set to 3,000. You can increase the maximum LSAN count to 5,000 without disabling the switch.

The maximum number of LSAN devices supported is 10,000 (this includes both physical and proxy devices). If you have 3,000 LSAN zones but have not exceeded the 10,000 device limit, you can increase the LSAN count to 5,000.

All FC routers in the same backbone fabric should have the same maximum LSAN count defined, to prevent the FC routers from running into indefinite state. Asymmetric LSAN configurations due to different maximum LSAN counts could lead to different devices being imported on different FC routers.

1. Enter the **fcrlsancount** command with no parameters to display the current LSAN limit.

```
switch:admin> fcrlsancount
LSAN Zone Limit 3000
```

2. Enter the **fcrlsancount** command and specify the new LSAN zone limit.

```
switch:admin> fcrlsancount 5000
LSAN Zone Limit 5000
```

For information on how to display the maximum allowed and currently used LSAN zones and devices, refer to [Resource monitoring](#) on page 538.

### NOTE

Because the maximum number of LSANs is configured for each switch, if there is a different maximum LSAN count on the switches throughout the metaSAN, then the device import and export will not be identical on the FC routers. You should enter the same maximum LSAN count for all the FC routers in the same backbone that support this feature. Verify the configured maximum limit against the LSANs configured using the **fcrResourceShow** command.

## HA and downgrade considerations for LSAN zones

Be aware of how LSAN zones impact high availability and firmware downgrades:

- The LSAN zone matrix is synchronized to the standby CP.
- On a dual CP switch, both CPs must have Fabric OS v5.3.0 or later.
- If the feature is enabled on the active CP, introducing a CP with an earlier version of Fabric OS as a standby will cause HA synchronization to fail.
- If the feature is enabled, before downgrading to an earlier Fabric OS version, you will be asked to go back to the default mode.
- This feature does not have any impact on current HA functionality. LSANs will be synchronized as usual after the limit is increased and new LSANs are created.
- In a Backbone-to-edge routing topology, if the "FCR state" in the switch is disabled and the switch is downgraded to pre-Fabric OS 8.0.1 and then subsequently the "FCR state" is enabled, you must re-enable the zone configuration in the backbone fabric if "lsanzoneshow -s" for the backbone fabric ID is not displayed.

## LSAN zone policies using LSAN tagging

You can create tags for LSAN zones to give them a special meaning.

LSAN zones are zones with names that start with the "lsan\_" prefix. You can specify a tag to append to this prefix that causes the LSAN zone to be treated differently.

You can specify two types of tags:

- Enforce tag - Specifies which LSANs are to be enforced in an FC router.
- Speed tag - Specifies which LSANs are to be imported or exported faster than other LSANs.

The LSAN tags are persistently saved and support **configupload** and **configdownload**.

### Enforce tag

Use the Enforce tag to achieve better scalability in the FC router by limiting the number of LSAN zones that are enforced in that FC router.

The Enforce tag reduces the resources used in an FC router by limiting the number of LSAN zones that will be enforced in that FC router. Use the Enforce tag to achieve better scalability in the FC router.

The Enforce tag is useful in the following scenarios:

- Multiple FC routers are connected to the same edge fabric.
- The backbone fabric contains multiple FC routers with multiple edge fabrics.

In these scenarios, often an FC router does not need to know about all edge fabrics and their respective LSAN zones. You can use the Enforce tag to indicate which LSAN zones are imported by which FC routers. Without the Enforce tag, all FC routers import all LSAN zones, even those that are not needed.

For example, the following figure shows a metaSAN with three FC routers in the backbone, and each FC router has one edge fabric connected to it. In this scenario, LSAN zones communicate between edge fabric 1 and edge fabric 2, and between edge fabric 2 and edge fabric 3. There is no communication between edge fabric 1 and edge fabric 3.

FIGURE 82 Example of setting up Enforce LSAN tag

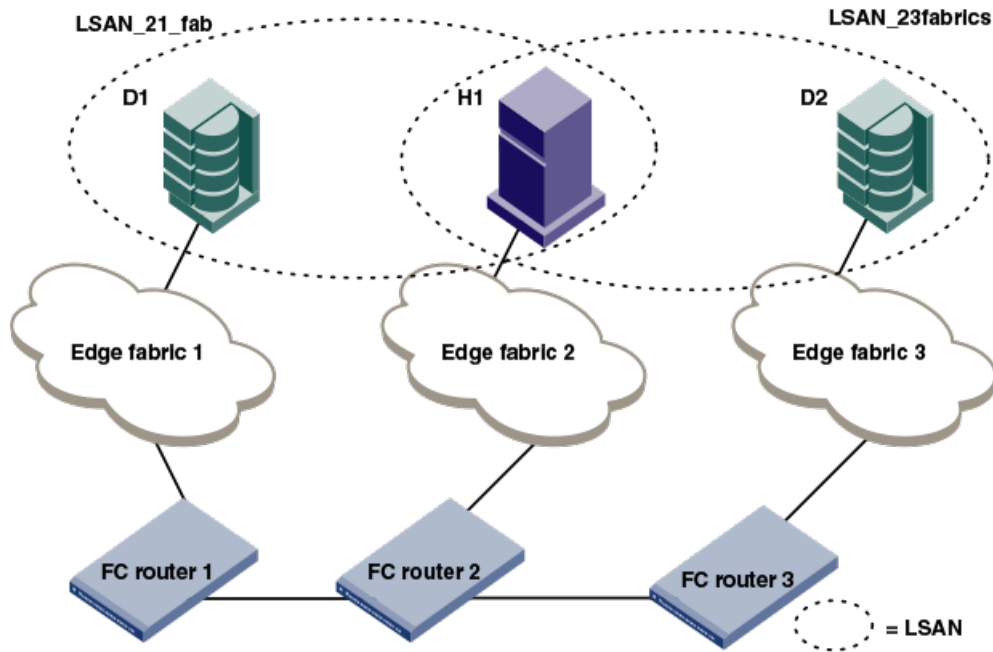

FC router 1 does not need to know about the LSAN between edge fabrics 2 and 3. Likewise, FC router 3 does not need to know about the LSAN between edge fabrics 1 and 2.

In this scenario, you could set up two Enforce tags, one for each LSAN. On FC router 2, both Enforce tags would be needed, since FC router 2 uses both LSANs. FC router 1 and FC router 3 each need only one tag, for their respective LSANs.

Setting up Enforce tags in this way keeps resources on FC router 1 and FC router 3 at a minimum. This is a simple example, but could become more complex as more FIDs are added to each FC router or as additional FC routers are added to the backbone.

### How the Enforce tag works

The FC router automatically accepts all zones with names that start with "lsan\_". You can specify an Enforce tag to indicate that a particular FC router should accept only zones that start with the prefix "lsan\_*tag*". For example, if you specify an Enforce tag of "abc", the FC router accepts only those LSAN zones that start with "lsan\_abc" and does not import or export any other LSAN zones.

The Enforce tag can be up to eight characters long and can contain only letters and numbers.

The Enforce tag is not case-sensitive; for example, the tag "abc" is equivalent to "ABC" and "Abc".

If you specify "abc", "xyz", and "fab1" as Enforce tags, then the FC router accepts only those LSAN zones with names that start with any of the following:

- lsan\_abc
- lsan\_xyz
- lsan\_fab1

In this example, the following LSAN zones would all be accepted:

- lsan\_abc
- Lsan\_xyz123456



- LSAN\_FAB1\_abc

You can specify up to eight Enforce tags on an FC router.

For example, in the figure above, you could configure the following Enforce tags on the FC routers:

- For FC router 1, configure one Enforce tag, "21".  
FC router 1 would accept all LSAN zones starting with "LSAN\_21", and so would accept LSAN\_21\_fab, but not LSAN\_23fabrics.
- For FC router 2, configure two Enforce tags, "21" and "23".  
FC router 2 would accept all LSAN zones starting with "LSAN\_21" and "LSAN\_23", and so would accept both "LSAN\_21\_fab" and "LSAN\_23fabrics".  
Alternatively, you could configure only one Enforce tag, "2", which would handle both of the LSANs.
- For FC router 3, configure one Enforce tag, "23".  
FC router 3 would accept all LSAN zones starting with "LSAN\_23", and so would accept LSAN\_23fabrics, but not LSAN\_21\_fab.

## Speed tag

The Speed tag allows you to speed up the discovery process by importing devices into the remote edge fabrics when the devices come online, regardless of the state of the host.

During target discovery, the FC router process of presenting proxy devices and setting up paths to the proxy devices may cause some sensitive hosts to time out or fail. Using the Speed tag helps sensitive hosts to quickly discover the devices without timing out.

The Speed tag is used primarily when there are boot over SAN devices across an LSAN.

You set the Speed tag on the FC router, and then configure the LSANs in the target edge fabrics with the tag.

The FC router automatically accepts all zones with names that start with "lsan\_". You can specify a Speed tag to indicate that devices in LSAN zones that start with the prefix "lsan\_*tag*", should be imported into the remote edge fabrics when the devices come online.

For example, in the following figure, assume that the host, H1, needs fast access to target devices D1 and D2. You could set up the Speed tag as follows:

1. In FC router 1 and FC router 2, configure the Speed tag as "super".
2. In Edge fabric 2, configure two LSANs:  
lsan\_f2\_f1 (H1, D1)  
lsan\_f2\_f3 (H1, D2)  
The LSAN in the host fabric does not need the tag.
3. In Edge fabric 1, configure the following LSAN:  
lsan\_super\_f1\_f2 (H1, D1)
4. In Edge fabric 3, configure the following LSAN:  
lsan\_super\_f3\_f2 (H1, D2)
5. Choose either the host or target to trigger the fast import process.

The "super" tag is needed only in the LSANs of the target fabrics.

The target proxies D1 and D2 are always present in the host fabric (Edge fabric 2), even if the host is brought down. A target proxy is removed from the host fabric when the target device is offline.

FIGURE 83 Example of setting up Speed LSAN tag

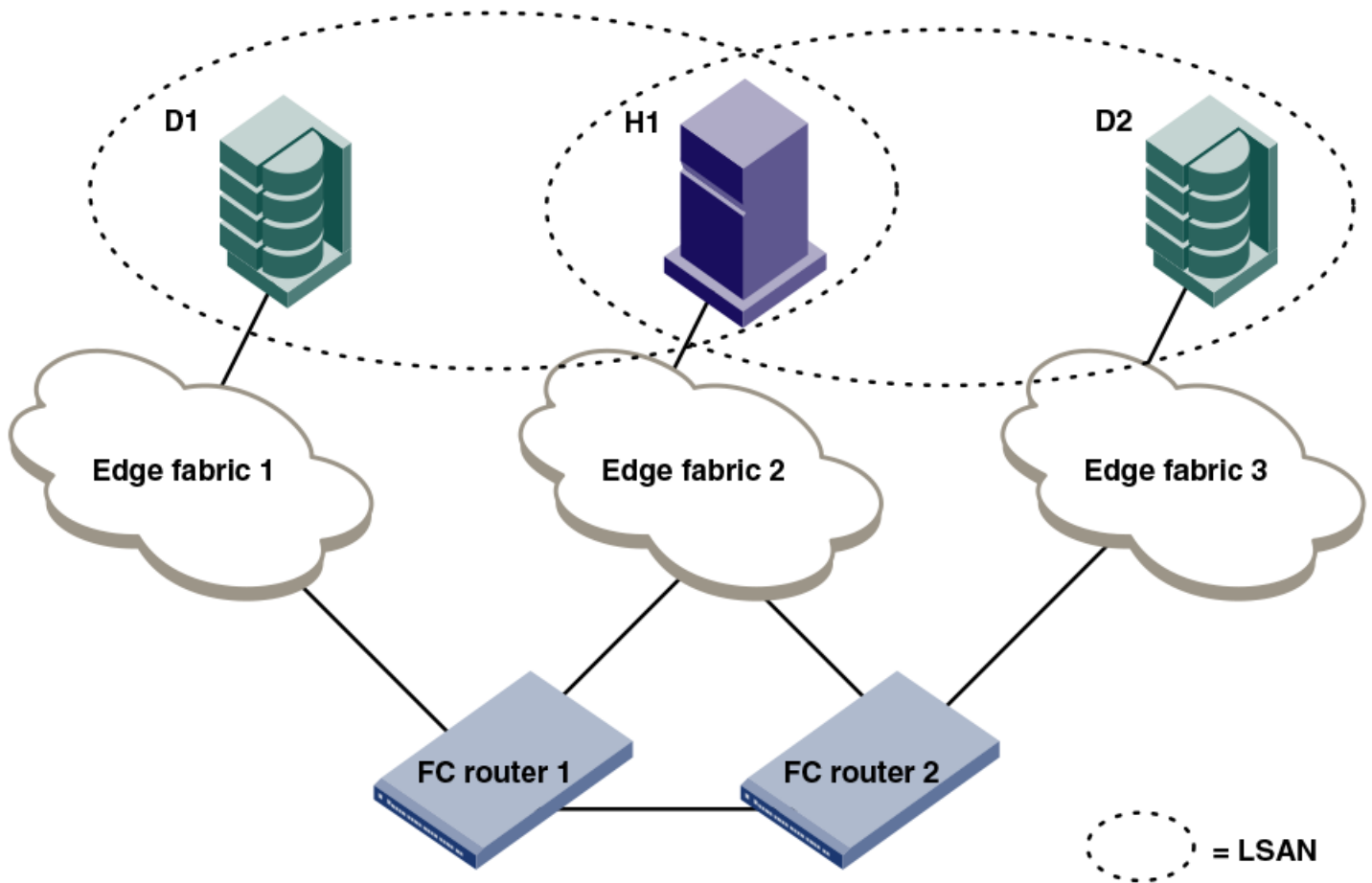

### Rules for LSAN tagging

Note the following rules for configuring LSAN tags:

- You configure the tags on the FC router, and not on the edge switches. If Virtual Fabrics is enabled, you configure the tags on the base switch on which the EX\_Ports and VEX\_Ports are located. You then must ensure that the LSAN zones in the edge fabrics incorporate the tags correctly.
- The LSAN tags are configured per FC router, not per fabric. If the backbone fabric has multiple FC routers, it is recommended that you configure the LSAN tags on all of the FC routers.
- The FC router must be disabled before you configure the Enforce tag. Configuring the Speed tag does not require that the FC router be disabled. However, after configuring the Speed tag, you must select the host or target port to trigger the fast import process.
- The tag is from 1 through 8 alphanumeric characters.
- You can configure only one Speed tag on an FC router, and up to eight Enforce tags on an FC router. The maximum number of tags (Enforce and Speed) on an FC router is eight.
- Up to 500 Speed LSAN tags are supported.

## Configuring an Enforce LSAN tag

1. Log in to the FC router as admin.
2. Enter the following command to disable the FC router:

```
switchdisable
```

3. Enter the following command to create an Enforce LSAN tag:

```
fcrlsan --add -enforce tagname
```

The *tagname* variable is the name of the LSAN tag you want to create.

4. Enter the following command to enable the FC router:

```
switchenable
```

5. Change the names of the LSAN zones in the edge fabrics to incorporate the tag in the names.

```
sw0:admin> switchdisable
sw0:admin> fcrlsan --add -enforce enftag1
LSAN tag set successfully
sw0:admin> switchenable
```

## Configuring a Speed LSAN tag

1. Log in to the FC router as admin.
2. Enter the **fcrlsan --add -speed tagname** command to create a Speed LSAN tag:  
The *tagname* variable is the name of the LSAN tag you want to create.
3. Change the names of the LSAN zones in the edge fabrics to incorporate the tag in the names.
4. Choose the host or target port to trigger the fast import process.

The following example creates a Speed LSAN tag named "fasttag2".

```
switch:admin> fcrlsan --add -speed fasttag2
LSAN tag set successfully
```

## Removing an LSAN tag

When you remove an LSAN tag, the tag is deactivated so that LSAN zones with this tag in the name now behave as regular LSAN zones. Removing an LSAN tag does not remove the LSAN zone.

You must disable the switch before removing an Enforce LSAN tag. You do not need to disable the switch to remove a Speed LSAN tag.

1. Log in to the FC router as admin.
2. Enter the **fcrlsan --remove** command to remove an existing LSAN tag.

If you remove an Enforce LSAN tag, you must disable the switch first.

### Example of removing an Enforce LSAN tag

```
sw0:admin> switchdisable
sw0:admin> fcrlsan --remove -enforce enftag1
LSAN tag removed successfully
sw0:admin> switchenable
```

### Example of removing a Speed LSAN tag

```
sw0:admin> fcrlsan --remove -speed fasttag2
LSAN tag removed successfully
```

## Displaying the LSAN tag configuration

1. Log in to the FC router as admin.
2. Enter the `fcrlsan --show` command.

```
sw0:admin> fcrlsan --show -enforce
Total LSAN tags : 1
ENFORCE : enftag1
sw0:admin> fcrlsan --show -speed
Total SPEED tags : 1
SPEED : fasttag2
sw0:admin> fcrlsan --show -all
Total LSAN tags : 2
ENFORCE : enftag1
SPEED : fasttag2
```

## LSAN zone binding

LSAN zone binding is an optional, advanced feature that increases the scalability envelope for very large metaSANs.

Without LSAN zone binding, every FC router in the backbone fabric maintains the entire LSAN zone and device state database. The size of this database limits the number of FC routers and devices you can have.

With LSAN zone binding, each FC router in the backbone fabric stores only the LSAN zone entries of the remote edge fabrics that can access its local edge fabrics. The LSAN zone limit supported in the backbone fabric is not limited by the capability of one FC router. In addition, due to the lower LSAN count, the CPU consumption by the FC router is lower. If you configure the metaSAN such that the backbone fabric has two groups of FC routers and there is no LSAN zone sharing and device access between the two groups, the number of FC routers and devices supported in the backbone fabric can be higher.

The following figure shows a sample metaSAN with four FC routers in the backbone fabric. Without LSAN zone binding, each FC router in the backbone fabric would store information about LSAN zones 1, 2, 3, and 4.

FIGURE 84 LSAN zone binding

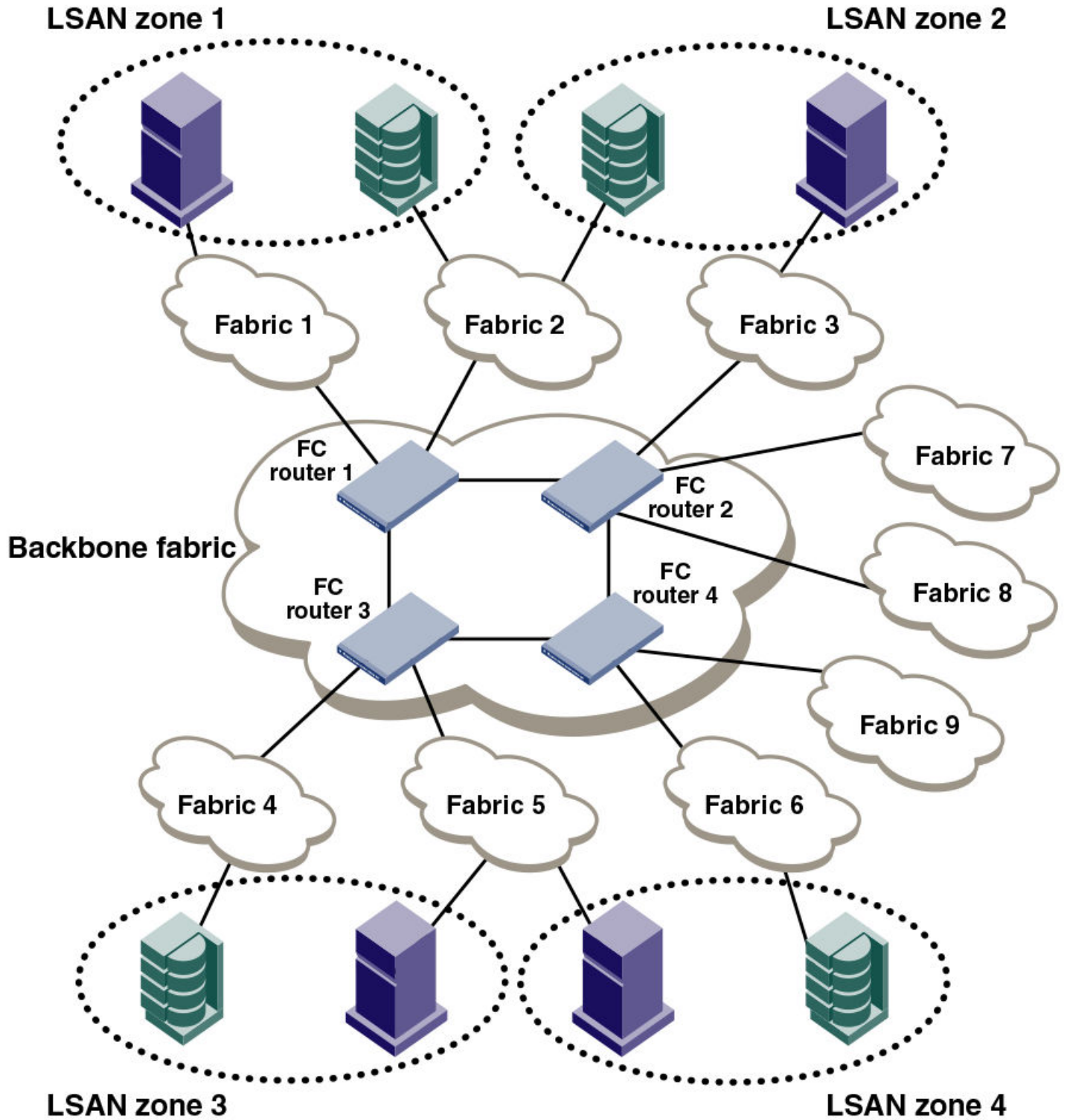

After you set up LSAN zone binding, each FC router stores information about only those LSAN zones that access its local edge fabrics. The following table shows what LSAN information is stored in each FC router before and after LSAN zone binding is in effect.

**TABLE 94** LSAN information stored in FC routers, with and without LSAN zone binding

Without LSAN zone binding				With LSAN zone binding					
FC router 1	FC router 2	FC router 3	FC router 4			FC router 1	FC router 2	FC router 3	FC router 4
LSAN 1	LSAN 1	LSAN 1	LSAN 1			LSAN 1	LSAN 2	LSAN 3	LSAN 4
LSAN 2	LSAN 2	LSAN 2	LSAN 2			LSAN 2		LSAN 4	
LSAN 3	LSAN 3	LSAN 3	LSAN 3						
LSAN 4	LSAN 4	LSAN 4	LSAN 4						

### LSAN zone binding considerations

- Without LSAN zone binding, the maximum number of LSAN devices is 10,000.
- With LSAN zone binding, the metaSAN can import more than 10,000 devices and the backbone fabric can support more FC routers.
- With LSAN zone binding, CPU consumption by an FC router is lower.

### How LSAN zone binding works

LSAN zone binding uses an *FC router matrix*, which specifies pairs of FC routers in the backbone fabric that can access each other, and an *LSAN fabric matrix*, which specifies pairs of edge fabrics that can access each other.

You set up LSAN zone binding using the **fcrLsanMatrix** command. This command has two options: **-fcr** and **-lsan**. The **-fcr** option is for creating and updating the FC router matrix, and the **-lsan** option is used for creating and updating the LSAN fabric matrix.

#### NOTE

**Best practice:** Use the LSAN zone binding feature in a backbone fabric in which all FC routers are running Fabric OS v6.1.0 or later.

When you set up LSAN zone binding on the local FC router (running Fabric OS v6.1.0 or later), the resultant matrix database is automatically distributed to all of the Fabric OS v6.1.0 or later FC routers in the backbone fabric. You do not need to set up LSAN zone binding on the other FC routers unless those FC routers are running Fabric OS versions earlier than v6.1.0.

If a new FC router joins the backbone fabric, the matrix database is automatically distributed to that FC router unless it has a different LSAN fabric matrix or FC router matrix or both defined already.

Note the following for FC routers running a Fabric OS version earlier than 6.1.0:

- The matrix database is not automatically distributed from this FC router to other FC routers.
- You must manually configure the LSAN fabric matrix on these FC routers to match the other FC routers in the backbone fabric.

If you have a dual backbone configuration, where two backbone fabrics share edge fabrics, the LSAN fabric matrix and FC router matrix settings for the shared edge fabrics must be the same on both backbone fabrics. The matrix databases are *not* automatically propagated from one backbone fabric to another, so you must ensure that both backbone fabrics have the same matrix settings.

#### NOTE

You can use LSAN zone binding along with LSAN tagging to achieve better scalability and performance. Refer to [LSAN zone policies using LSAN tagging](#) on page 523 for information about using the Enforce LSAN tag.

## FC router matrix definition

Depending on the structure of the backbone fabric, you can specify pairs of FC routers that can access each other. For the metaSAN shown in [Figure 84](#) on page 529, the following FC routers can access each other:

- FC router 1 and FC router 2
- FC router 3 and FC router 4

Because there is no device sharing between the two groups of FC routers, you can use the **fcrLsanMatrix** command with the **-fcr** option to create the corresponding FC router matrix:

```
fcrLsanmatrix --add -fcr wwn1 wwn2
fcrLsanmatrix --add -fcr wwn3 wwn4
```

The variables *wwn1*, *wwn2*, *wwn3*, and *wwn4* are the WWNs of the four FC routers.

Now edge fabrics 1, 2, 3, 7, and 8 can access each other, and edge fabrics 4, 5, 6, and 9 can access each other; however, edge fabrics in one group cannot access edge fabrics in the other group. The edge fabrics can still communicate with the backbone fabric.

## LSAN fabric matrix definition

With LSAN zone binding, you can specify pairs of fabrics that can access each other. Using the metaSAN shown in [Figure 84](#) on page 529 as an example, the following edge fabrics can access each other:

- Fabric 1 and Fabric 2
- Fabric 2 and Fabric 3
- Fabric 4 and Fabric 5
- Fabric 5 and Fabric 6

You can use the **fcrLsanMatrix** command with the **-lsan** option to create the corresponding LSAN fabric matrix:

```
fcrLsanmatrix --add -lsan 1 2
fcrLsanmatrix --add -lsan 2 3
fcrLsanmatrix --add -lsan 4 5
fcrLsanmatrix --add -lsan 5 6
```

Fabrics that are not specified are part of the default binding and can access other edge fabrics that are not specified. Thus, fabrics 7, 8, and 9 can access each other, but cannot access fabrics 1 through 6.

### ATTENTION

The **fcrLsanMatrix --add -lsan 0 0** command will erase the entire LSAN fabric matrix settings in the cache.

The FC router matrix and the LSAN fabric matrix are used together to determine which fabrics can access each other, with the LSAN fabric matrix providing more specific binding.

## Setting up LSAN zone binding

1. Log in to the FC router as admin.
2. Enter the following command to add a pair of FC routers that can access each other:

```
FCR:Admin> fcrLsanmatrix --add -fcrwwn1 wwn2
```

The variables *wwn1* and *wwn2* are the WWNs of the FC routers.

3. Enter the following command to add a pair of edge fabrics that can access each other:

```
FCR:Admin> fcrLsanmatrix --add -lsan fid1fid2
```

The variables *fid1* and *fid2* are the fabric IDs of the edge fabrics.

4. Enter the following command to apply the changes persistently:

```
FCR:Admin> fcrlsanmatrix --apply -all
```

```
FCR:Admin> fcrlsanmatrix --add -fcr 10:00:00:60:69:c3:12:b2 10:00:00:60:69:c3:12:b3
FCR:Admin> fcrlsanmatrix --add -lsan 4 5
FCR:Admin> fcrlsanmatrix --add -lsan 4 7
FCR:Admin> fcrlsanmatrix --add -lsan 10 19
FCR:Admin> fcrlsanmatrix --apply -all
```

## Viewing the LSAN zone binding matrixes

1. Log in to the FC router as admin.
2. Enter the following command to view the FC router matrix:

```
fcrlsanmatrix --fabricview -fcr
```

3. Enter the following command to view the LSAN fabric matrix:

```
fcrlsanmatrix --fabricview -lsan
```

```
FCR:Admin> fcrlsanmatrix --fabricview -fcr
SAVED FCR PAIRS
=====
FCR                                     FCR
-----
10:00:00:60:69:c3:12:b2 (2)             10:00:00:60:69:c3:12:b3 (unknown)
FCR:Admin> fcrlsanmatrix --fabricview -lsan
LSAN MATRIX is activated
Fabric ID      Fabric ID
-----
      4          5
      4          7
     10         19
```

## Location embedded LSAN zones

Starting with Fabric OS 7.4.0, location embedded LSAN zones help to increase the limit of LSAN zones in the backbone fabric by providing a mechanism to store only the applicable LSAN zones in each FC router. You can configure the LSAN zones appropriately in the edge fabric, at the same time retaining all the FC router features and characteristics such as any-to-any connectivity. You can have more than 10,000 LSAN devices in the entire backbone fabric or metaSAN.

Prior to Fabric OS 7.4.0, every FC router switch in the backbone fabric maintains the entire LSAN database having all LSAN zone entries in all edge fabrics subject to the maximum LSAN zone limit. In many cases, the device sharing is done between a few edge fabrics and not with all the edge fabrics that are connected in the backbone. The location embedded LSAN zones feature allows you to specify or embed the remote fabric ID in the LSAN zone names that share devices. The FC router uses the location information embedded in the LSAN zone name to store only relevant LSAN zone entries. The advantage is that an individual FC router stores less LSAN zone entries and allows you to configure more LSAN zones per FC router which helps to exceed the maximum LSAN zone limit across the backbone fabric.

### NOTE

In a backbone fabric having a mix of Fabric OS 7.4.0 and previous releases, there can be mismatch in location embedded LSAN zones in FC routers running Fabric OS pre-v7.4.0. Hence, such mixed combination is not recommended for this feature.

With location embedded LSAN zones, the FC router stores less LSAN zones, resulting in improved zone lookup during pair matching.



## Creating location embedded LSAN zones

To create location embedded LSAN zones, complete the following steps:

1. Identify the location and use the **portCfgExport** command to get the remote fabric ID that needs to be embedded in the LSAN zone.
2. Specify the location in the zone name along with the RFID tag.

```
LSAN_RFID_100
LSAN_LOCAL_SITE_RFID_4
```

- If you want to embed the RFID tag in the middle of the zone name, then the underscore (\_) character should be placed before the RFID tag and also appended after the valid fabric ID, as shown in the following example:

```
LSAN_SPEED_NEW_SITE_RFID_20_ZONENAME
```

- The RFID tag should be appended after the enforce and speed tags in case you need to use the enforce and the speed tags along with the RFID tag.

```
LSAN_ENFORCE1_RFID_100
LSAN_SPEED12_RFID_4_SITENAME
```

### NOTE

In the FC router, avoid using the RFID tag for configuring enforce or speed tags.

- The priority of processing in the FC router for zones having both enforce and RFID tags is as follows:
  1. The FC router will process the LSAN zones based on enforce tags during zone merge. Zones not matching these tags will be dropped.
  2. The LSAN distribution between FC routers based on RFID will be done only on the filtered zones obtained from step a.

### NOTE

Speed tags remain unaffected during this process.

3. Rename the LSAN zones in the paired edge fabric.

## Example configuration

FIGURE 85 Sample location embedded LSAN zones environment

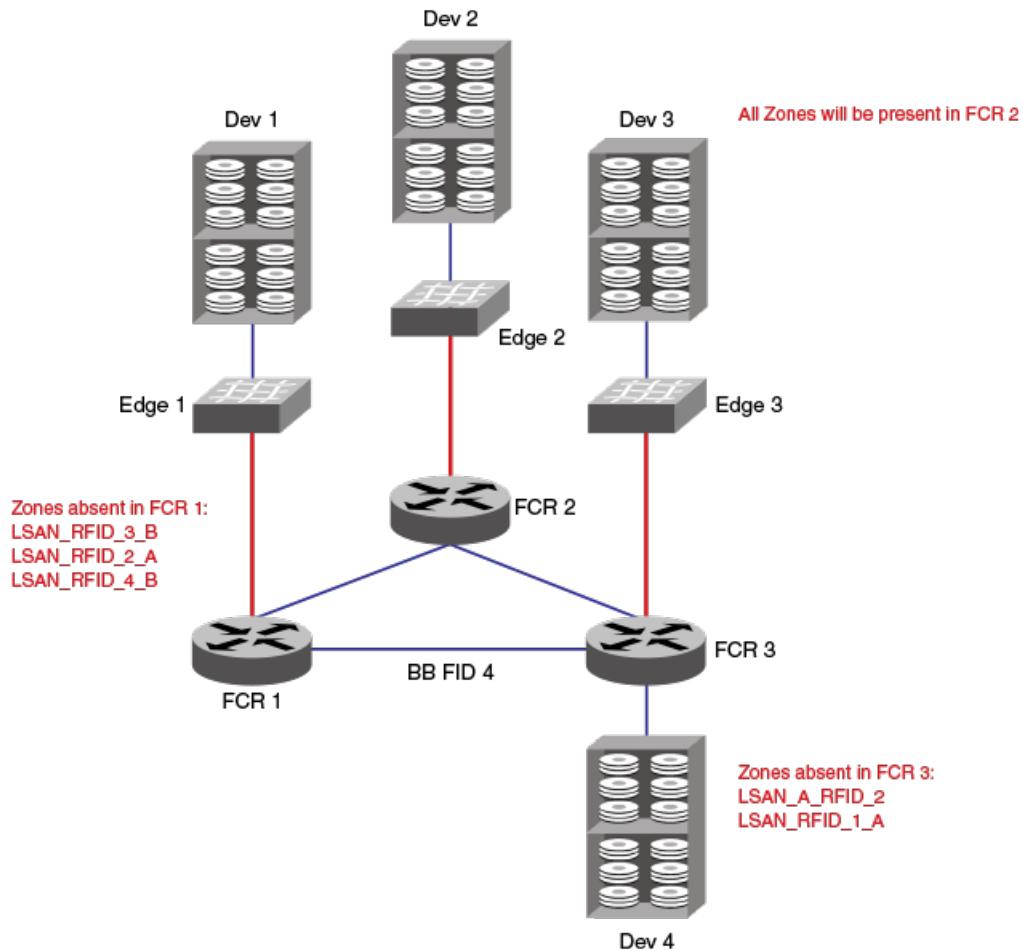

The following are the LSAN configurations made in the respective fabrics.

```
FID 1: LSAN_A : dev1 dev2      FID 3: LSAN_A : dev3 dev2
FID 1: LSAN_B : dev1 dev4      FID 3: LSAN_B : dev3 dev4
FID 2: LSAN_A : dev2 dev1      FID 4: LSAN_A : dev4 dev1
FID 2: LSAN_B : dev2 dev3      FID 4: LSAN_B : dev3 dev4
```

After you change the zone name by embedding the remote fabric ID and re-enabling the zone configuration in all the fabrics, LSAN zone configuration changes to the following:

```
FID 1: LSAN_A_RFID_2: dev1 dev2  FID 3: LSAN_RFID_2_A: dev3 dev2
FID 1: LSAN_B_RFID_4: dev1 dev4  FID 3: LSAN_RFID_4_B: dev3 dev4
FID 2: LSAN_RFID_1_A: dev2 dev1  FID 4: LSAN_A_RFID_1: dev4 dev1
FID 2: LSAN_RFID_3_B: dev2 dev3  FID 4: LSAN_B_RFID_3: dev3 dev4
```

FCR 1 has the following zones:

```
FID 1: LSAN_A_RFID_2: dev1 dev2
FID 1: LSAN_B_RFID_4: dev1 dev4
FID 2: LSAN_RFID_1_A: dev2 dev1
FID 4: LSAN_A_RFID_1: dev4 dev1
FID 4: LSAN_B_RFID_3: dev3 dev4
FID 3: LSAN_B_RFID_4: dev3 dev4
```

FCR 2 has the following zones:

```
FID 2: LSAN_RFID_1_A: dev2 dev1
FID 2: LSAN_RFID_3_B: dev2 dev3
FID 1: LSAN_A_RFID_2: dev1 dev2
FID 1: LSAN_B_RFID_4: dev1 dev4
FID 4: LSAN_A_RFID_1: dev4 dev1
FID 4: LSAN_B_RFID_3: dev3 dev4
FID 3: LSAN_RFID_2_A: dev3 dev2
FID 3: LSAN_RFID_4_B: dev3 dev4
```

FCR 3 has the following zones:

```
FID 3: LSAN_RFID_2_A: dev3 dev2
FID 3: LSAN_RFID_4_B: dev3 dev4
FID 2: LSAN_RFID_3_B: dev2 dev3
FID 4: LSAN_A_RFID_1: dev4 dev1
FID 4: LSAN_B_RFID_3: dev3 dev4
FID 1: LSAN_B_RFID_4: dev1 dev4
```

## Migrating LSAN zones to location embedded LSAN zones in the edge fabric

You must identify a set of LSAN zones for which you want to embed the location. For such LSAN zones, you must reconfigure the LSAN zones in the edge fabric by completing the following steps. Using this procedure, you can scale beyond the maximum limits in the metaSAN.

1. In the FC router running a release prior to Fabric OS 7.4.0, use the **lsanZoneShow -d -f <fid>** command to find the remote fabric ID from which devices are imported for each LSAN zone per configured edge fabric.
2. Rename the LSAN zone name by appending the special **\_RFID\_**"imported FID" tag.
3. If the LSAN zone has the devices that are imported from more than one edge fabric, split them into multiple LSAN zones based on the number of imported fabrics in **RFID\_**"imported FID" tag format and ensure that all newly created LSAN zones have only those imported device pairs.
4. Once all the LSAN zones are converted into **RFID\_**imported FID format, enable the zone configuration.
5. Repeat the previous steps in all the edge fabrics.  
LSAN zones that are not configured with location information will operate as per legacy FC router behavior.

## Limitations of location embedded LSAN zones

- Each FC router has different LSAN zones based on the location embedded in the LSAN zone name. If each FC router has 5000 LSANs, after firmware downgrade to a pre-7.4.0 version, any disruptive action in the metaSAN triggers import or export issues because the pre-7.4.0 FC router accepts only the first 5000 LSAN zones. In such an FC router, you will notice the RAS log FCR-1020 indicates that the FC router LSAN zones are exhausted. Also, the filter will apply depending on where the pre-7.4.0 switch is in the backbone fabric.
- The location embedded LSAN zone feature is not applicable for backbone-to-edge fabric LSAN zones. If you configure an RFID in a backbone fabric LSAN zone, it will not impact anything on resource utilization.
- The entries of **fcrProxyDevShow -a**, **fcrPhyDevShow -a**, and **lsanZoneShow** may not be same across FC routers in the backbone fabric.

- If you need to change the fabric ID for an EX\_Port whose FID is already being used as an RFID value in other edge fabric LSAN zones, you must modify the LSAN zone configuration to new a RFID value. The recommended steps are as follows:
  1. Disable the EX\_Ports that need an FID change.
  2. Configure the EX\_Ports with the new FID value.
  3. Enable the zone configuration in the respective edge fabrics with the new RFID value.
  4. Enable the EX\_Ports that were disabled in step 1.
- If you configure Backbone Fabric ID value for the RFID field, the LSAN zone is treated as regular LSAN zone and will be distributed to other FCRs in the backbone fabric.

## Peer LSAN zone support

Starting with Fabric OS 7.4.0, the FC router supports the peer LSAN zones if you have configured them in the edge fabric. Peer zoning rules are applied by the edge fabric switch. The FC router treats peer LSAN zones as normal LSAN zones and imports the devices in the edge fabric as per a pair-matching algorithm. RSCNs of proxy devices present in peer zones generated by the FC router are distributed to the edge fabric switches and controlled by the edge fabric name server as per peer zoning rules. The FC Router supports peer LSAN zones configured in a backbone fabric.

For more details, refer to [Peer Zoning](#) on page 340.

### NOTE

Initial WWNs starting with '00' are for internal use only and are auto-created. From Fabric OS 7.3.0 onwards, zones having such initial WWNs are treated as peer zones. If you upgrade the firmware from pre-7.3.0, or merge with a switch that has pre-7.3.0 firmware, or download configuration from pre-7.3.0 switch, and the first zone member WWN starts with '00', Fabric OS treats the zone as a peer zone. Please delete such invalid zones by first using the **cfgRemove** command, then the **zoneDelete** command and finally the **cfgSave/cfgEnable** commands.

### NOTE

If you are using peer zone over FC router, both edges or backbones should use peer zone. You cannot combine regular LSAN zone on one end with a peer LSAN zone on another end. Peer zone over FC router is not supported with NOS edge.

## Proxy PID configuration

When an FC router is first configured, the PIDs for the proxy devices are automatically assigned. Proxy PIDs (as well as phantom domain IDs) persist across reboots.

The most common situation in which you would set a proxy PID is when you replace a switch. If you replace the switch and want to continue using the old PID assignments, you can configure it to do so; this value remains in the system even if the blade is replaced. To minimize disruption to the edge fabrics, set the proxy PIDs to the same values used with the old hardware.

The **fcrProxyConfig** command displays or sets the persistent configuration of proxy devices. Used with the **-s** option, it can also influence the assignment of the xlate domain port number (which is used to determine the Area\_ID field of the PID) and the Port\_ID field. Like the PIDs in a fabric, a proxy PID must be unique. If the *slot* argument results in a duplicate PID, it will be ignored. Proxy PIDs are automatically assigned to devices imported into a fabric, starting at f001.

Use the **fcrXlateConfig** command to display or assign a preferred domain ID to a translate domain.

## Fabric parameter considerations

By default, EX\_Ports and VEX\_Ports detect, autonegotiate, and configure the fabric parameters without user intervention. You can optionally configure these parameters manually.

- To change the fabric parameters on a switch in the edge fabric, use the **configure** command.  
Note that to access all of the fabric parameters controlled by this command, you must disable the switch using the **switchDisable** command. If executed on an enabled switch, only a subset of attributes is configurable.
- To change the fabric parameters of an EX\_Port on the FC router, use the **portCfgEXPort** command.
- To change the fabric parameters of a VEX\_Port, use the **portCfgVEXPort** command.

The backbone fabric PID mode and the edge fabric PID mode do not need to match, but the PID mode for the EX\_Port or VEX\_Port and the edge fabric to which it is attached must match. You can statically set the PID mode for the fabric by using the **-p** option with the **portCfgEXPort** command. Use the **-t** option to disable the negotiate fabric parameter feature; otherwise, the PID mode is autonegotiated. The various edge fabrics may have different PID modes.

Fabric parameter settings, namely, E\_D\_TOV (error-detect timeout value), R\_A\_TOV (resource-allocation timeout value), and PID format, must be the same on EX\_Ports or VEX\_Ports and on the fabrics to which they are connected. You can set the PID format on an EX\_Port when you configure an inter-fabric link.

The default values for E\_D\_TOV and R\_A\_TOV for an EX\_Port or VEX\_Port must match those values on other Fabric OS switches. You do not need to adjust these parameters for an EX\_Port or VEX\_Port unless you have adjusted them for the edge fabric.

The default values for R\_A\_TOV and E\_D\_TOV are the recommended values for all but very large fabrics (ones requiring four or more hops) or high-latency fabrics (such as ones using long-distance FCIP links).

## Inter-fabric broadcast frames

The FC router can receive and forward broadcast frames between edge fabrics and between the backbone fabric and edge fabrics. Many target devices and HBAs cannot handle broadcast frames. In this case, you can set up broadcast zones to control which devices receive broadcast frames. (Refer to [Broadcast zones](#) on page 303 for information about setting up broadcast zones.)

By default, broadcast frames are *not* forwarded from the FC router to the edge fabrics.

## Displaying the current broadcast configuration

1. Log in to the FC router as admin.
2. Enter the following command:

```
fcr:admin> fcrbcstconfig --show
```

This command displays only the FIDs that have the broadcast frame option enabled. The FIDs that are not listed have the broadcast frame option disabled.

## Enabling broadcast frame forwarding

1. Log in to the FC router as admin.
2. Enter the following command:

```
fcr:admin> fcrbcstconfig --enable -f fabricID
```

The *fabricID* variable is the FID of the edge or backbone fabric on which you want to enable broadcast frame forwarding. Broadcast frame forwarding is enabled by default.

## Disabling broadcast frame forwarding

1. Log in to the FC router as admin.
2. Enter the following command:

```
fcr:admin> fcrbcastconfig --disable -f fabricID
```

The *fabricID* variable is the FID of the edge or backbone fabric on which you want to disable broadcast frame forwarding.

## Resource monitoring

It is possible to exhaust resources, such as proxy PIDs. Whenever a resource is exhausted, Fabric OS generates an error message. The messages are described in the *Fabric OS Message Reference*.

You can monitor FC router resources using the **fcrresourceshow** command. This command shows FC router resource limits and usage and includes the following:

- **LSAN zones and LSAN devices** —The information shows the maximum versus the currently used zones and device database entries. Each proxy or physical device constitutes an entry. If LSAN zones are defined in two edge fabrics, they are counted as two and not one. One device imported into multiple edge fabrics counts multiple times.  
The default maximum number of LSAN zones is 3,000. Refer to [Setting the maximum LSAN count](#) on page 522 for information on changing this limit.
- **Proxy Device Slots** — The physical and proxy devices use the 10,000 device slots.  
The information shows the maximum pool size for translate phantom node and port WWNs and shows the number of translate node and port WWNs from this pool.
- **Phantom Node WWNs**
- **Phantom Port WWNs**
- **Max proxy devices**
- **Max NR\_Ports**

The following example shows the use of the **fcrresourceshow** command to display physical port (EX\_Port) resources.

```
switch:admin> fcrresourceshow
Daemon Limits:
                Max Allowed      Currently Used
-----
LSAN Zones:    3000                28
LSAN Devices:  10000               51
Proxy Device Slots: 10000            20

                WWN Pool Size      Allocated
-----
Phantom Node WWN: 8192                5413
Phantom Port WWN: 32768            16121

Port Limits:
Max proxy devices: 4000
Max NR_Ports:    1000

Currently Used(column 1: proxy, column 2: NR_Ports):
0 |          0          34
1 |          3          34
4 |          0           0
5 |          0           0
6 |          0           0
7 |          0           0
8 |          6          34
9 |          6          34
```

10	6	34
11	6	34
12	6	34
13	6	34
14	6	34
15	6	34
16	8	34
17	8	34
18	8	34
19	8	34
20	8	34
21	8	34
22	8	34
23	8	34

## FC-FC routing and Virtual Fabrics

If Virtual Fabrics is not enabled, FC-FC routing behavior is unchanged. If Virtual Fabrics is enabled, then in the FC-FC routing context, a base switch is like a backbone switch and a base fabric is like a backbone fabric.

If Virtual Fabrics is enabled, the following rules apply:

- EX\_Ports and VEX\_Ports can be configured only on the base switch.

When you enable Virtual Fabrics, the chassis is automatically rebooted. When the switch comes up, only one default logical switch is present, with the default fabric ID (FID) of 128. All previously configured EX\_Ports and VEX\_Ports are persistently disabled with the reason *ExPort in non base switch*. You must explicitly create a base switch, move the EX\_Ports and VEX\_Ports to the base switch, and then enable the ports.

If you move existing EX\_Ports or VEX\_Ports to any logical switch other than the base switch, these ports are automatically disabled.

If you want to change an EX\_Port or VEX\_Port on the logical switch to be a non-EX\_Port or VEX\_Port, you must use the **portCfgDefault** command. You cannot use the **portCfgExPort** command because that command is allowed only on the base switch.

- EX\_Ports can connect to a logical switch that is in the same chassis or in a different chassis. However, the following configuration rules apply:
  - If the logical switch is on the same chassis, the EX\_Port FID must be set to a different value than the FID of the logical switch to which it is connecting.
  - If the logical switch is on a different chassis, no FID for any logical switch in the FC router backbone fabric can be the same as the FID of the logical switch to which the EX\_Port is connecting.
- EX\_Ports and VEX\_Ports in FC routers and those in a base switch cannot connect to any edge fabric with logical switches configured to use XISLs.

If you connect an EX\_Port or VEX\_Port to an edge fabric, you must ensure that there are no logical switches with XISL use enabled in that edge fabric. If any logical switch in the edge fabric allows XISL use, then the EX\_Port or VEX\_Port is disabled. Refer to [Configuring a logical switch for XISL use](#) on page 292 for instructions on disallowing XISL use.

Because XISL use is disallowed, dedicated links must be configured to route traffic across switches in the same logical fabric.

### ATTENTION

If you connect an EX\_Port or VEX\_Port from an FC router running Fabric OS v6.1.x or earlier to a logical switch that allows XISL use, the EX\_Port or VEX\_Port is *not* disabled. However, this configuration is not supported.

- Backbone-to-edge routing is not supported in the base switch. Refer to [Figure 23](#) on page 274 for information about how to configure legacy FC routers to allow backbone-to-edge routing with Virtual Fabrics.

- All FC router commands can be executed only in the base switch context.
- The **fcrConfigure** command is not allowed when Virtual Fabrics is enabled. Instead, use the **IsCfg** command to configure the FID.
- Although the Brocade 6510 and 6520 support up to four logical switches, if you are using FC-FC routing, they can have a maximum of only three logical switches.
- In the Brocade 7840, FC-FC routing is not supported on the base switch.
- When a VF enabled switch is part of backbone, only the base switch will be able to route frames between edge fabrics. If any other (default or logical) switch is included as a hop between edge fabrics, packets will be dropped.

## Logical switch configuration for FC routing

Figure 86 shows an example of two chassis partitioned into logical switches. This configuration allows the device in Fabric 128 to communicate with the device in Fabric 15 without merging the fabrics.

The following conditions are considered:

- The base switch in Physical chassis 1 serves as an FC router and contains EX\_Ports that connect to logical switches in the two edge fabrics, Fabric 128 and Fabric 15.
- The other logical switches in Fabric 128 and Fabric 15 must be connected with physical ISLs, and do not use the XISL connection in the base fabric.
- The logical switches in Fabric 1 are configured to allow XISL use. You cannot connect an EX\_Port to these logical switches, so the device in Fabric 1 cannot communicate with the other two devices.

FIGURE 86 EX\_Ports in a base switch

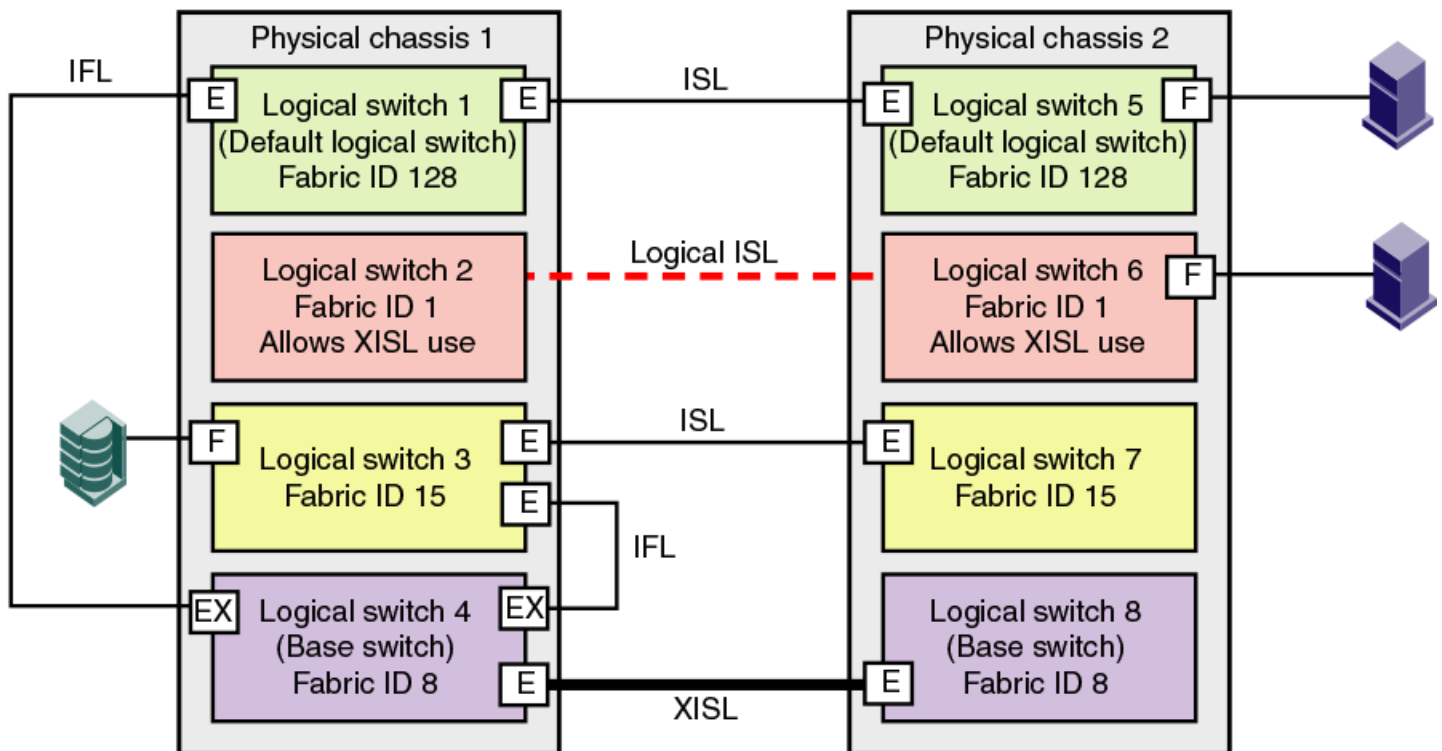
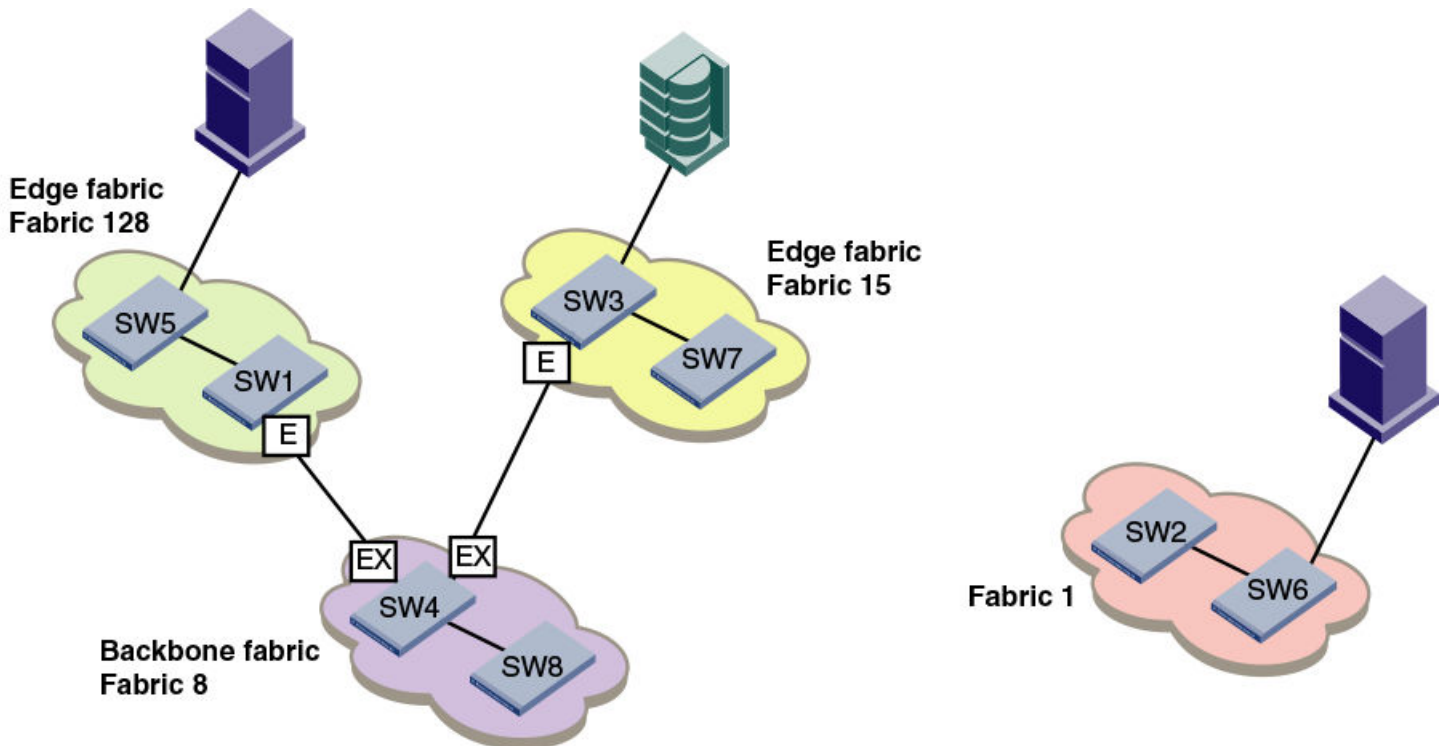



Figure 87 shows a logical representation of the physical chassis and devices in Figure 86. As shown in Figure 87, Fabric 128 and Fabric 15 are edge fabrics connected to a backbone fabric. Fabric 1 is not connected to the backbone, so the device in Fabric 1 cannot communicate with any of the devices in the other fabrics.

FIGURE 87 Logical representation of EX\_Ports in a base switch



## Backbone-to-edge routing with Virtual Fabrics

Backbone-to-edge routing is not supported in the base switch, unless you use a legacy FC router. A *legacy FC router* is an FC router configured on a Brocade 7500 switch.

Base switches can participate in a backbone fabric with legacy FC routers. You cannot connect devices to the base switch because the base switch does not allow F\_Ports. You can, however, connect devices to the legacy FC router, thus enabling backbone-to-edge routing.

If you connect a legacy FC router to a base switch, you must set the backbone FID of the FC router to be the same as that of the base switch.

In Figure 86 on page 540, no devices can be connected to the backbone fabric (Fabric 8) because base switches cannot have F\_Ports. Figure 88 shows an FC router in legacy mode connected to a base switch. This FC router *can* have devices connected to it, and so you can have backbone-to-edge routing through this FC router. In this figure, Host A in the backbone fabric can communicate with device B in the edge fabric with FID 20; Host A cannot communicate with device C, however, because the base switches do not support backbone-to-edge routing.

FIGURE 88 Backbone-to-edge routing across base switch using FC router in legacy mode

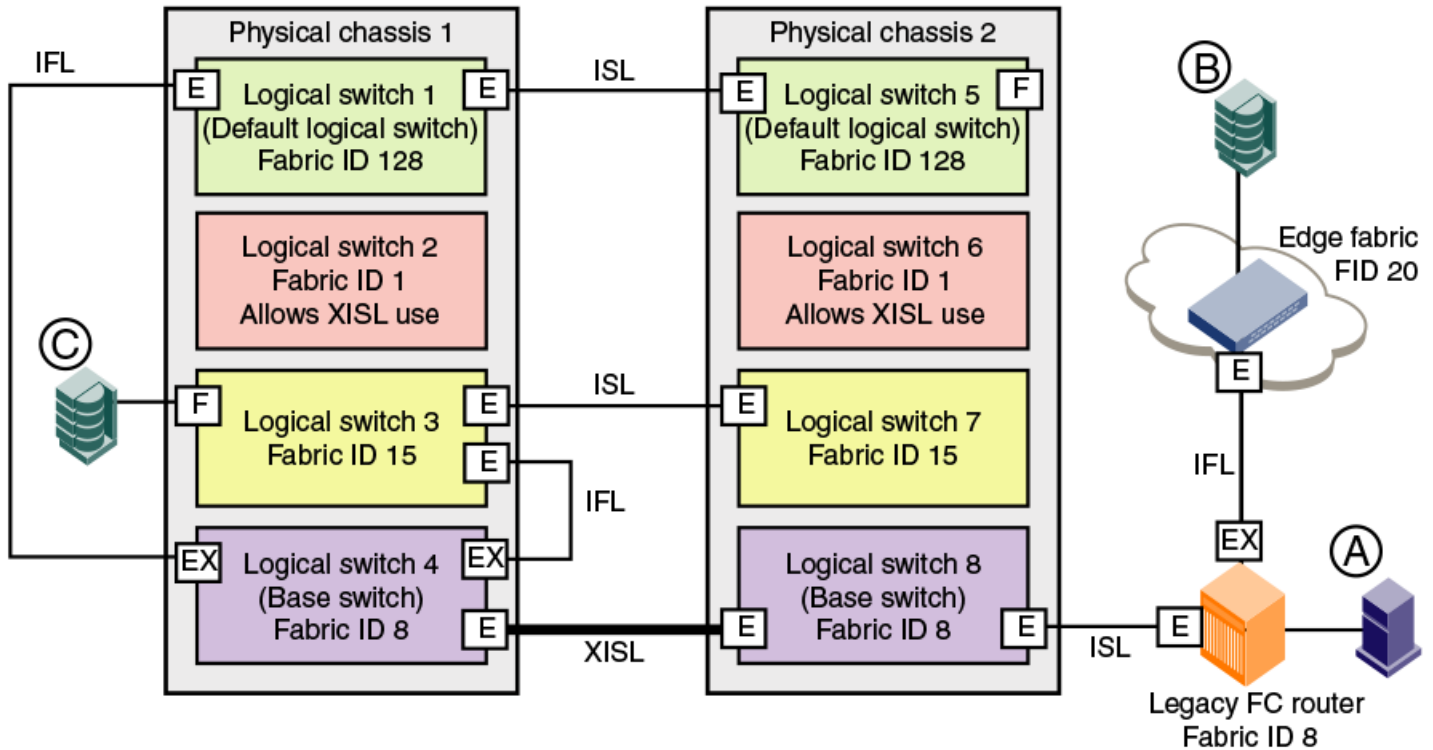

If a backbone fabric has both a Virtual Fabrics-enabled FC router and a Virtual Fabrics-disabled FC router, EX\_Ports are not allowed from the base switch of the Virtual Fabrics-enabled FC router to the same edge fabric that is performing backbone-to-edge routing with the Virtual Fabrics-disabled FC router.

For example, in the above figure, you should not connect EX\_Ports from the base switch (logical switch 4 or logical switch 8) to the edge fabric FID 20, which is performing backbone-to-edge routing with a legacy FC router.

## Upgrade and downgrade considerations for FC-FC routing

When you upgrade to Fabric OS v7.0.0 or later, EX\_Ports remain functional and you can continue to perform all FC router operations on the switch.

Brocade recommends that you save your FC-FC routing configuration (using the `configUpload` command) before performing any downgrades.

Before upgrading the Brocade G620 switch from Fabric OS 8.0.0 to 8.0.1, ensure that an Integrated Routing License is installed if EX\_Port is enabled in the switch. This avoids EX\_Port getting disabled after upgrade.

## How replacing port blades affects EX\_Port configuration

If you replace an FR4-18i blade with an 8-Gbps port blade or FX8-24 blade, the EX\_Port configuration remains the same for the first 16 ports on the 8-Gbps port blade (and for the first 12 FC ports on the FX8-24 blade). For all other ports on the blade, the EX\_Port configuration is cleared. No ports are persistently disabled.

If you replace an 8-Gbps port blade with an FX8-24 blade, the EX\_Port configuration remains the same for the first 12 FC ports on the FX8-24 blade.

If you replace an 8-Gbps port blade or FX8-24 blade with another 8-Gbps port blade, the EX\_Port configuration remains the same.

## Displaying the range of output ports connected to xlate domains

The edge fabric detects only one front domain from an FC router connected through multiple output ports. The output port of the front domain is not fixed to 0; the values can be in a range from 129 through 255. The range of the output ports connected to the xlate domain is from 1 through 128. This range enables the front domain to connect to 127 remote xlate domains.

1. Log in to a switch in the edge fabric.
2. Enter the **lsDbShow** command on the edge fabric.

In the **lsDbShow** output, ports in the range from 129 through 255 are the output ports on the front domain.

## Display the range of output ports

The following example shows the range of output ports.

```
linkCnt = 2,      flags = 0x0
LinkId = 53, out port = 1, rem port = 35, cost = 500, costCnt = 0, type = 1
LinkId = 57, out port = 129, rem port = 18, cost = 500, costCnt = 0, type = 1
```

## Display ports on edge fabric

The following example also shows the use of the **lsDbShow** display on the edge fabric. The front domain, domain 3, has two links representing two EX\_Port connections with output ports 129 and 132.

```
Domain = 3, Link State Database Entry pointer = 0x100bbcc0
.....
linkCnt = 4,      flags = 0x0
LinkId = 199, out port = 129, rem port = 2, cost = 10000, costCnt = 0, type = 1
LinkId = 199, out port = 132, rem port = 3, cost = 10000, costCnt = 0, type = 1
LinkId = 2, out port = 1, rem port = 2, cost = 10000, costCnt = 0, type = 1
LinkId = 1, out port = 32, rem port = 2, cost = 10000, costCnt = 0, type = 1
```



# Port Indexing

This section shows how to use the **switchShow** command to determine the mapping among the port index, slot or port numbers, and the 24-bit port ID (PID) on any Brocade Backbone. Enter the **switchShow** command without parameters to show the port index mapping for the entire platform. Enter the **switchShow -slot** command for port mapping information for the ports on the blade in a specific slot. Include the **--qsfp** option to list also the QSFP number, for slots that contain core blades.

This example shows the output of the **switchShow** command for a CR16-4 core blade in slot 3 of a Brocade DCX 8510-4 Backbone. The leftmost column shows the unique port index. The second and third columns show the corresponding physical slot and port numbers, respectively. The corresponding QSFP number for the port is also shown. For a core blade, no PID exists in the Address column.

```
switch:FID128:admin> switchshow -slot 3 -qsfp

switchName: switch name
switchType: 121.3
switchState: Online
switchMode: Native
switchRole: Subordinate
switchDomain: 75
switchId: fffc4b
switchWwn: 10:00:00:05:1e:4f:eb:00
zoning: ON (zoning name)
switchBeacon: OFF
FC Router: OFF
HIF Mode: ON
Allow XISL Use: OFF
LS Attributes: [FID: 128, Base Switch: No, Default Switch: Yes, Address Mode 0]
=====
Index  Slot  Port  QSFP  Address  Media  Speed  State  Proto
=====
256   3    0    0     -----  id    16G    No_SigDet  FC
257   3    1    0     -----  id    16G    No_SigDet  FC
258   3    2    0     -----  id    16G    No_SigDet  FC
259   3    3    0     -----  id    16G    No_SigDet  FC
260   3    4    1     -----  --    16G    No_Module  FC
261   3    5    1     -----  --    16G    No_Module  FC
262   3    6    1     -----  --    16G    No_Module  FC
263   3    7    1     -----  --    16G    No_Module  FC
264   3    8    2     -----  --    16G    No_Module  FC
265   3    9    2     -----  --    16G    No_Module  FC
266   3   10    2     -----  --    16G    No_Module  FC
267   3   11    2     -----  --    16G    No_Module  FC
268   3   12    3     -----  --    16G    No_Module  FC
269   3   13    3     -----  --    16G    No_Module  FC
270   3   14    3     -----  --    16G    No_Module  FC
271   3   15    3     -----  --    16G    No_Module  FC
736   3   16    4     -----  --    16G    No_Module  FC
737   3   17    4     -----  --    16G    No_Module  FC
738   3   18    4     -----  --    16G    No_Module  FC
739   3   19    4     -----  --    16G    No_Module  FC
740   3   20    5     -----  --    16G    No_Module  FC
741   3   21    5     -----  --    16G    No_Module  FC
742   3   22    5     -----  --    16G    No_Module  FC
743   3   23    5     -----  --    16G    No_Module  FC
744   3   24    6     -----  --    16G    No_Module  FC
745   3   25    6     -----  --    16G    No_Module  FC
746   3   26    6     -----  --    16G    No_Module  FC
747   3   27    6     -----  --    16G    No_Module  FC
748   3   28    7     -----  id    16G    Online     FC E-Port 10:00:00:05:1e:39:e4:5a
trunkmaster name (Trunk master)
749   3   29    7     -----  id    16G    Online     FC E-Port 10:00:00:05:1e:39:e4:5a
trunkmaster name (Trunk master)
750   3   30    7     -----  id    16G    Online     FC E-Port 10:00:00:05:1e:39:e4:5a
trunkmaster name (Trunk master)
```

```

751      3      31      7      -----      id      16G      Online      FC E-Port 10:00:00:05:1e:39:e4:5a
trunkmaster name (Trunk master)

```

This example shows the truncated output of the **switchShow** command for an FC16-32 port blade in slot 1 of a Brocade DCX 8510-8 Backbone. The Address column shows the PID.

```

switch:FID128:admin> switchshow -slot 1

switchName: DCX8510_8
(output truncated)
LS Attributes: [FID: 128, Base Switch: No, Default Switch: Yes, Address Mode 0]
Index  Slot  Port  Address  Media  Speed  State  Proto
=====
0      1      0      500000  --     N16    No_Module  FC
1      1      1      500100  --     N16    No_Module  FC
2      1      2      500200  --     N16    No_Module  FC
(output truncated)

```

This example shows the truncated **switchShow** output for an FC16-64 port blade on the Brocade DCX 8510 Backbone. The assignment of port index numbers to PIDs will vary depending on blade type, platform type, and slot number.

```

DCX:admin> switchshow

Index  Slot  Port  Address  Media  Speed  State
=====
0      1      0      0a0040  --     N16    No_Module
1      1      1      0a0140  --     N16    No_Module
2      1      2      0a0240  --     N16    No_Module
(output truncated)
768    1      48     0a00c0  --     N16    No_Module
769    1      49     0a01c0  --     N16    No_Module
770    1      50     0a02c0  --     N16    No_Module
(output truncated)
784    1      62     0a0ec0  --     N16    No_Module
783    1      63     0a0fc0  --     N16    No_Module
16     2      0      0a1040  --     N16    No_Module
17     2      1      0a1140  --     N16    No_Module
(output truncated)

```

This example shows the truncated **switchShow** output for an FX8-24 application blade on the Brocade DCX 8510-8 Backbone. The assignment of port index numbers to PIDs will vary depending on blade type, platform type, and slot number.

```

switch:FID128:admin> switchshow -slot 10

switchName: my8510-8
(output truncated)
Slot  Blade  Type  ID  Model  Name  Status
-----
10    AP  BLADE  75  FX8-24  ENABLED
Index  Slot  Port  Address  Media  Speed  State  Proto
=====
80     10    0      505000  id     4G     No_Light  FC
81     10    1      505100  --     4G     No_Module  FC
82     10    2      505200  id     4G     Mod_Inv   FC "Speed Mismatch / Incompatible SFP"
83     10    3      505300  --     4G     No_Module  FC
84     10    4      505400  --     4G     No_Module  FC
(output truncated)
95     10    15     505f00  --     --     Offline   VE
208    10    16     50d000  --     --     Offline   VE
209    10    17     50d100  --     4G     Offline   VE
(output truncated)

```

# Switch and blade sensors

- [Brocade switch sensors.....](#) 547
- [Brocade blade temperature sensors.....](#) 547
- [System temperature monitoring.....](#) 548

## Brocade switch sensors

The following table lists the number of temperature sensors, fans, and PSUs for each Brocade switch model for Fabric OS 8.0.1. The "swNum / connUnitNum" column is the sum of the values in the previous three columns.

**TABLE 95** Brocade switch sensor counts

Platform	Temperature sensors	Fans	Power supply units	swNum / connUnitNum
Brocade 6505	4	2	2	8
Brocade 6510	4	2	2	8
Brocade 6520	4	2	2	8
Brocade G620	5	6	2	13
Brocade 7840 extension switch	4	5	2	11
Brocade DCX 8510-4 Director	35+	2	2	39+
Brocade DCX 8510-8 Director	58+	3	4	65+
Brocade X6-4 Director	35+	2	2	39+
Brocade X6-8 Director	58+	3	4 (3 minimum)	65+
Brocade M6505 Blade Server SAN I/O Module	3	0	0	3
Brocade 6543 Blade Server SAN I/O Module	2	0	0	2
Brocade 6545 Blade Server SAN I/O Module				
Brocade 6546 Blade Server SAN I/O Module	3	0	0	3
Brocade 6547 Blade Server SAN I/O Module	3	0	0	3
Brocade 6548 Blade Server SAN I/O Module	2	0	0	2
Brocade 6558 Blade Server SAN I/O Module	2	0	0	2

## Brocade blade temperature sensors

The following table lists the number of temperature sensors for each Brocade blade model supported in Fabric OS 8.0.1. Not all blades are supported in all chassis; refer to the release notes for the version of Fabric OS 8.0.1 you are working with for any restrictions or considerations.

**TABLE 96** Brocade blade temperature sensors

Model	Temperature sensors
FC16-32	5
FC16-48	5
FC16-64	5
FC32-48	5
FX8-24	3

**TABLE 96** Brocade blade temperature sensors (continued)

Model	Temperature sensors
SX6	7

## System temperature monitoring

Brocade blades, chassis, and fixed-port switches are continuously monitored for thermal safety. Fabric OS thermal policies are based on a matrix of sensor values particular to each device. Different versions of Fabric OS may also have different thermal policies, as these limits are determined by testing and real-world experience. For all Brocade devices, fan speeds alter to accommodate temperature changes. As a general rule, devices in danger of overheating will be shut down after a two-minute warning. The blades may shutdown sooner if the temperature continues to rise drastically.



# Hexadecimal Conversion

- [Hexadecimal overview](#)..... 549

## Hexadecimal overview

Hexadecimal, also known as hex, is a numeral system with a base of 16, usually written by means of symbols 0-9 and A-F (or a-f). Its primary purpose is to represent the binary code that computers interpret in a format easier for humans to remember. It acts as a form of shorthand, in which one hexadecimal digit takes the place of four binary bits. For example, the decimal numeral 79, with the binary representation of 01001111, is 4F (or 4f) in hexadecimal where 4 = 0100, and F = 1111.

Hexadecimal numbers can have either a *0x* prefix or a *ah* suffix. The address 0xFFFFFA is the same address as FFFFFA*h*. This type of address with 6 digits representing 3 bytes is called a hex triplet. Fibre Channel uses hexadecimal notation in hex triplets to specify well-known addresses and port IDs.

## Example conversion of the hexadecimal triplet 0x616000

Notice the PID (610600 - bolded) in the **nsShow** output is in hexadecimal.

```
switch:admin> nsshows
{
  Type Pid      COS      PortName      NodeName      TTL (sec)
  N
610600
;      2,3;10:00:00:00:c9:29:b3:84;20:00:00:00:c9:29:b3:84; na
  FC4s: FCP
  NodeSymb: [36] "Emulex LP9002 FV3.90A7 DV5-5.10A10 "
  Fabric Port Name: 20:08:00:05:1e:01:23:e0
  Permanent Port Name: 10:00:00:00:c9:29:b3:84
  Port Index: 6
  Share Area: No
  Device Shared in Other AD: No
  Redirect: No
  LSAN: Yes
      Device link speed: 8G
The Local Name Server has 1 entry }
```

1. Separate the 6 digits into triplets by inserting a space after every 2 digits: 61 06 00
2. Convert each hexadecimal value to a decimal representation:

61 = Domain ID = 97

06 = Area (port number) = 06

00 = Port (ALPA) = 0 (not used in this instance, but is used in loop, shared areas in PID assignments on blades, NPIV, and Access Gateway devices)

Result: hexadecimal triplet 610600 = decimal triplet 97,06,00

## Decimal-to-hexadecimal conversion table

Decimal	01	02	03	04	05	06	07	08	09	10
Hex	01	02	03	04	05	06	07	08	09	0a
Decimal	11	12	13	14	15	16	17	18	19	20
Hex	0b	0c	0d	0e	0f	10	11	12	13	14

<b>Decimal</b>	<b>21</b>	<b>22</b>	<b>23</b>	<b>24</b>	<b>25</b>	<b>26</b>	<b>27</b>	<b>28</b>	<b>29</b>	<b>30</b>
Hex	15	16	17	18	19	1a	1b	1c	1d	1e
<b>Decimal</b>	<b>31</b>	<b>32</b>	<b>33</b>	<b>34</b>	<b>35</b>	<b>36</b>	<b>37</b>	<b>38</b>	<b>39</b>	<b>40</b>
Hex	1f	20	21	22	23	24	25	26	27	28
<b>Decimal</b>	<b>41</b>	<b>42</b>	<b>43</b>	<b>44</b>	<b>45</b>	<b>46</b>	<b>47</b>	<b>48</b>	<b>49</b>	<b>50</b>
Hex	29	2a	2b	2c	2d	2e	2f	30	31	32
<b>Decimal</b>	<b>51</b>	<b>52</b>	<b>53</b>	<b>54</b>	<b>55</b>	<b>56</b>	<b>57</b>	<b>58</b>	<b>59</b>	<b>60</b>
Hex	33	34	35	36	37	38	39	3a	3b	3c
<b>Decimal</b>	<b>61</b>	<b>62</b>	<b>63</b>	<b>64</b>	<b>65</b>	<b>66</b>	<b>67</b>	<b>68</b>	<b>69</b>	<b>70</b>
Hex	3d	3e	3f	40	41	42	43	44	45	46
<b>Decimal</b>	<b>71</b>	<b>72</b>	<b>73</b>	<b>74</b>	<b>75</b>	<b>76</b>	<b>77</b>	<b>78</b>	<b>79</b>	<b>80</b>
Hex	47	48	49	4a	4b	4c	4d	4e	4f	50
<b>Decimal</b>	<b>81</b>	<b>82</b>	<b>83</b>	<b>84</b>	<b>85</b>	<b>86</b>	<b>87</b>	<b>88</b>	<b>89</b>	<b>90</b>
Hex	51	52	53	54	55	56	57	58	59	5a
<b>Decimal</b>	<b>91</b>	<b>92</b>	<b>93</b>	<b>94</b>	<b>95</b>	<b>96</b>	<b>97</b>	<b>98</b>	<b>99</b>	<b>100</b>
Hex	5b	5c	5d	5e	5f	60	61	62	63	64
<b>Decimal</b>	<b>101</b>	<b>102</b>	<b>103</b>	<b>104</b>	<b>105</b>	<b>106</b>	<b>107</b>	<b>108</b>	<b>109</b>	<b>110</b>
Hex	65	66	67	68	69	6a	6b	6c	6d	6e
<b>Decimal</b>	<b>111</b>	<b>112</b>	<b>113</b>	<b>114</b>	<b>115</b>	<b>116</b>	<b>117</b>	<b>118</b>	<b>119</b>	<b>120</b>
Hex	6f	70	71	72	73	74	75	76	77	78
<b>Decimal</b>	<b>121</b>	<b>122</b>	<b>123</b>	<b>124</b>	<b>125</b>	<b>126</b>	<b>127</b>	<b>128</b>	<b>129</b>	<b>130</b>
Hex	79	7a	7b	7c	7d	7e	7f	80	81	82
<b>Decimal</b>	<b>131</b>	<b>132</b>	<b>133</b>	<b>134</b>	<b>135</b>	<b>136</b>	<b>137</b>	<b>138</b>	<b>139</b>	<b>140</b>
Hex	83	84	85	86	87	88	89	8a	8b	8c
<b>Decimal</b>	<b>141</b>	<b>142</b>	<b>143</b>	<b>144</b>	<b>145</b>	<b>146</b>	<b>147</b>	<b>148</b>	<b>149</b>	<b>150</b>
Hex	8d	8e	8f	90	91	92	93	94	95	96
<b>Decimal</b>	<b>151</b>	<b>152</b>	<b>153</b>	<b>154</b>	<b>155</b>	<b>156</b>	<b>157</b>	<b>158</b>	<b>159</b>	<b>160</b>
Hex	97	98	99	9a	9b	9c	9d	9e	9f	a0
<b>Decimal</b>	<b>161</b>	<b>162</b>	<b>163</b>	<b>164</b>	<b>165</b>	<b>166</b>	<b>167</b>	<b>168</b>	<b>169</b>	<b>170</b>
Hex	a1	a2	a3	a4	a5	a6	a7	a8	a9	aa
<b>Decimal</b>	<b>171</b>	<b>172</b>	<b>173</b>	<b>174</b>	<b>175</b>	<b>176</b>	<b>177</b>	<b>178</b>	<b>179</b>	<b>180</b>
Hex	ab	ac	ad	ae	af	b0	b1	b2	b3	b4
<b>Decimal</b>	<b>181</b>	<b>182</b>	<b>183</b>	<b>184</b>	<b>185</b>	<b>186</b>	<b>187</b>	<b>188</b>	<b>189</b>	<b>190</b>
Hex	b5	b6	b7	b8	b9	ba	bb	bc	bd	be
<b>Decimal</b>	<b>191</b>	<b>192</b>	<b>193</b>	<b>194</b>	<b>195</b>	<b>196</b>	<b>197</b>	<b>198</b>	<b>199</b>	<b>200</b>
Hex	bf	c0	c1	c2	c3	c4	c5	c6	c7	c8
<b>Decimal</b>	<b>201</b>	<b>202</b>	<b>203</b>	<b>204</b>	<b>205</b>	<b>206</b>	<b>207</b>	<b>208</b>	<b>209</b>	<b>210</b>
Hex	c9	ca	cb	cc	cd	ce	cf	d0	d1	d2
<b>Decimal</b>	<b>211</b>	<b>212</b>	<b>213</b>	<b>214</b>	<b>215</b>	<b>216</b>	<b>217</b>	<b>218</b>	<b>219</b>	<b>220</b>
Hex	d3	d4	d5	d6	d7	d8	d9	da	db	dc
<b>Decimal</b>	<b>221</b>	<b>222</b>	<b>223</b>	<b>224</b>	<b>225</b>	<b>226</b>	<b>227</b>	<b>228</b>	<b>229</b>	<b>230</b>
Hex	dd	de	df	e0	e1	e2	e3	e4	e5	e6
<b>Decimal</b>	<b>231</b>	<b>232</b>	<b>233</b>	<b>234</b>	<b>235</b>	<b>236</b>	<b>237</b>	<b>238</b>	<b>239</b>	<b>240</b>

Hex	e7	e8	e9	ea	eb	ec	ed	ef	ee	f0
<b>Decimal</b>	<b>241</b>	<b>242</b>	<b>243</b>	<b>244</b>	<b>245</b>	<b>246</b>	<b>247</b>	<b>248</b>	<b>249</b>	<b>250</b>
Hex	f1	f2	f3	f4	f5	f6	f7	f8	f9	fa
<b>Decimal</b>	<b>251</b>	<b>252</b>	<b>253</b>	<b>254</b>	<b>255</b>					
Hex	fb	fc	fd	fe	ff					